

# THE **CLIL** RESOURCE PACK



Photocopiable and  
Interactive Whiteboard  
activities for Primary  
and Lower Secondary  
Teachers

By Margaret Grieveson  
and Wendy Superfine

Includes  
Interactive  
Whiteboard  
activities



PHOTOCOPIABLE

# Contents

	Page		Page
<b>Contents map</b>	4	<b>Unit 6 Physical Processes</b>	
<b>Introduction</b>	8	<b>1a</b> Earth, sun and moon	75
<b>Unit 1 The Human Body</b>		<b>1b</b> Day and night. What time is it?	74
<b>1a</b> Where are your organs?	12	<b>2a</b> The seasons	76
<b>1b</b> What do your organs do?	14	<b>2b</b> What do we wear in winter?	78
<b>2a</b> What can I do with my body?	16	<b>3a</b> The solar system	80
<b>2b</b> What do you look like?	18	<b>3b</b> The planets	82
<b>3a</b> How do you breathe?	20	<b>Unit 7 Forces and Motion</b>	
<b>3b</b> Measure your pulse	22	<b>1a</b> Moving toys: pushes and pulls	84
<b>Unit 2 Food and Health</b>		<b>1b</b> Pushing, pulling and slopes	86
<b>1a</b> How do you keep healthy?	24	<b>2a</b> Friction and movement	88
<b>1b</b> Diet. What did Little Red Hen eat?	26	<b>2b</b> Testing friction	90
<b>2a</b> What do you like to eat for lunch?	28	<b>3a</b> Magnetic force	92
<b>2b</b> What's in Tim's sandwich?	30	<b>3b</b> Working with magnets	94
<b>3a</b> Illnesses and medicine	32	<b>Unit 8 Light and Sound</b>	
<b>3b</b> A visit to the hospital	34	<b>1a</b> Light sources	96
<b>Unit 3 Living Things</b>		<b>1b</b> Light and shadows	98
<b>1a</b> Animals, plants and their habitats Where do they live?	36	<b>2a</b> Reflections	100
<b>1b</b> What can you find around here?	38	<b>2b</b> Everyday sounds and volume	102
<b>2a</b> The food chain	40	<b>3a</b> Light review	104
<b>2b</b> Micro-organisms	42	<b>3b</b> Sound: pitch	106
<b>3a</b> Animals in danger	44	<b>Unit 9 Environmental and Global Issues</b>	
<b>3b</b> Prehistoric animals: dinosaurs	46	<b>1a</b> Save – don't waste!	108
<b>Unit 4 Life Cycles</b>		<b>1b</b> Recycling	110
<b>1a</b> The life cycle of a bean plant	48	<b>2a</b> Personal communication links	112
<b>1b</b> The life cycles of plants	50	<b>2b</b> Global communications	114
<b>2a</b> The life cycle of a frog	52	<b>3a</b> Carbon footprint	116
<b>2b</b> The life cycle of butterflies and moths	54	<b>3b</b> Helping the Earth	118
<b>3a</b> Life cycles in changing habitats	56	<b>Unit 10 Weather and Water</b>	
<b>3b</b> What happens when a habitat is changed?	58	<b>1a</b> The water cycle	120
<b>Unit 5 Materials and Properties: Changing Materials</b>		<b>1b</b> Where does the water go? Rain and puddles	122
<b>1a</b> Can I change these shapes?	60	<b>2a</b> What's the weather like?	124
<b>1b</b> Fair tests for change	62	<b>2b</b> How does the weather affect us?	126
<b>2a</b> Will it dissolve in water?	64	<b>3a</b> The importance of water	128
<b>2b</b> A fair test: which substance dissolves more quickly?	66	<b>3b</b> How do boats float?	130
<b>3a</b> Separating mixtures by sieving and filtering	68	<b>Answers</b>	132
<b>3b</b> Reversible and irreversible changes	70	<b>Tapescript</b>	137

Level	Topic	Aims	Cross-curriculum links
<b>Unit 1 • The Human Body</b>			
1.1a	Where are your organs?	To Identify and locate some internal organs. To revise known parts of the body.	Literacy • Science Art & Design • Music
1.1b	What do your organs do?	To understand the functions of the main body organs.	Literacy • Science Art & Design • Music
1.2a	Muscles What can I do with my body?	To learn the location and main functions of the main muscles of the body. To revise known parts of the body.	Literacy • Science Art & Design
1.2b	What do you look like?	To revise facial features, colours and clothes. To describe eyes, hair, height, clothes, etc. To observe how people are the same/different.	Maths • Literacy Science • Art & Design
1.3a	How do you breathe?	To learn about the circulatory system. To revise organs of the body.	Science • Literacy Art & Design
1.3b	Measure your pulse	To understand the effects of exercise and rest on the pulse rate. To make predictions. To make a fair test. To record results.	Literacy • Science Maths • PE
<b>Unit 2 • Food and Health</b>			
2.1a	How do you keep healthy?	To recognise the importance of exercise and healthy diet to look after our body.	Literacy • Maths Art & Design
2.1b	Diet. What did Little Red Hen eat?	To understand the importance of a healthy diet. To understand the conditions needed for plants to grow. To revise main meals of the day and farm animals.	Literacy • Science
2.2a	What do you like to eat for lunch?	To understand and design a healthy diet. To understand the function of carbohydrates, proteins, fats and fibre.	Literacy • Science Maths • Art & Design
2.2b	What's in Tim's sandwich?	To identify the main meals of the day. To recognise the difference between and compare pupils' traditional meals and British food.	Literacy • Science Maths • Art & Design
2.3a	Illnesses and medicine	To be aware of health problems as a consequence of not looking after our bodies. To be aware of the importance of taking precautions to stop the spread of disease. To understand the use of medicines and drugs.	Literacy • Science PE • Art & Design
2.3b	A visit to the hospital	To learn about how accidents can happen, what to do when an accident has happened and how we can prevent accidents. To learn how to take responsibility for their own health and safety.	Literacy • Science Music • Drama
<b>Unit 3 • Living Things</b>			
3.1a	Animals, plants and their habitats Where do they live?	To establish links between different animals and plants and their habitats.	Science • PE Music • Art & Design
3.1b	What can you find around here?	To observe conditions in a local habitat and record the animals seen. To learn that animals are suited to their environments. To understand the difference between vertebrates and invertebrates.	Geography • Science Maths • Art & Design

Level	Topic	Aims	Cross-curriculum links
3.2a	The food chain	Order living things in simple food chains.	Literacy • Science Maths • Art & Design
3.2b	Micro-organisms	To identify micro-organisms as living things. To recognise their distinguishing features. To recognise their beneficial or harmful properties.	Literacy • Science Maths
3.3a	Animals in danger	To identify living things that are rare and the problems of survival.	Literacy • Science Maths • Geography
3.3b	Prehistoric animals: dinosaurs	To identify living things that are now extinct.	Literacy • History Maths • Art & Design

#### Unit 4 • Life Cycles

4.1a	The life cycle of a bean plant	To recognise and understand the life cycle of a bean plant.	PE • Literacy • Maths ICT • Art & Design
4.1b	The life cycles of plants	To use knowledge of one plant's life cycle to predict, recognise and understand the life cycle of other plants.	Literacy • Maths ICT • Art & Design
4.2a	The life cycle of a frog	To recognise and understand the stages in the life cycle of a frog.	Literacy • Music Art & Craft
4.2b	The life cycle of butterflies and moths	To recognise and understand the stages in the life cycle of butterflies and moths.	Literacy • Maths Art & Design • CTD
4.3a	Life cycles in changing habitats	Identify ways in which animal life cycles are adapted to changing habitats. Explore information texts.	Science • Literacy Geography • ICT Environmental Science
4.3b	What happens when a habitat is changed?	To recognise the ways life cycles are affected by environmental changes. To understand the difference between fact and opinion.	Science • Literacy Geography • ICT Environmental Science

#### Unit 5 • Materials and Properties: Changing Materials

5.1a	Can I change these shapes?	To understand that the shape of some objects can be changed because of the properties of their materials.	Literacy • Geography Maths • Art & Design
5.1b	Fair tests for change	To understand the meaning of a fair test. To be able to predict results of a fair test to change everyday materials by heating.	Literacy • Geography Art & Design • History ICT • Food Technology
5.2a	Will it dissolve in water?	To understand that some substances dissolve in water while others do not.	Literacy • History Geography • PSHE
5.2b	A fair test: which substance dissolves more quickly?	To be able to design and carry out a fair test. To find out if salt or sugar dissolves more quickly in cold water.	History • Literacy PSHE
5.3a	Separating mixtures by sieving and filtering	To apply knowledge of the characteristics of materials so as to be able to separate them from mixtures.	Geography Environmental Science
5.3b	Reversible and irreversible changes	To be able to use the knowledge of materials' different properties to identify reversible and irreversible changes.	Literacy • Science Food Technology

Level	Topic	Aims	Cross-curriculum links
<b>Unit 6 • Physical Processes</b>			
6.1a	Earth, sun and moon	To understand that the sun, the Earth and the moon are spherical. To understand that Earth orbits the sun and the moon orbits Earth.	Literacy • PE Maths • Art & Design
6.1b	Day and night What time is it?	To understand how day and night are related to the turning of the Earth on its axis. To raise awareness of time zones.	Literacy • PE Maths • Art & Design
6.2a	The seasons	To understand that the Earth tilts as it orbits the sun, giving us the seasons.	Literacy • PE Maths • Art & Design
6.2b	What do we wear in winter?	To understand how humans adapt to changes in climate and the weather.	Science • Maths Art & Design • Music
6.3a	The solar system	To identify the planets and main elements of the solar system.	Science • Maths Art & Design • PE
6.3b	The planets	To identify the planets and understand the differences between them.	Science • Maths Literacy
<b>Unit 7 • Forces and Motion</b>			
7.1a	Moving toys: pushes and pulls	To identify pushes and pulls as forces. To understand how toys can be moved by pushing or pulling.	Literacy • Drama History • Art & Design
7.1b	Pushing, pulling and slopes	To understand how slopes affect pushing and pulling.	Literacy • Drama History • Art & Design
7.2a	Friction and movement	To recognise the effect of friction on the movement of objects.	Literacy • History Geography • PE
7.2b	Testing friction	To investigate the effect of friction on the movement of objects.	Literacy • ICT PSHE
7.3a	Magnetic force	To understand that when magnets attract and repel, these are forces.	Geography • Maths Art & Design
7.3b	Working with magnets	To investigate magnetic forces.	Geography • Maths Art & Design
<b>Unit 8 • Light and Sound</b>			
8.1a	Light sources	To recognise natural and man-made light sources.	Literacy • Science Music • Art & Design
8.1b	Light and shadows	To understand that shadows appear when light is blocked.	Literacy • Science PSHE • Drama Art & Design
8.2a	Reflections	To investigate reflections in mirrors and shiny surfaces.	Literacy • Maths PSHE • Drama/PE Art & Design
8.2b	Everyday sounds and volume	To understand that sound is made when objects vibrate.	Literacy • Music Drama • PSHE

Level	Topic	Aims	Cross-curriculum links
8.3a	Light review	To revise and extend scientific vocabulary to describe the properties of light.	Literacy • Drama/PE Art & Design
8.3b	Sound: pitch	To investigate how pitch is related to size in a musical instrument.	Literacy • Maths Music • Art & Design

### Unit 9 • Environmental and Global Issues

9.1a	Save – don't waste!	To identify ways of conserving the Earth's resources.	Literacy • Science Geography • History Art & Design
9.1b	Recycling	To identify items that can be recycled.	Literacy • Science Geography • Maths Art & Design
9.2a	Personal communication links	To compare ways of communicating. To be able to select appropriate ways of communicating.	Literacy • Geography History • PSHE
9.2b	Global communications	To investigate different means of global communication and to identify facts and opinions in news reports.	Literacy • Geography Drama
9.3a	Carbon footprint	To identify ways in which individuals can make lifestyle changes which will reduce their impact on the Earth's resources.	Science • Geography ICT • Maths Art & Design
9.3b	Helping the Earth	To understand that everyone is part of a global community. To discuss how individual actions can affect the Earth.	Literacy • Science Geography • PSHE Citizenship

### Unit 10 • Weather and Water

10.1a	The water cycle	To be able to identify and sequence the key components of the water cycle.	Maths • Literacy Music
10.1b	Where does the water go? Rain and puddles	To understand the importance of water conservation. To understand the processes of evaporation and condensation.	Geography • Science Literacy • Art & Design
10.2a	What's the weather like?	To develop understanding of local and wider weather patterns. To understand that extreme weather is sometimes due to climate change.	Geography • Music Literacy • Art & Design
10.2b	How does the weather affect us?	To recognise different climatic zones. To understand how varying weather conditions affect or change the landscape and its inhabitants.	Geography • Maths Literacy • Art & Design
10.3a	The importance of water	To appreciate the importance of water in our daily lives. To recognise properties of water as a valuable element.	Maths • Music Art & Design • Science
10.3b	How do boats float?	To understand sinking and floating.	Maths • Literacy Art & Design • Science

# Introduction

## What is CLIL?

CLIL stands for Content and Language Integrated Learning. CLIL is the term used to describe the methodology of teaching a foreign language through another subject (content). In English language teaching, various forms of CLIL have previously been known as 'bilingual education', 'English across the curriculum' and 'content-based instruction'. Through this method, language is used to learn as well as to communicate and it is the subject matter which determines what language needs to be learnt. CLIL refers to teaching subjects such as Science, History, Geography, Art and Craft, Music, Physical Education and English Literature to students through a foreign language. This can be achieved either by the English teacher using cross-curricular content or by the subject teacher using English as the language of instruction. Both methods result in the simultaneous learning of content and of language. These basic principles of CLIL are used to teach cross-curricular topics in *The CLIL Resource Pack*.

Many countries have been teaching English at secondary school level through a CLIL curriculum very successfully for some time. It is now becoming increasingly popular to introduce the CLIL curriculum at primary level in situations where there are the resources and the motivation to learn English through other subjects.

## Why use CLIL in the primary and lower secondary EFL classroom?

- Children's educational experience is improved when the subject content is emphasised more than the language used.
- The language is learnt in context and therefore becomes more meaningful to children.
- CLIL is more motivating and provides a wider variety of stimuli for a broader range of learners.
- It gives learners greater exposure to the foreign language in a natural way.
- It does not require extra teaching time.

## Language content

The object of these materials is to present new topics using a cross-curricular approach while integrating the language and revising vocabulary and/or structures.

The language used in the topics in *The CLIL Resource Pack* is repeated in various ways and in different contexts throughout the units. Each topic has its own vocabulary, introduced as appropriate to the material in each lesson.

Each unit has a separate topic and they are graded according to the age and language level of the class, with Lessons 1a and 1b of each unit more suitable for elementary pupils and younger learners, Lessons 2a and 2b for intermediate level

and Lessons 3a and 3b for more advanced level and older pupils. Teachers can select a topic according to its suitability for their class. If a topic contains unfamiliar language which is difficult to explain in English, it may be necessary to translate the difficult language into the mother tongue. Each lesson plan contains a Warm up section which includes pre-teaching activities for any difficult vocabulary. Teachers must always feel free to translate such Warm up activities into the mother tongue in order to meet the needs of their class.

## Classroom language

For teachers who wish their pupils to use English when they are preparing and carrying out the activities, and using the photocopiable and IWB materials, it will be necessary to pre-teach the language used for instructions. Some phrases, such as the imperatives *Stand up* and *Sit down*, are covered within the topics; others which it may be useful to pre-teach include *Look at ...*, *Point to ...*, *Listen to ...*, *Cut out ...*, *Colour in ...*, *Draw this ...*, *Pick up ...*, *Glue this ...*, *Make a ...*, *Find a ...*, *Ask your friend*, as well as the classroom items listed in the Materials section, for example *scissors*, *crayons*, *glue*, *pencils*, *paper*, *cassette*, *puppets*, and so on.

## Classroom management

Young learners have certain characteristics which must be considered when planning the use of CLIL topics for EFL.

- They tend to be keen and enthusiastic learners, without the inhibitions which older learners sometimes bring to their schooling.
- They need physical movement and activity equally as much as stimulation for their thinking.
- They have a short attention span, so the lesson plans for the third level are probably more suitable for older primary and lower secondary learners as they require a longer attention span and a higher level of language.

For the purposes of this book we have assumed class sizes of sixteen pupils or more (where learners can work easily in pairs and groups of about four). Where classes are larger, teachers may wish to change some of the pair work activities into group activities and increase the group sizes to six or more depending on the activity type. Where there are smaller classes, then pupils can play some of the group games in pairs or as a class activity (i.e. one large group). For easier classroom management when using listening activities and the IWB, teachers could organise their class to sit in a circle on the floor in front of them.

When activities require pupils to work in pairs, it is helpful to vary the pairs from activity to activity. Pairs can be formed by asking pupils to work with the pupil on their right, on their left, behind them, in front of them, etc. With a small class, teachers can organise more random pairings, for example two pupils who have birthdays in the same month, or whose names both begin with the same letter.

## The topics and cross-curricular links

Ten CLIL topics are presented in *The CLIL Resource Pack*, as follows.

Unit 1 The Human Body

Unit 2 Food and Health

Unit 3 Living Things

Unit 4 Life Cycles

Unit 5 Materials and Properties: Changing Materials

Unit 6 Physical Processes

Unit 7 Forces and Motion

Unit 8 Light and Sound

Unit 9 Environmental and Global Issues

Unit 10 Weather and Water

Each topic in *The CLIL Resource Pack* is presented at three levels, with two lessons at each level: six 40/50-minute lessons per topic in all. The way lessons are used and presented will obviously vary from school to school and depend on the language level of the pupils, but the three levels have been designed to correspond approximately with the three levels of the curriculum for the majority of primary and lower secondary schools, that is:

- level 1: Primary (8-10 years)
- level 2: Primary/Lower Secondary (10-12 years)
- level 3: Lower Secondary (12+ years).

It is intended that the materials are adaptable and can be used in a variety of situations where the teacher feels they are suitable and can be adapted to fit their CLIL curriculum.

All activities have a strong emphasis on the four language skills of speaking, listening, reading and writing and at the same time are designed to teach cross-curricular subjects such as Science, History, Geography, Art and Craft, Music, Information and Communications Technology (ICT), Craft, Design and Technology (CDT), Personal, Social and Health Education (PSHE), Physical Education (PE) and English Literature to students through English as a foreign or second language. The Teacher's Notes for each lesson list the cross-curricular links that can be made.

## Lesson format in *The CLIL Resource Pack*

Each lesson in *The CLIL Resource Pack* consists of a double page spread, with a (left-hand) page of teacher's notes and a (right-hand) page of photocopiable activities.

### The Teacher's Notes

The Teacher's Notes set out the lesson plan and give suggestions for exploiting the material on the lesson's photocopiable activity page, including the listening activities.

### The lesson box

The teacher's notes begin with a lesson box containing a summary of the lesson aims, an outline of the language (new

vocabulary and structures) used in the lesson and a list of the extra materials required to conduct the lesson successfully. For some lessons, the list of extra materials includes pictures for the teacher to collect beforehand for use in the lesson. The internet and magazines are good resources for sourcing such material.

### Fact boxes

These provide a summary, and sometimes an extension, of the facts covered in the lesson. They can be used by the teacher as a teaching resource and by the pupils as a learning resource. Sometimes the Fact box is included as a part of the lesson plan.

### Warm up

The detailed lesson notes begin with ideas for the Warm up session which outlines relevant revision activities and pre-teaching activities for difficult vocabulary.

### Procedure

The Procedure section presents the main lesson notes and suggests ways of exploiting the Activity worksheets, the audio and IWB materials.

### Follow up

The Follow up activities are optional and include suggestions for adapting previous activities, and ideas for extending activities to reinforce learning as well as incorporating proposed further work on the topic.

The Follow up activities will vary in the time they require, and this in turn will depend on the ability of the class. It is therefore left to the teacher's discretion as to whether there is time to do one or more of the Follow up activities. As there is always flexibility in this approach to teaching younger learners, these activities can readily be adapted to suit the level of the pupils involved.

### Useful websites

The websites have been included as a tool for further research into the Unit topic and as a guide to finding further information and teaching materials. Not all listed websites will be available in every country but where accessible, they are intended for use as an internet extension for both teachers and pupils. In order to increase accessibility, it is possible to click on the "LINKS" section in the corresponding IWB activity and, if the classroom is internet enabled, to go straight to the website. Alternatively there is a full list of the websites provided in the "Web Resources" section of the IWB.

The search terms listed after the websites are intended to aid teachers in making their own internet search for further materials, most particularly when the listed sites are not available to them.

### Photocopiable activities

The photocopiable activities have been devised to be of interest to pupils of primary and lower secondary age and to provide fun in learning English across the curriculum. While there is a focus on speaking and listening skills initially, an increasing number of reading and writing activities are presented as the topics progress.

The sixty photocopiable pages contain a wide variety of activity types including worksheets for science activities, board games, card games (including Bingo, Snap, Memory, Sequencing and Four of a kind), colour dictation, surveys, tally charts, Venn diagrams, maps, crosswords, word searches, story books, models and things to make and do. A number of the activities require some preparation but, as children enjoy cutting and colouring, matching and sticking it is a simple task to involve them in the preparation. As well as providing a further means of practising classroom language (and the four language skills to varying degrees), it is a useful way to promote co-operation and class participation. However, when class time is limited, to save time, the bulk of the preparation can be done by the teacher.

If teachers intend their pupils to keep their worksheets, or to keep them as a record themselves, it is useful to ask the pupils to write their names on them. In the same way, when pupils are preparing card/board games, it is advisable for them to first stick their photocopy onto thin card to give it a longer life. These cards can then be stored in an envelope/box for use in another lesson if there is time or opportunity.

In addition to preparing their own materials to use in class, pupils will also produce a variety of artwork while carrying out the activities. Such artwork can be displayed on classroom walls and then bound together inside a cover with the name of the topic activity on it. Such personalised materials can then be displayed for open evenings or taken home to show to parents.

## Further course components in The CLIL Resource Pack

### Listening materials on the IWB CD-ROM

All the songs, chants, poems, dialogues and texts are recorded and can be found in the Resources section (under Audio Resources) of the IWB CD-ROM. These listening activities are provided as an example for the pupils of a native English-speaking voice, ideally to be used in addition (rather than as an alternative) to the model provided by the teacher. Where teachers feel sufficiently confident to do so, it is recommended that they read the material, sing the songs or say the chants to the class first and then play the model on the CD-ROM. To this end, tapescripts of the listening activities are provided at the back of the book. They are numbered T2, T3, T4, etc. and in those cases where the listening material is used as part of the activity, the number appears inside the Audio icon on the Activity sheet to enable easy access by teachers.

**Audio Texts:** It is also possible to either display or print out the audio texts by using the IWB CD-ROM. Go to the *Resources* section of the IWB CD-ROM, click on the track number and either use the 'print' control or the Audio script button.

### Songs and chants

Using songs and chants to enhance the teaching of topics through CLIL can help with:

- pronunciation
- grammar and vocabulary
- functions
- cognitive skills
- social skills
- conceptual areas
- knowledge of the subject and cultural background.

## Interactive whiteboard (IWB) activities on the CD-ROM

The teacher's notes for each lesson suggest a suitable point at which to introduce the interactive whiteboard activity for the topic.

### How to use the IWB

- 1 The cover page appears first.
- 2 The Main menu appears next.
- 3 Click on your chosen Unit.
- 4 Click on the Task(s) for your chosen Lesson.
- 5 You and your pupils can then follow the instructions for each activity.
- 6 Click on the blue check buttons (✓) to find out if you are correct or not.
- 7 Hover over the symbols at the bottom of the screen for an explanation of the tools available. Click a tool button to use it and when you have finished, click on the mouse button at the far left of the toolbar to exit.
- 8 Click on *Links* to show relevant websites for each Lesson.
- 9 Click on *URL* at the far right of the toolbar to type in and visit other websites.
- 10 On the Main menu, click on *Resources* to find:
  - **Audio Resources:** a list of all Audio Tracks on the CD-ROM. In addition, the Audio text for most of the Tracks is accessible by clicking on the Audio script button.
  - **Web Resources:** a list of all the websites for further research into the Unit topics (see notes on Useful websites on page 9 of this book).

For any questions or support in using the IWB CD-ROM, please visit *The CLIL Resource Pack* page on [www.deltapublishing.co.uk](http://www.deltapublishing.co.uk) or contact [info@deltapublishing.co.uk](mailto:info@deltapublishing.co.uk)

### What are the benefits of using an interactive whiteboard?

- It motivates and engages the pupils.
- It provides interactive materials which help to increase the attention span.
- It reduces preparation time.
- It provides more fun and games.
- It provides a visual presentation of the lessons.
- It usefully extends the material available in the activity pages.

## Games

The lesson teaching plans utilise a variety of games – these are not time fillers but are valuable activities which help the pupils to understand and use the vocabulary and language structures needed for the topic. All the games have a language objective and the pupils are expected to use as much English as possible while playing them.

Games also teach children about the importance of taking turns, of following rules, and of sharing, winning and losing – all of which are important skills to acquire at this age. The rules of some of the card games are not included in the teacher's notes for the specific page, so below is a bank of card games used in *The CLIL Resource Pack*.

### Bingo

#### Individual players

- 1 Give out the bingo cards with a grid of either 9 or 12 blank squares, or get the pupils to draw a bingo grid on paper.
- 2 Each pupil chooses 9 or 12 picture cards and places them face up on the bingo grid.
- 3 The teacher chooses a picture card and says the corresponding word out loud.
- 4 Pupils with a matching picture on their bingo grid turn the picture face down.
- 5 The teacher continues with the other words at random.
- 6 Pupils shout *Bingo!* when all their cards are face down.
- 7 The teacher checks their answers by asking them to turn their cards and say the words. If they are correct they win the game.

### Snap

#### Two or three players

- 1 The players share the cards between them, each mix up their own cards and put them into a pile face down on the table in front of them.
- 2 Pupil 1 turns over the first card, says the name of the object/animal and places it face up on the centre of the table.
- 3 The pupils take turns to do the same thing until there are two pictures the same, one after the other on the central pile.
- 4 The first pupil to shout *Snap!* or to place a hand on the top card picks up the pile of cards with the matching pair.
- 5 These cards are added to the bottom of the winner's pile and the game continues in the same way until one pupil has collected all the cards.
- 6 If three pupils are involved and one of them loses all their cards, the remaining two players continue until one of them wins all the cards.

### Memory

#### Pairs or groups

- 1 The cards are placed face down on the table and mixed up.
- 2 The pupils take turns to turn over two cards and say the name of the objects/animals. If they find two the same

they keep them. If there are two different pictures they are replaced on the table where they were found.

- 3 The pupil with the most matching pairs at the end of the game is the winner.

### Sequencing

#### Two players

- 1 The pupils sit back to back with all their cards on the table in front of them.
- 2 Pupil 1 arranges his/her cards in a certain order and then tells the order to Pupil 2.
- 3 Pupil 2 must put his/her cards in the same order.
- 4 If the pupils are familiar with the words, they can say them as quickly as possible to make it more difficult for Pupil 2.
- 5 Pupils now swap roles and repeat the game.

#### Four of a kind

#### Four players

- 1 Each player has a sheet of cards to cut out according to the teacher's notes.
- 2 All the cards are put together, mixed up and then shared out so that each pupil has the same number of cards. Pupils should hold their cards in their hands so that the others cannot see them.
- 3 The aim of the game is to collect sets of four pictures which are the same.
- 4 Firstly the pupils arrange their cards into sets. If they have four of a kind, they put them together on the table and say *I have four pictures of ...*
- 5 Now the pupils take turns to ask anyone in the group: *(Name), please have you got a picture of ...*. The named pupil either says *Yes* and hands the card over or *No* and the next pupil takes a turn.
- 6 The game continues until everyone has no cards left. The pupil with the most sets of four is the winner.

### Ten silly questions

#### A whole class activity, or for groups of two or four players

- 1 Display a selection of five or six items or pictures.
- 2 The players take turns to point to one of them and ask a 'silly question', for example, point to a house and ask *Is this a tree?*
- 3 The answer must be given in a sentence, for example *No this is not a tree, it's a house.*

We hope that teachers will find the materials presented in *The CLIL Resource Pack* an easy-to-follow, flexible and inspiring tool to facilitate their English teaching across the curriculum and motivate their pupils to successful and enjoyable learning.

# Where are your organs?

## Fact box

- Your brain is in your head.
- Your heart is in your chest.
- Your lungs are next to your heart.
- Your liver is under your lungs.
- Your stomach is under your liver.
- Your kidneys are above your intestines.
- Your intestines are under your stomach.
- Your bladder is under your intestines.

## Aims

- To identify and locate some internal organs.
- To revise known parts of the body.

## Language

- Questions: *Where is/are ...?*
- Instruction: *Touch your ....*
- Prepositions: *above, behind, in, next to, on, under*
- Vocabulary: *bladder, brain, chest, heart, intestine, kidneys, liver, lungs, stomach*

## Extra materials

- 1 copy of the Activity page per pupil, Audio Tracks 2 & 3, Audio texts, IWB
- scissors, glue sticks

## Warm up

- 1 Revise the body parts from Song 1 (Audio text for Track 2). Point to each body part and ask *What's this?*
- 2 Display Audio text for Track 2. Play Audio Track 2 and sing the song with the pupils, pointing to each body part.
- 3 Explain that the organs inside our body make it work.
- 4 Teach new body/organ words. Ask pupils to touch their chest and feel their heart beating, then to take a deep breath and feel their lungs moving.
- 5 Give out the Activity sheets. Point to each body organ, say its name and ask pupils to repeat.
- 6 Point to the part of the body where each organ is found and say the name. Pupils point and repeat.
- 7 Practise body and organ words. Play 'Simon says', touching body parts as you name them. Say *Simon says Touch your head/chest/stomach*, etc. and pupils touch the named part, too. Say *Touch your arm/heart*, etc. and pupils ignore the instruction.

## Procedure

- 1 Display Audio text for Track 3. Read Song 2 with pupils and ask them to point to each organ in their body.
- 2 Play Audio Track 3 and sing the song with the class, pointing to the organs again.
- 3 Now ask *Where is your ...?* Pupils respond *In/Next to/Under/Above my ...*. E.g. *Where is your brain? In my head.*
- 4 Display the IWB for the pupils to complete the activity.
- 5 Turn to the Activity sheet again. Tell the pupils to cut out the organs first and stick them in the correct place on the body and then to cut out the text labels and stick them in the correct boxes.

- 6 Go through the answers with the class. Ask pupils to swap papers and mark correct answers with a ✓ and incorrect ones with a ✗. (For a completed diagram, open Task 1 for Lesson 1.1b on the IWB, and click on the Show more button.)

## Follow up

- 1 Look at the crossword puzzle on the Activity page. Ask 8 pupils to read one clue each.
- 2 Tell the class to write their answers in the correct spaces.
- 3 Go through the answers with the class and ask pupils to swap papers and mark the answers as before.

## Useful websites

- [www.bbc.co.uk/schools/teachers/ks2bitesize/science/moving\\_growing.shtml](http://www.bbc.co.uk/schools/teachers/ks2bitesize/science/moving_growing.shtml)
- [www.tes.co.uk/ResourceDetail.aspx?storyCode=3004907](http://www.tes.co.uk/ResourceDetail.aspx?storyCode=3004907)  
Free registration. Under *Major Body Organs* click on the Word documents for visuals

**Search terms:** human body, organs

## Cross curricular links

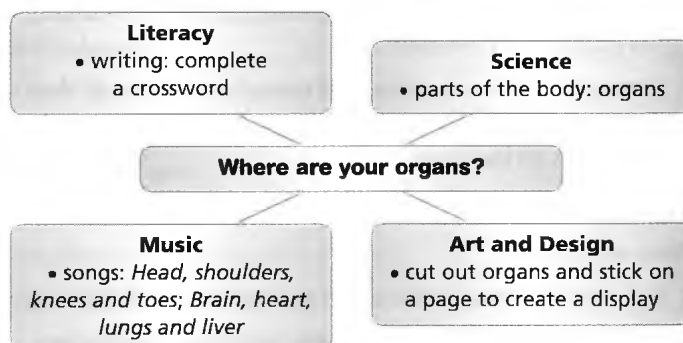

# Where are your organs?

## 1 Cut and stick

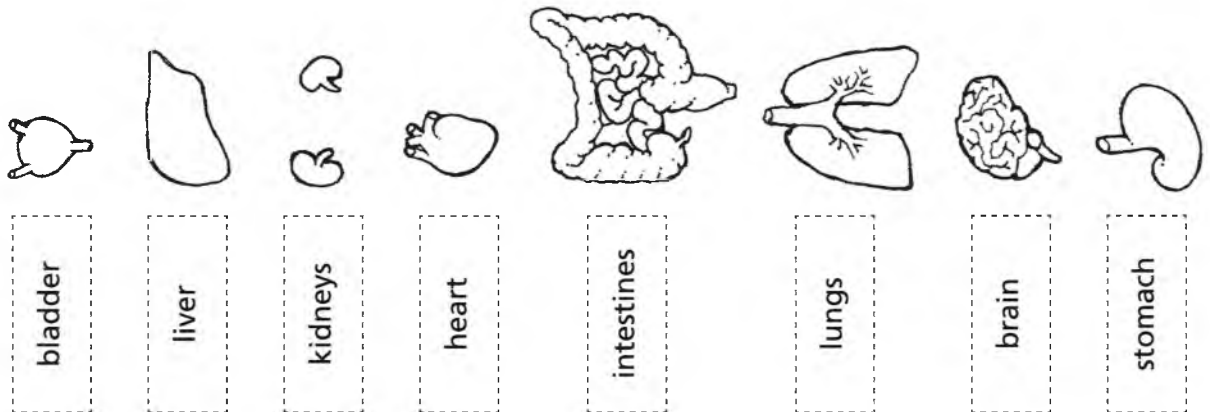

## 2 Complete the crossword

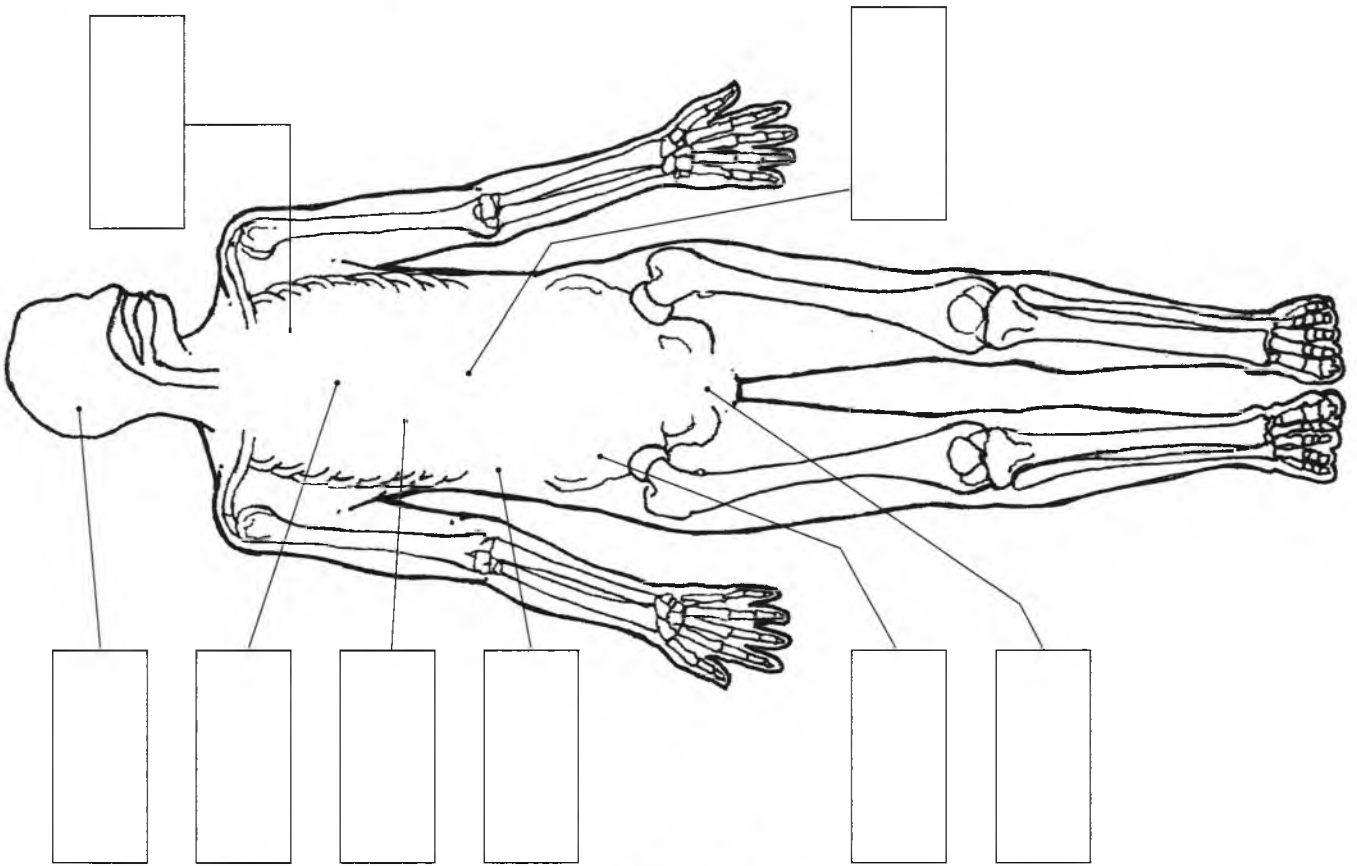
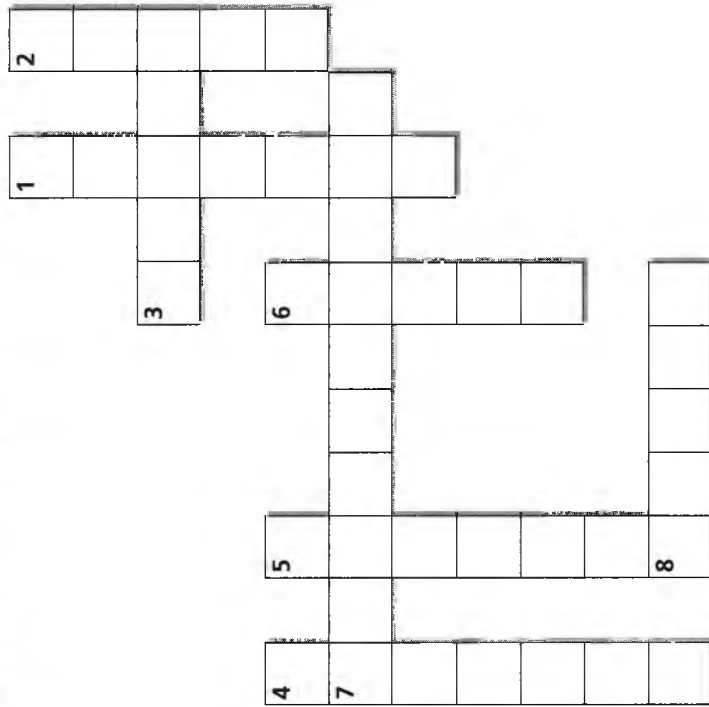

### Clues:

#### Across

- 3 It's in your head.
- 7 It's under your stomach.
- 8 It's in your chest.

#### Down

- 1 It's under your intestines.
- 2 They are next to your heart.
- 4 They are above your intestines.
- 5 It's under your liver.
- 6 It's under your lungs.

# What do your organs do?

## Fact box

- Your heart pumps blood.
- Your brain sends messages to the muscles.
- Your lungs breathe in air and oxygen.
- Your liver processes chemicals.
- Your stomach processes and stores food.
- Your kidneys process water.
- Your bladder stores water.
- Your intestines process food.

## Aim

- To understand the functions of the main body organs.

## Language

- Questions: *What do/does your ... do?*
- Verbs: *breathe, hold, move, process, pump, send, store, support, think*
- Vocabulary: *blood, chemicals, oxygen*

## Extra materials

- 1 copy of the Activity page per pupil, Audio Track 3 from Lesson 1.1a, Audio Track 4, Audio text Track 4, IWB

## Warm up

- 1 Play Audio Track 3 from Lesson 1.1a and sing Song 2 again.
- 2 Ask pupils to look at the completed body from Lesson 1 and to point and say what each organ is called.
- 3 Revise names of the body organs by repeating the questions in Lesson 1 Procedure 3.

## Procedure

- 1 Give out the Activity sheets. Point to the organs at random and ask each pupil to say then spell its name.
- 2 Ask pupils to write correct organ names in the spaces.
- 3 Go through the answers with the class and ask pupils to swap sheets and mark the correct answers with a ✓ and the incorrect ones with a ✗.
- 4 Talk about the functions of the organs. Ask *What does your heart do?* Accept any correct answers then say *It pumps the blood* and ask the class to repeat the answer. Repeat the procedure for the other organs.
- 5 Display the IWB. This activity can be used alone, or followed by 6 and 7 below to give further practice and confidence in using the new language and knowledge.
- 6 Write these jumbled questions and answers on the board. Ask each pupil to read a question or answer.

- |                              |   |
|------------------------------|---|
| 1 What does your heart do?   | d It processes and stores food.             |
| 2 What does your brain do?   | e They process water.                       |
| 3 What does your liver do?   | b It sends messages to the muscles.         |
| 4 What does your stomach do? | g They breathe oxygen.                      |
| 5 What do your kidneys do?   | f It stores water until I go to the toilet. |
| 6 What does your bladder do? | a It pumps the blood.                       |
| 7 What do your lungs do?     | h They process the food.                    |

- 8 What do your intestines do?      c It processes chemicals.

- 7 Tell the pupils to match each question with the correct answer. Listen to Audio Track 4 (see Audio text) to check the answers.

## Follow up

- 1 Use the Activity sheet. Put the class into pairs, A and B. A cuts out cards with organs and B cuts out cards with organ functions.
- 2 Tell them to match each organ to the work it does to make 7 pairs of cards. Check answers with the class.
- 3 Tell pupil pairs to put the cards face down, mix them up and play the Memory game (see Introduction).

## Useful websites

- [www.bbc.co.uk/schools/scienceclips/ages/9\\_10/keeping\\_healthy.shtml](http://www.bbc.co.uk/schools/scienceclips/ages/9_10/keeping_healthy.shtml)
- [www.tes.co.uk/teaching-resource/The-Human-Body-Project-6014192](http://www.tes.co.uk/teaching-resource/The-Human-Body-Project-6014192)  
Under *The Human Body Project*, click on PDF and DOC for grades 5-6 and Lower Secondary resources





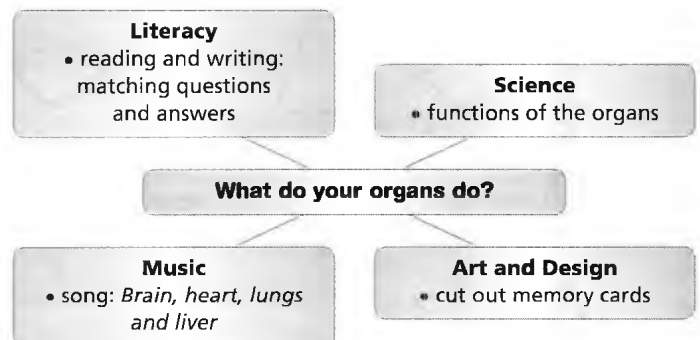

**Search terms:** human body, organs, functions

## Cross curricular links

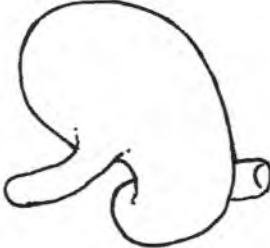

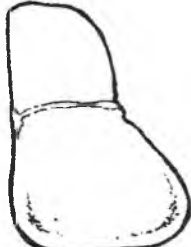
# What do your organs do?

T4 Write the names of the organs

						
_____	_____	_____	_____	_____	_____	_____

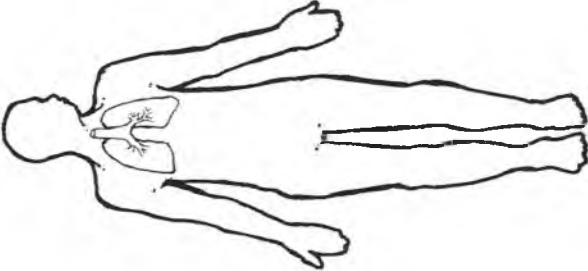
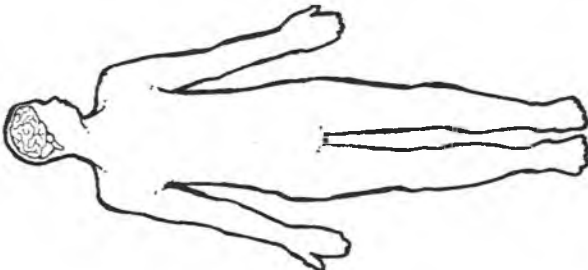
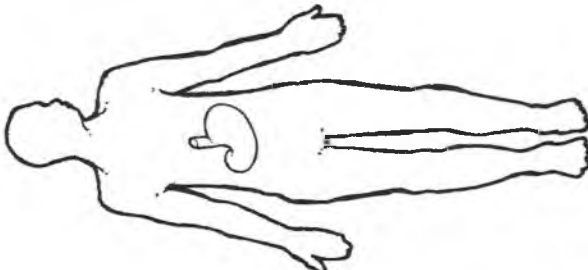
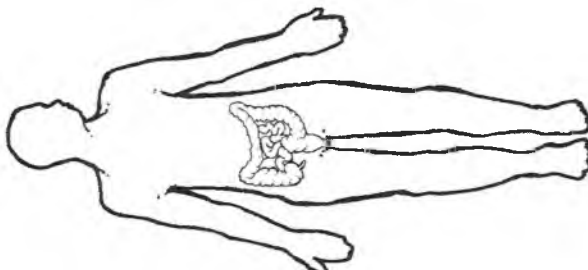
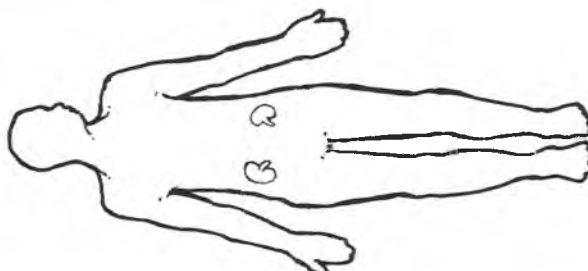
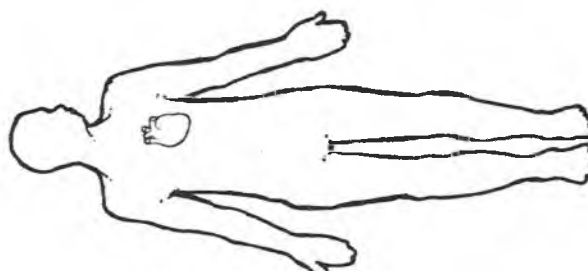
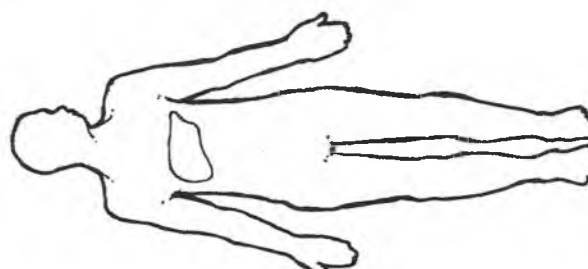
						
They breathe in oxygen.	It sends messages to the muscles.	It processes and stores food.	They process the food.	They process water.	It pumps the blood.	It processes chemicals.

# What can I do with my body?

## Fact box

When you ...	you use your ....
run	legs, arms, eyes, body.
sit and read	arms, head, eyes, body.
watch TV	eyes, head, body.
swim	arms, legs, eyes, body.
cycle	arms, legs, eyes, ears, body.
draw	arms, hands, eyes, head, body.

- The muscles in your arms are called *biceps* and *triceps*.

## Aims

- To learn the location and main functions of the main muscles of the body.
- To revise known parts of the body.

## Language

- Questions: *What can I do? What's this?*
- Vocabulary: *biceps, muscles, triceps*
- Verbs: *cycle, draw a picture, read a book, run, sit, swim, watch TV*

## Extra materials

- 1 copy of the Activity page per pupil, IWB
- scissors, 8 split pins & 1 envelope per pupil, book: *Funnybones*, by Alan Ahlberg, Puffin, 2010



split pin

## Warm up

- 1 Ask the class which part of their body they use when they run, sit down, stand up, wave, etc.
- 2 Explain that when they move, their brain is sending a message to the muscles in their body to move.
- 3 Ask pupils to stand up and mime these actions: running, sitting in a chair reading a book, watching TV, swimming, cycling, drawing a picture.

## Procedure

- 1 Give out the Activity sheets and ask the pupils to look at activity 1.
- 2 Say *Look at these pictures. Ask Which parts of your body do you use for each activity? Choose from your head, legs, arms, hands, eyes, ears and your whole body.* Put the pupils into pairs, A and B. Tell them to take turns to ask and answer: *Which part of your body do you use for number 1/2/3/4/5/6?*
- 3 Tell them to write the names of the body parts used for each activity in the space next to the picture.
- 4 Ask some pupils to share and check their answers with the class.
- 5 Tell pupils to swap their papers and mark the correct answers with a ✓ and the incorrect ones with a ✗.
- 6 Display the IWB. This activity checks comprehension and reinforces the new language.

## Follow up

- 1 Show the pupils how to clench a fist and feel the muscles in their arm. Teach the names of the arm muscles: *biceps* and *triceps*. Say the words and ask the pupils to repeat. Write the words on the board.
- 2 Tell the pupils to write the words in the boxes to label the arm muscles in Activity 2 on the Activity page.
- 3 Explain that the pupils are going to make a body. Ask them to cut out the body parts very carefully.

- 4 Show them how to overlap the arms and legs at the joints and then join them together with a split pin. (*Tips!* Safety first: make the hole with a pencil point. Reinforce the back of the hole with sticky tape.)
- 5 Now ask them to find out what movements their body can make.
- 6 Tell the pupils to put their paper body safely in an envelope so they can use it again.
- 7 Ask *What other things can we do with our bodies?* (E.g. dance, listen to the radio and CDs, sleep, lie down, climb, eat, etc.) Mime the actions with the class and ask which body parts they use for each one.
- 8 If there is time, read the story *Funny Bones*, by Alan Ahlberg.

## Useful websites

- [www.climatechangematters.net.au/LOTS/Bio/sub/muscles/muscles.htm](http://www.climatechangematters.net.au/LOTS/Bio/sub/muscles/muscles.htm)
- [www.crickweb.co.uk/ks2science.html](http://www.crickweb.co.uk/ks2science.html)  
Click on *Moving and growing*





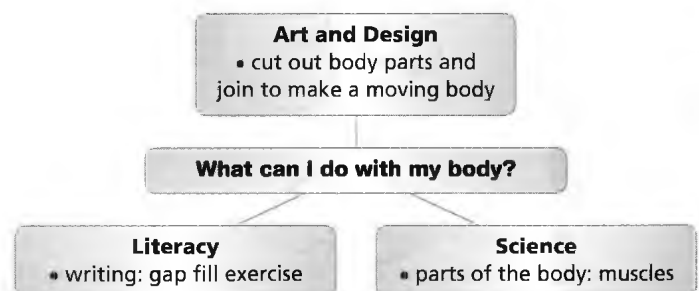

**Search terms:** muscles, moving arms

## Cross curricular links



# What can I do with my body?

## 1 Write the body parts

I can ...	I use my ...
<b>1</b>  run.	_____ _____ _____
<b>2</b>  read a book.	_____ _____ _____
<b>3</b>  watch TV.	_____ _____ _____
<b>4</b>  swim.	_____ _____ _____
<b>5</b>  ride a bike.	_____ _____ _____
<b>6</b>  draw a picture.	_____ _____ _____

## 2 Make me move

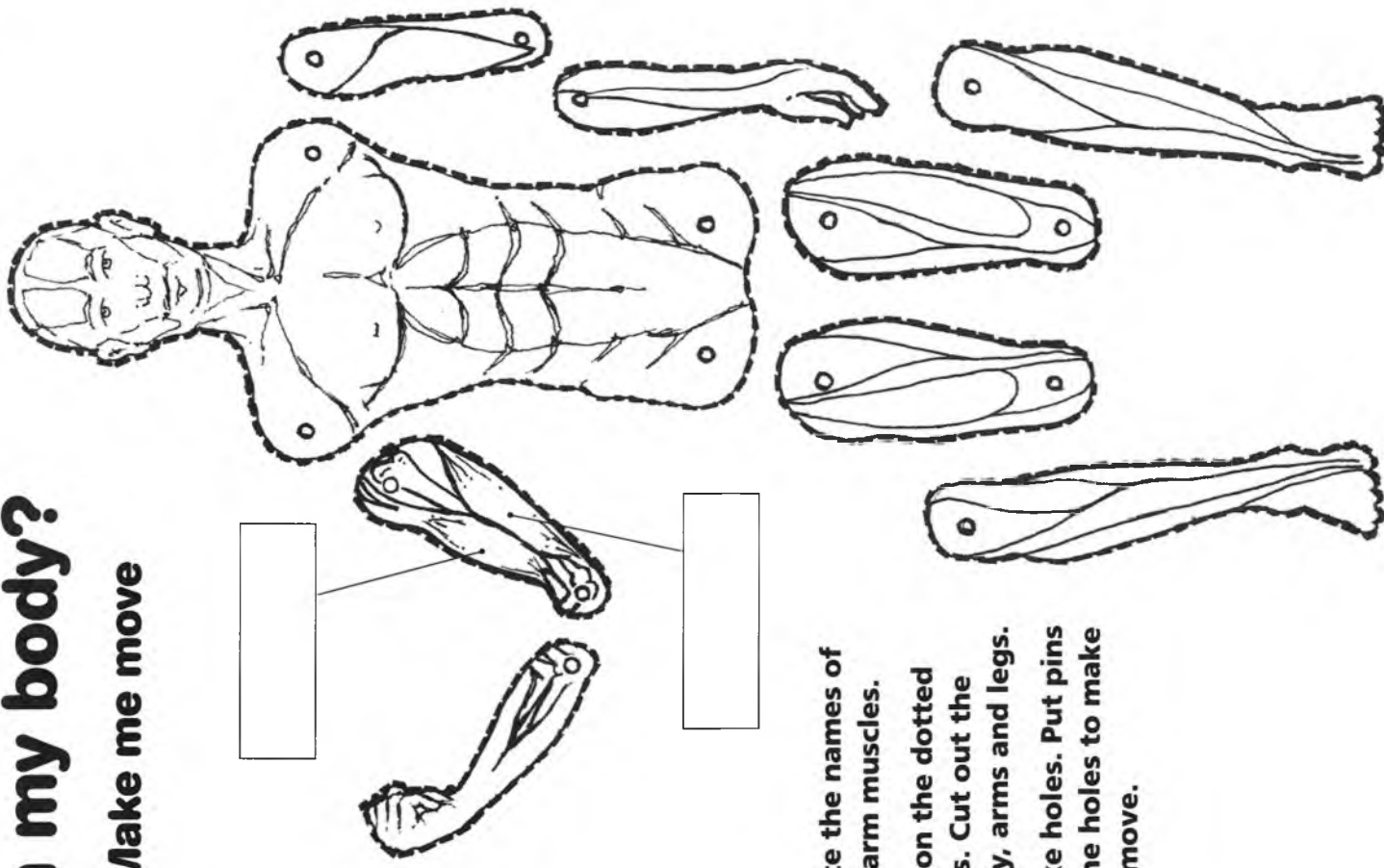

Write the names of the arm muscles.  
 Cut on the dotted lines. Cut out the body, arms and legs.  
 Make holes. Put pins in the holes to make me move.

# What do you look like?

## Fact box

- There are 5 hair colours: black, brown, blonde, ginger, grey.
- There are 4 eye colours: brown, blue, green, grey.
- Most people are different from each other.
- If a mother has 2 babies born at the same time, they are called *twins*. If they are exactly the same, they are *identical twins*.

## Aims

- To revise facial features, colours and clothes.
- To describe eyes, hair, height, clothes, etc.
- To observe how people are the same/different.

## Language

- Questions: *What colour ... have I/you got? What colour ... has he/she got? Is it long or short? Am I tall or short? Is he/she tall or short? What have they got that is the same/different?*
- Adjectives: *different, long, short, tall, the same*
- Vocabulary: *bag, black, blonde, brown, cap, ears, eyes, green, hair, identical twins, mouth, nose, purple, red, shoes, sweater, trousers, twins, yellow*

## Extra materials

- 1 copy of the Activity page per pupil, Audio Track 5, Audio text, IWB
- coloured pencils

## Warm up

- 1 Point to your eyes and ask *What colour eyes have I got?* Model the answer *I've got ... eyes*. Choose a pupil. Ask *What colour eyes has he/she got?* Model the answer *He's/She's got ... eyes*.
- 2 Repeat step 1, asking about your hair colour. Then, ask *Is it long or short?* Indicate the meaning by raising/lowering your hand. Model the answer *It's ....* Choose a pupil and ask *What colour hair has he/she got? Is it long or short?* Model the answer *He's/She's got ... hair. It's ....*
- 3 Stand up and ask *Am I tall or short?* Indicate the meaning of the adjectives by raising/lowering your hand. Model the answer *I'm ....* Choose a pupil and ask *Is he tall or short?* Model the answer *He's/She's ....*

## Procedure

- 1 Invite 2 pupils to the front. Ask about them as above.
- 2 Choose a feature that is the same for both pupils, e.g. hair colour, and ask *What have they got that is the same?* Model the answer, e.g. *Blonde hair*. Repeat with other features and different pairs of pupils.
- 3 Choose a feature that is different, e.g. eye colour and ask *What have they got that is different?* Model the answer, e.g. *He's got blue eyes. He's got brown eyes*. Repeat with other features and different pupils.
- 4 Give out the Activity sheet. Teach *twins* and *identical twins*. Tell pupils to look at the two boys in activity 1. Ask *Are these boys identical twins? Why/Why not?* (No, one is tall; the other is short.)
- 5 Play Audio Track 5 (see Audio text). Tell pupils to listen carefully and colour the picture of Joe.
- 6 Display the IWB for pupils to complete the activity. Ask the class about Joe: *What colour ... has Joe got?* (brown hair, blue eyes, green cap, red sweater, black trousers, brown shoes, purple bag)

- 7 Tell the pupils to colour Jim on the Activity sheet using mostly different colours and to complete the labels with the colour words.
- 8 Put the pupils into pairs to ask/answer about Joe and Jim using *What colour ... has ... got? What colour is/are his ...? Is his hair long or short? Is he tall or short? What have they got that is the same/different?*
- 9 Pupils can also compare their pictures of Jim in the same way.

## Follow up

- 1 Put the pupils into groups of 6. Tell them to ask each other *What colour hair/eyes have you got?*
- 2 Show them how to complete the bar graph for their hair survey and the pie chart for their eye survey.
- 3 Ask the groups to share their findings with the class. Make bar and pie charts for the whole class.

## Useful website

- [www.primaryresources.co.uk/art/portraits.htm](http://www.primaryresources.co.uk/art/portraits.htm)

**Search terms:** human body, our faces

## Cross curricular links

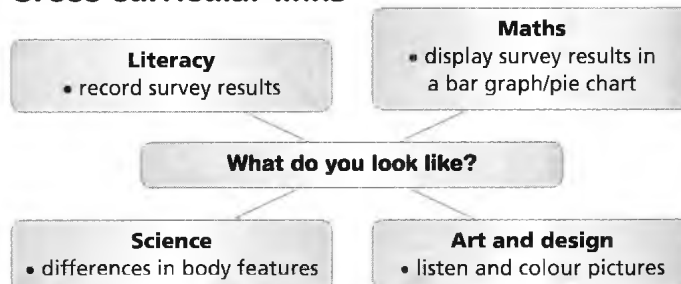

# What do you look like?

## 1 T5 My friends, Joe and Jim

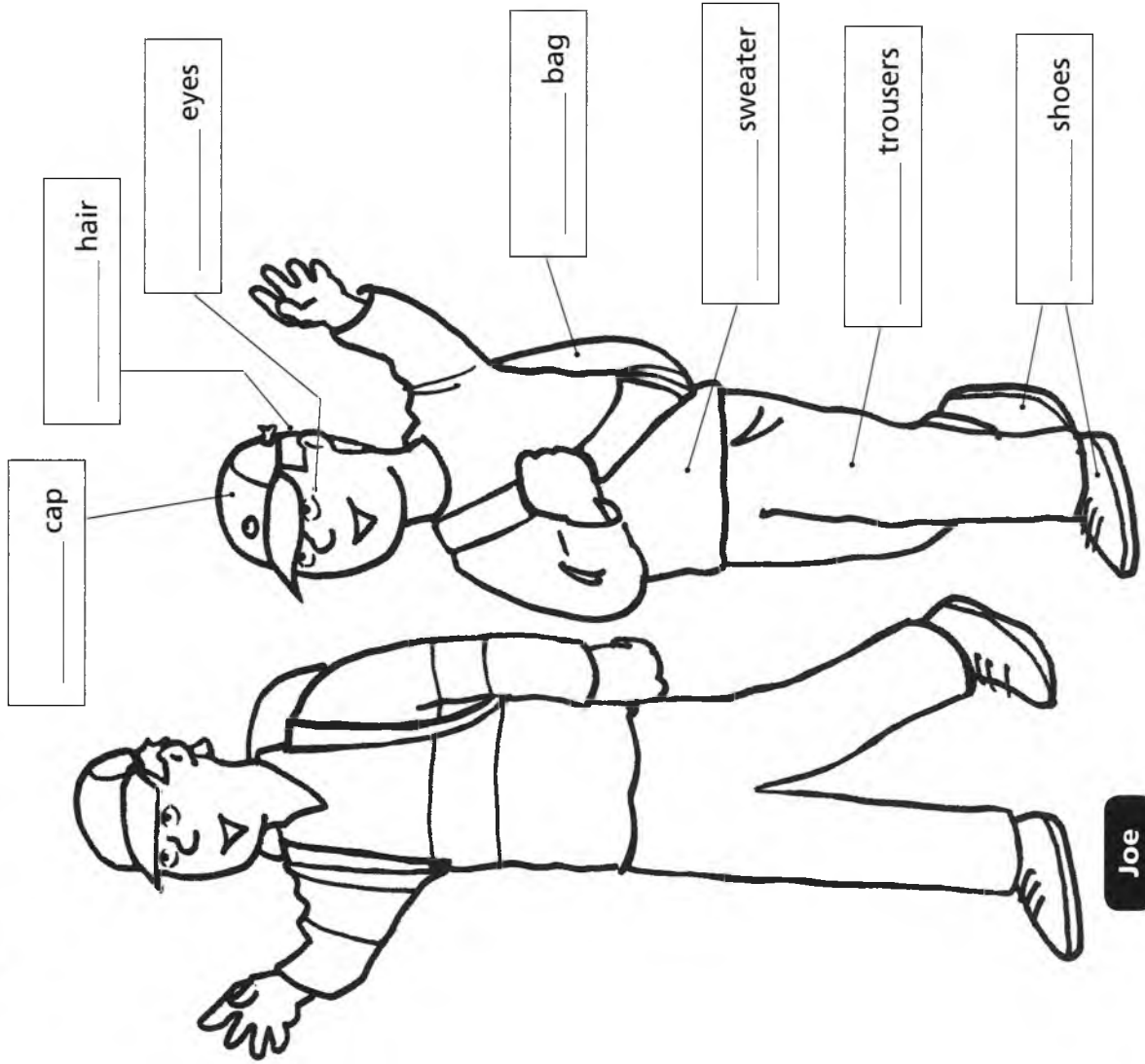

Joe

Jim

## 2a What colour hair have you got?

6							
5							
4							
3							
2							
1							

black brown blonde ginger grey

## 2b What colour eyes have you got?

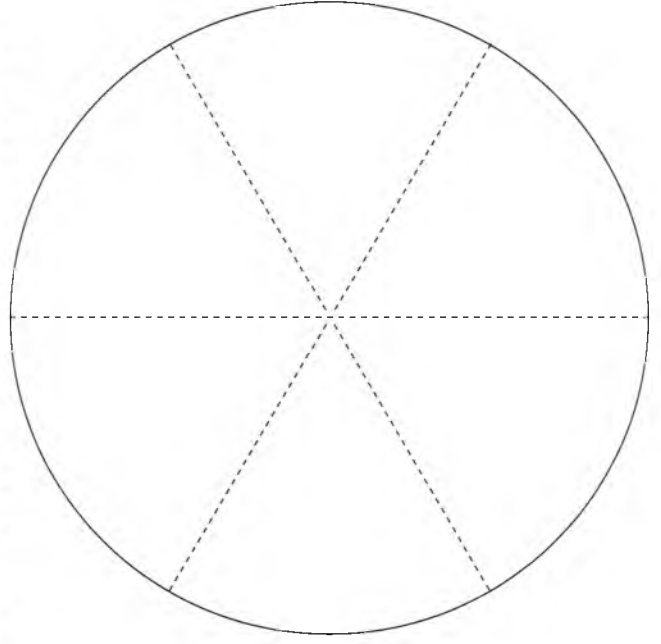

# How do you breathe?

## Fact box

### The circulatory system

- This is the heart and all the tubes that carry blood around the body in 2 circles.

### How does it work?

- The heart pumps blood to the lungs.
- The blood takes in oxygen and returns to the heart.
- The heart pumps the oxygenated blood to the rest of the body and then back to the heart.
- Most arteries carry blood away from the heart.
- Most veins carry blood to the heart.

## Aims

- To learn about the circulatory system.
- To revise organs of the body.

## Language

- Directions: *from, to*
- Verbs: *carry, exchange, protect, pump, take, travel*
- Vocabulary: *artery, blood, bone, carbon dioxide, false, gas, heart, lungs, oxygen, pulse, pulse rate, rest of the body, true, vein*

## Extra materials

- 1 copy of the Activity page per pupil, IWB
- Red and blue coloured pencils

## Warm up

- 1 Revise body vocabulary from Lessons 1.1a and 1.1b.
- 2 On the IWB, click on the Show more button to display a diagram of the circulatory system. Read the text in the Fact box above to the class and use the diagram to illustrate the information.
- 3 Ask *What does your heart do? What do your lungs do?*
- 4 Tell the pupils to put a hand on their chest and feel their heart beating.
- 5 Tell them to take a deep breath and feel their lungs moving.
- 6 Now tell them to stand up and run on the spot for a minute.
- 7 Ask *Can you feel your heart beating? Does it feel faster or slower?*

## Procedure

- 1 Give out the Activity sheets and teach/revise *true* and *false*.
- 2 Read through the sentences in activity 1 with the pupils. Tell them to decide if each sentence is true or false and to write *T* by the true sentences and *F* by the false ones.
- 3 Ask pupils to correct the false sentences.
- 4 Check the answers to activity 1 by displaying the IWB and completing the activity with the class.

## Follow up

- 1 Look on the IWB at the diagram of the circulatory system again and discuss how the blood travelling from the lungs contains oxygen and the blood travelling to the lungs contains carbon dioxide. Close the IWB.

- 2 Tell the pupils to look at activity 2 on the Activity sheet and read the labels. Read the colouring instructions with the class and make sure they understand them. Explain that the right side of the 'rest of the body' will be red and the left side will be blue. Tell the pupils to colour their diagrams.
- 3 Use the IWB diagram of the circulatory system for pupils to check their own.

## Useful websites

- [www.bbc.co.uk/schools/ks2bitesize/science/living\\_things/keeping\\_healthy/play.shtml](http://www.bbc.co.uk/schools/ks2bitesize/science/living_things/keeping_healthy/play.shtml)  
Click *OK*
- [www.primaryresources.co.uk/science/powerpoint/scienceheart.ppt](http://www.primaryresources.co.uk/science/powerpoint/scienceheart.ppt)  
Scroll down to view 15 slides
- [www.primaryresources.co.uk/science/science2b.htm#circulation](http://www.primaryresources.co.uk/science/science2b.htm#circulation)  
Click on the resources listed under *Circulation*
- [www.collaborativelearning.org/bloodcirculation.pdf](http://www.collaborativelearning.org/bloodcirculation.pdf)  
Photocopiable games

**Search terms:** heart, lungs, circulation

## Cross curricular links

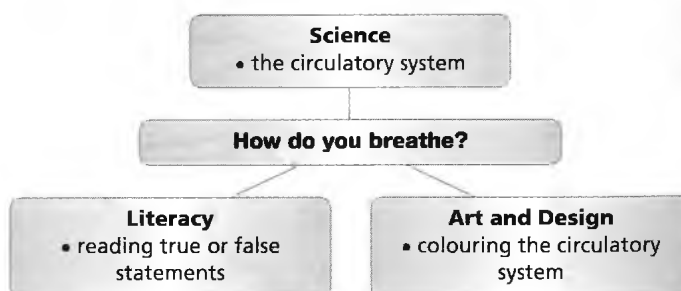

# How do you breathe?

## 1 Are these sentences true or false?

Write T or F.

- 1 Your heart pumps blood around your body. \_\_\_\_\_
- 2 Your blood carries carbon dioxide to all parts of your body. \_\_\_\_\_
- 3 Your lungs exchange gases. \_\_\_\_\_
- 4 Blood travels around your body. \_\_\_\_\_
- 5 The ribs are the bones that protect the heart and lungs. \_\_\_\_\_
- 6 Exercise and healthy eating are good for your heart. \_\_\_\_\_
- 7 Children have a slower pulse rate than adults. \_\_\_\_\_

Correct the false sentences.

---

---

---

---

---

---

---

---

## 2 Your circulatory system

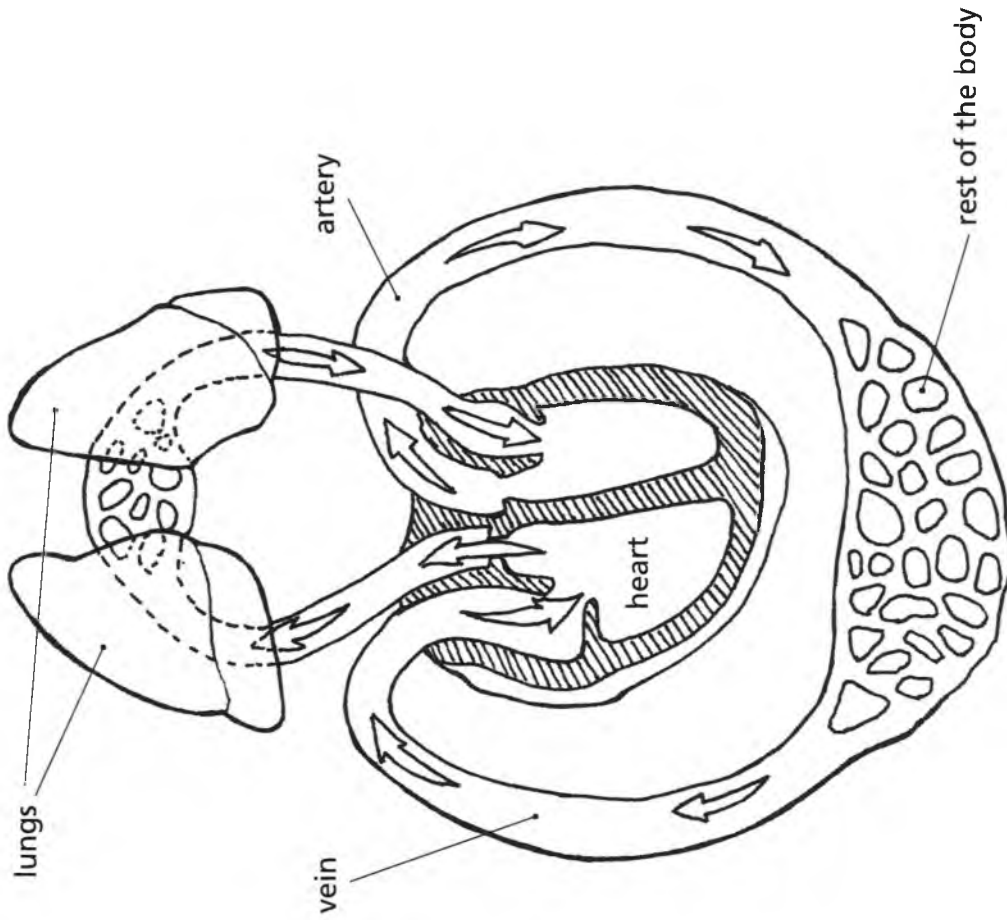

Colour the top of the lungs and the right side of the heart red.

Colour the blood going away from the heart red.

Colour the blood going to the heart blue.

Colour the left side of the heart and the bottom of the lungs blue.

Lesson  
3b

## Measure your pulse

## Fact box

- Your pulse is the beat your heart makes as it pumps blood around your body.
- Your heart beats faster or slower depending on what you are doing.
- You can find out how fast your heart is beating. Put the first 2 fingers of your left hand on the inside of your right wrist or on your neck below your chin. Feel the pulse and count the number of beats your heart makes in 1 minute.

## Aims

- To understand the effects of exercise and rest on the pulse rate.
- To make predictions.
- To make a fair test.
- To record results.

## Language

- Verbs: *beat, measure*
- Vocabulary: *conclusion, energy, exercise, prediction, pulse, rest*

## Extra materials

- 1 copy of the Activity page per pupil, IWB
- a large clock with a second hand

## Warm up

- 1 Briefly revise the circulatory system from Lesson 1.3a.
- 2 Discuss why we do exercise. Ask the pupils to write down activities that use energy. Invite pupils to share their ideas with the class. Ask *How do you feel after you have done some exercise? What happens to your body when you exercise? What happens to your pulse rate?*

## Procedure

- 1 Write the text from the Fact box on the board. Read the facts with the class.
- 2 Ask *What is pulse rate? How can we measure our pulse rate?* Put the pupils into pairs, A and B. Explain that they are going to measure and record their partner's pulse rate at rest and then after different exercise.
- 3 Give out the Activity sheets. Look at activity 1 and tell pupils to write *sitting* in the first box.
- 4 Make sure the clock is visible. Demonstrate how to count a pulse for a minute using the second hand.
- 5 Tell the pupils to take turns to measure their partner's pulse while their partner is sitting down. Each pupil records his/her own pulse on the table.
- 6 Ask the pupils to write *running* in the box below *sitting*. Tell them to predict if their pulse rate will go up or down after running, and to write 2 in the time box.
- 7 Tell pupil B to go outside and run around the playground for 2 minutes.
- 8 Tell pupil A to measure pupil B's pulse as soon as pupil B returns. Repeat to find pupil A's pulse after running. Each pupil records his/her own pulse on the table.
- 9 Tell the pupils to choose two other activities and repeat steps 6 to 8 above for each of them.
- 10 Ask several pupils *Which is your fastest pulse rate? Which is your slowest pulse rate?*
- 11 Tell them to fill in the Conclusion on the Activity sheet. Discuss the answers with the class.

- 12 Read first the question in activity 2 then display IWB Task 1 and complete the activity with the class.
- 13 Tell the pupils to complete the table on the Activity sheet and then discuss the answers with the class.

## Follow up

- 1 Look at activity 3. Ask 8 pupils each to read a word from the list. After each word, ask the class to spell out the letters, e.g. *v, e, i, n*.
- 2 Tell them to look in all directions (like the arrows) to find and mark the words.
- 3 Display IWB Task 2 and complete the activity with the class for pupils to check their answers.

## Useful websites

- [www.primaryresources.co.uk/science/pdfs/pulse\\_rate\\_LF.pdf](http://www.primaryresources.co.uk/science/pdfs/pulse_rate_LF.pdf)
- [www.bbc.co.uk/schools/ks2bitesize/science/living\\_things/keeping\\_healthy/play.shtml](http://www.bbc.co.uk/schools/ks2bitesize/science/living_things/keeping_healthy/play.shtml)  
Click OK.
- [kidshealth.org/kid](http://kidshealth.org/kid)  
Click on *How the Body Works*, then on the different organs. For Lower Secondary

**Search terms:** pulse rate, my body, exercise

## Cross curricular links

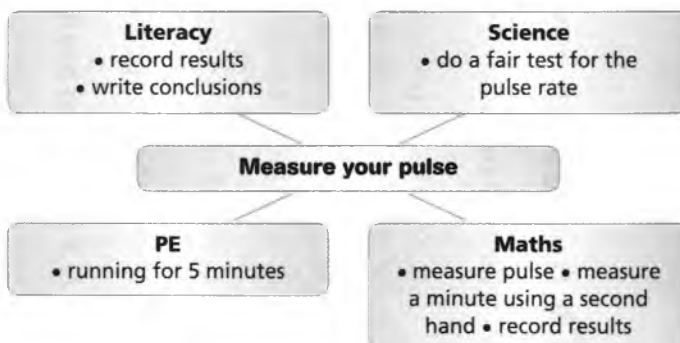

# Measure your pulse

## 1 My pulse rate

Complete the table, then the conclusion.

Exercise/Activity	Prediction (up/down)	Time (minutes)	Pulse rate		Did it go up or down?	Was your prediction right?
			before	after		

### Conclusion

When I exercise, my pulse rate goes \_\_\_\_\_. When I rest it goes \_\_\_\_\_.

My fastest pulse rate was \_\_\_\_\_ per minute. The activity was \_\_\_\_\_.





My slowest pulse rate was \_\_\_\_\_ per minute. The activity was \_\_\_\_\_.

When I exercise, my heart beats faster because my body and muscles need more \_\_\_\_\_.

## 2 Joe's heart beat

Which activity will make Joe's heart beat the fastest?

Write the correct pulse rate for each activity.

				beats per minute		
						132
running	sitting	walking	sleeping	67	78	98
_____	_____	_____	_____			

## 3 Find these words:

heart

lungs

vein

artery

body

oxygen

carbon dioxide

pulse

Look:

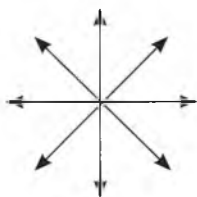

E D I X O I D N O B R A C  
 R M B D L K R M E O R T L  
 T B F A Z P R J X S K X D  
 Y T Z L R K J Y L Z L F L  
 J P T L W T G F T Z K U Q  
 H C R F P E E R J P V K P  
 N L F J N W H R K J T K S  
 R T D C T T J V Y N K G N  
 Y X J X H T W B M C N W H  
 C V E I N R M O Y U G W K  
 R X Y Q R A N D L Z M K G  
 Z P Q L K E B Y Z M T M Y  
 Z L F C Y H Y L M H N B M

Lesson  
1a

# How do you keep healthy?

**Fact box**

To keep healthy, we must

- eat healthy foods and
- exercise each day.

**Aims**

- To recognise the importance of exercise and a healthy diet to look after our body.

**Language**

- Vocabulary: *eat well, exercise, healthy, junk food, less healthy, rest, unhealthy*

**Extra materials**

- 1 copy of the Activity page per pupil, IWB
- pictures of/actual healthy foods and drinks, e.g. vegetables, fruit, salad, eggs, meat, bread, pasta, rice, cheese, water, fruit juice, milk, honey; pictures of/actual less healthy foods and drinks, e.g. chips, cakes, biscuits, sweets, chocolate, jam, ice cream, fizzy drinks; pictures of people doing physical exercise, e.g. running, swimming, gymnastics, football, tennis, etc.
- for each group of pupils: poster paper, pictures (as above), scissors, glue sticks, coloured pencils

**Warm up**

- 1 Display and name the healthy foods/pictures of healthy foods.
- 2 Display and name the less healthy foods/pictures of less healthy foods.
- 3 Teach *healthy, less healthy* and *unhealthy*. Talk about what is healthy food and what is less healthy food.
- 4 Display the IWB for the pupils to complete the exercise.
- 5 Ask the pupils to say what exercise they do each day.

**Procedure**

- 1 Explain that the pupils are going to do a survey to find out if their lifestyle is healthy.
- 2 Put the pupils in pairs, A and B. Give out the Activity sheets and read through the questions in activity 1.
- 3 Discuss each question putting emphasis on the importance of regular exercise and a healthy diet.
- 4 Ask the pupils to take turns to ask and answer the questions.
- 5 Tell them to circle their partner's answers. They will need to write their partner's answer to question 10.
- 6 Explain that they will use the Tally chart in activity 2 to find out how healthy the whole class is.
- 7 Invite each pair in turn to share their questionnaire answers with the class. The class records the answers to questions 1, 7 and 9 on the Tally chart in activity 2 each time, using a ✓ for yes and a ✗ for no.
- 8 Demonstrate how to circle each group of 5 identical answers to the same question, for ease of adding up.
- 9 Discuss the results of the survey. Is the class healthy or unhealthy?

**Follow up**

- 1 Discuss ways to stay healthy and fit. Accept any reasonable suggestions and write them on the board.
- 2 Put the pupils into small groups. Give each group poster paper, coloured pencils, pictures of healthy and less healthy food and drinks, and of people exercising, scissors and glue.
- 3 Ask each group to design and make a poster to show how we can stay healthy and fit. Tell them to use the magazine pictures and to draw their own pictures to illustrate the poster, too.
- 4 Display the posters in the classroom.

**Useful website**

- [www.primaryresources.co.uk/science/science2b.htm](http://www.primaryresources.co.uk/science/science2b.htm)  
Click to use the resources

**Search term:** healthy diet

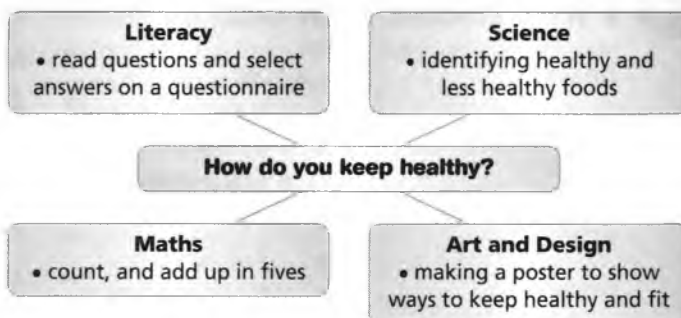
**Cross curricular links**

# How do you keep healthy?

## 1 Questionnaire

Ask and answer with a partner. Circle your partner's answers.

- 1 Do you do any exercise or sport? yes / no
- 2 What exercise do you do? run / swim / walk / football / tennis / gymnastics
- 3 When do you exercise? in school / after school / at the weekend
- 4 What do you eat for breakfast? bread / eggs / jam / butter / honey / meat / cheese / other
- 5 What do you usually eat for lunch? vegetables / meat / fruit / other
- 6 What is your favourite meal? breakfast / dinner / lunch
- 7 Do you eat fruit and vegetables each day? yes / no
- 8 What do you drink? water / milk / fruit juice / other
- 9 Do you eat sweets? yes / no
- 10 What is your favourite food? \_\_\_\_\_



## 2 Tally chart

Record each 'yes' answer with a ✓ and each 'no' answer with a X.  
Draw a circle around each group of 5 ticks or crosses for the same question.

1 Do you do any exercise or sport?		7 Do you eat fruit and vegetables each day?		9 Do you eat sweets?	
Yes	No	Yes	No	Yes	No

Lesson  
1b

## Diet. What did Little Red Hen eat?

**Fact box**

- Plants need sunlight, water and warmth to grow.
- Corn is ground into flour in a mill.
- Flour is mixed with water and yeast to make bread.
- Yeast makes the bread rise.

**Aims**

- To understand the importance of a healthy diet.
- To understand the conditions needed for plants to grow.
- To revise main meals of the day and farm animals.

**Language**

- Verbs: *busy, grind*
- Vocabulary: *breakfast, corn, dinner, flour, hungry, lunch, mill, sleepy, soil, sorry, sunlight, tired, water, yeast*

**Extra materials**

- 1 copy of the Activity sheet per pupil, Audio Track 6, Audio text, IWB
- 1 packet of grass or salad seeds, 1 plastic plate/shallow container and 1 paper towel per pupil

**Warm up**

- 1 Ask the pupils what they had for breakfast this morning.
- 2 Revise healthy and less healthy foods as discussed in Lesson 2.1a.
- 3 Use the pictures on the Activity sheet for Lesson 4.1a to show the stages of a seed growing into a plant.

**Procedure**

- 1 Talk about farm animals: *rat, dog, cat, hen*. Ask *What do these animals do on the farm?*
- 2 Ask the pupils to listen to the story of 'Little Red Hen' and play Audio Track 6 (see Audio text).
- 3 Give out the Activity sheets and ask them to look at activity 1. Look through the pictures and story of 'The Little Red Hen' with the class. Explain that they are in the wrong order.
- 4 Read through the sentences, or ask pupils to read them, and explain any words they do not understand.
- 5 Ask the pupils which picture comes first. Tell them to label it 1.
- 6 Put the pupils in pairs and tell them to number the other pictures in the correct order.
- 7 Display the IWB and complete Task 1 with the class to check their answers. Play the Audio again.
- 8 Discuss how the corn was made into flour and the flour was made into bread. Look at picture 3 and ask *Where was the corn made into flour? How did Little Red Hen do this?*
- 9 Talk about the pictures in activity 2. Ask *What can you see in picture 1? What can you see in picture 2? What is different in picture 2?* Tell pupils to circle 6 differences. Check the answers with the class.

**Follow up**

- 1 Tell the class that they are going to plant some seeds like Little Red Hen, but they will grow much faster.
- 2 Ask *What will the seeds need to make them grow?* (sunlight, water, warmth). Remind them of Little Red Hen and ask *Where did she plant her seeds?* Give a plate/container and a paper towel to each pupil.
- 3 Demonstrate the activity: put the paper towel on the plate, add a small amount of water, sprinkle seeds thinly over the towel, put the plate in a light, warm place and leave the seeds to grow. Water as required.
- 4 If salad seeds are grown, organise pupils to cut, wash and use the crop to make sandwiches with bread.
- 5 Discuss making bread. Ask *What do we need to make bread?* Look again at picture 4 showing Little Red Hen making bread with flour, water and yeast to make it rise.

**Useful website**

- [www.morrisqualitybakers.co.uk](http://www.morrisqualitybakers.co.uk)  
Click on *Breaducation Zone*

**Search terms:** healthy diet, making bread, growing seeds

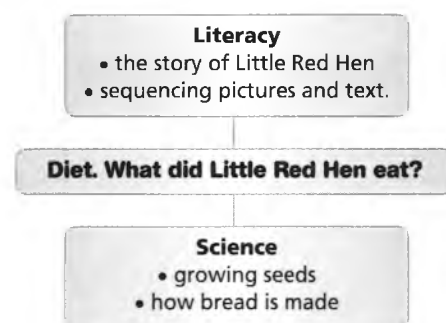
**Cross curricular links**

# What did Little Red Hen eat?

## 1 T6 Number the pictures

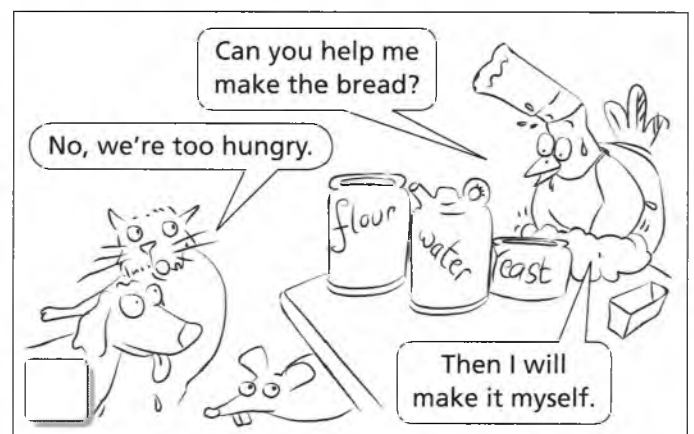
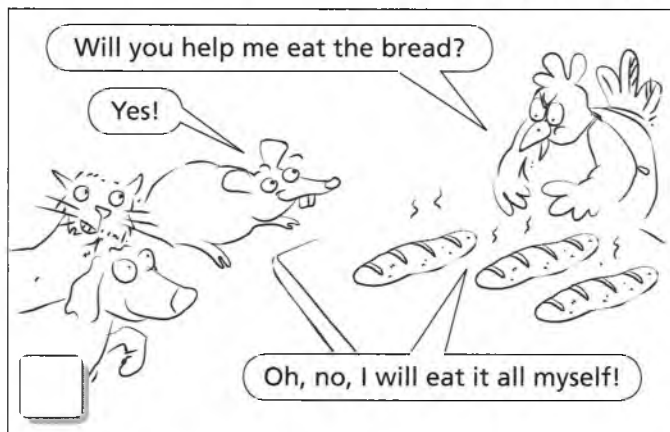

## 2 Find 6 differences



# What do you like to eat for lunch?

## Fact box

- **Fats give us energy.** They are found in foods like butter, oil, milk and cheese.
- **Carbohydrates give us fuel and energy.** They are found in foods like pasta, bread and cereal.
- **Protein helps us grow, and heal when we are hurt.** It is found in foods like meat, milk and nuts.
- **Fibre helps us digest our food.** It is found in foods like vegetables, fruit and cereal.

## Aims

- To understand and design a healthy diet.
- To understand the function of carbohydrates, proteins, fats and fibre.

## Language

- Vocabulary: *carbohydrate, cheese, fat, fruit, meat, milk, protein, vegetables, water*

## Extra materials

- 1 copy of the Activity sheet per pupil, Audio Track 7, Audio text, IWB

## Warm up

- 1 Organise pupils to sit in a circle and discuss what they eat for lunch. Ask *Do you have sandwiches or a cooked meal for lunch?*
- 2 Display the Audio text for Track 7 and read through the chant words with the class.
- 3 Play Audio Track 7. Ask the pupils to listen and follow the words.
- 4 Play the Audio again and say the chant with the pupils.
- 5 Divide the class into 2 groups. Ask group 1 to say the first verse, group 2 to say the second verse and then both groups to say verse 3 together.

## Procedure

- 1 Discuss the difference between healthy and less healthy food, as in Lesson 2.1b.
- 2 Give out the Activity sheets and tell the pupils to look at activity 1.
- 3 Ask different pupils each to name the food in 1 of the meals.
- 4 Tell the pupils to look at each pair of pictures and tick the healthy meal in each pair.
- 5 When they have finished, ask them to swap papers with their friend to check their answers.
- 6 Go through the answers with the class.

## Follow up

- 1 Share the information from the Fact box about different food types with the class.
- 2 Ask them to think of other examples of each food type.
- 3 Display the IWB for the pupils to complete the activity.

- 4 Ask the pupils which food type their favourite foods fall into. Discuss the job each food does, e.g. gives energy.
- 5 Talk about creating balanced meals by having food from each food group. Look at activity 2 and explain that the pupils are going to draw a healthy lunch on the plate.
- 6 Ask what they would like to draw in each section. Discuss which protein, vegetable and carbohydrate they would choose for the three sections.

## Useful websites

- [www.bbc.co.uk/schools/teachers/keystage\\_2/activities/pshe1.shtml](http://www.bbc.co.uk/schools/teachers/keystage_2/activities/pshe1.shtml)  
Use the best activities for your pupils.
- [www.tes.co.uk/teaching-resource/Ppt-healthy-eating-6009583](http://www.tes.co.uk/teaching-resource/Ppt-healthy-eating-6009583)  
Free registration. Click on *Activity-Interactive Whiteboard* next to *PPT*
- [www.tes.co.uk/teaching-resource/Healthy-eating-quiz-6033844](http://www.tes.co.uk/teaching-resource/Healthy-eating-quiz-6033844)  
Free registration. Click on *Game, puzzle, quiz-Interactive Whiteboard* next to *PPT*

**Search terms:** food, diet, healthy eating

## Cross curricular links

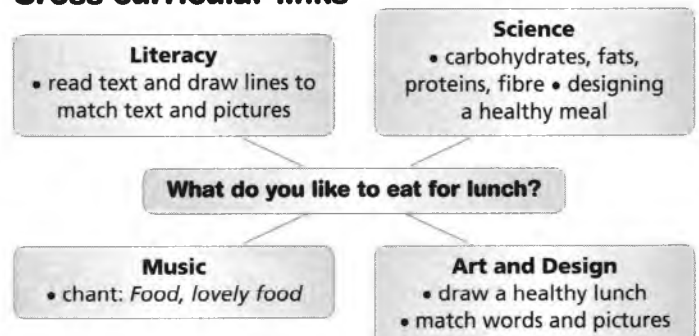

# What do you like to eat for lunch?

## 1 Choosing a healthy lunch

Tick the healthier meal

1

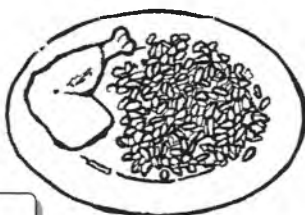
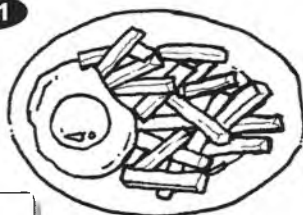

2

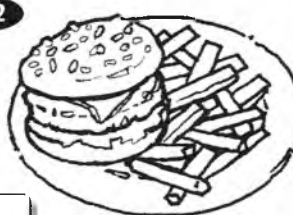

3



4



5



6



## 2 Draw your healthy lunch

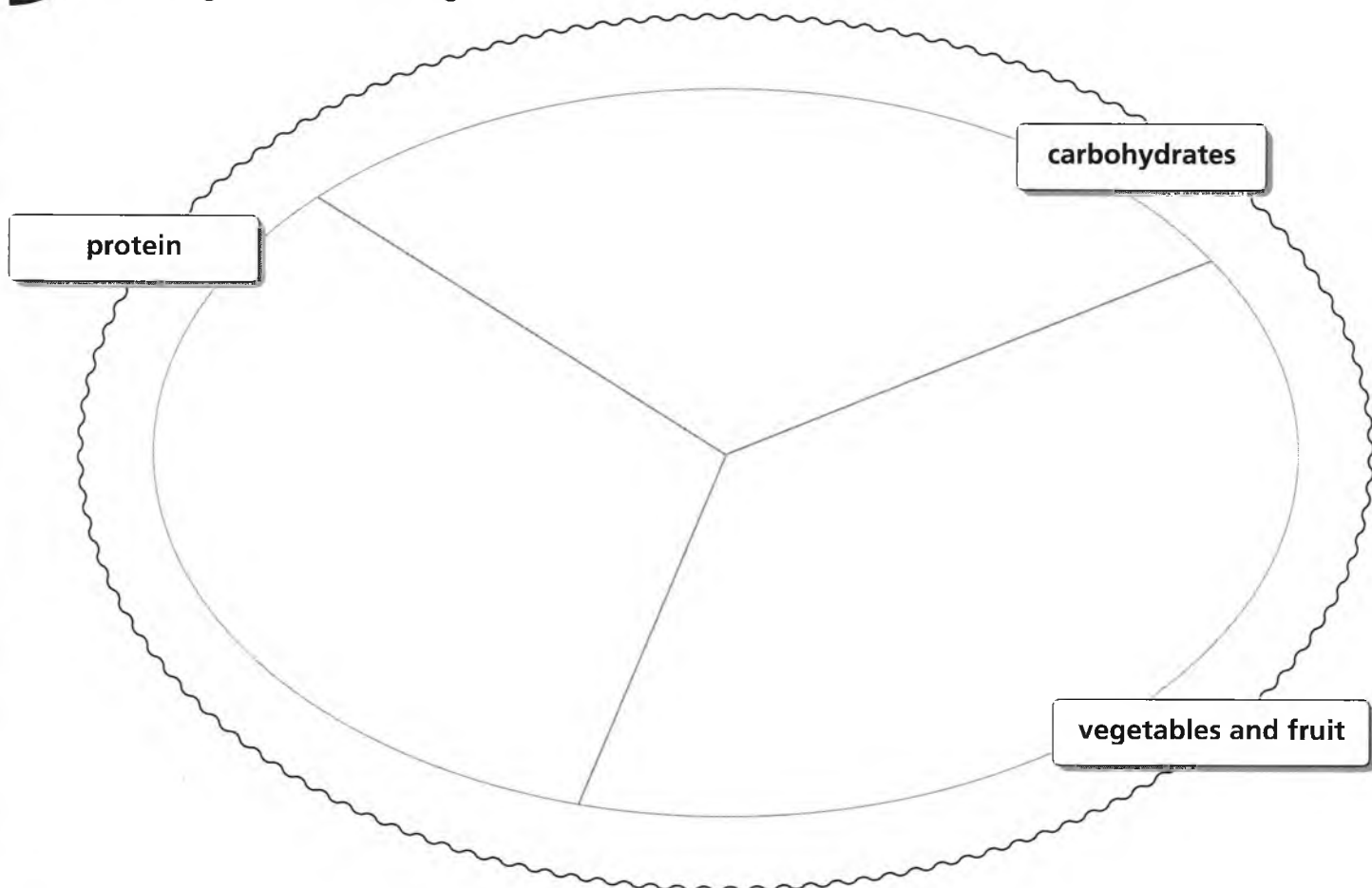

Lesson  
2b

## What's in Tim's sandwich?

## Fact box

- Children in Britain usually eat 3 meals a day.
- They often have cereal for breakfast and a hot drink.
- For lunch they often have a sandwich at school with some fruit and a cold drink.
- Some schools have a kitchen and cook a hot meal for the pupils' lunch.
- For the evening meal, they usually eat at 6pm and have a hot, cooked dinner.

## Aims

- To identify the main meals of the day.
- To recognise the difference between and compare pupils' traditional meals and British food.

## Language

- Nouns: days of the week
- Verbs: *shriek, squeeze, squirm*
- Adjectives: colours
- Ordinals & sequencing: *first, second, then, next, at last*
- Vocabulary: *ant, breakfast, bug, caterpillar, cucumber, diary, dinner, fly, lettuce, lunch, salad, slug, snail, worm*

## Extra materials

- 1 copy of the Activity sheet per pupil, Audio Track 7 from Lesson 2.2a, Audio Track 8, Audio texts, IWB
- coloured pencils

## Warm up

- 1 Play Audio Track 7 from Lesson 2.2a (display Audio text) and say and clap *Food, glorious food* again with the class.
- 2 Ask *What did you eat for breakfast? What did you have for lunch yesterday? Do you like sandwiches? How do you make a sandwich?*
- 3 Revise healthy foods from Lesson 2a and discuss what makes a healthy sandwich.

## Procedure

- 1 Teach verbs *shriek, squeeze* and *squirm*. Display the Audio text for Track 8. Revise the concept of rhyme.
- 2 Play Audio Track 8 and tell the pupils to follow the words as they listen.
- 3 Ask them to tell you any pairs of rhyming words they heard.
- 4 Give out the Activity sheets and ask the pupils to look at activity 1. Read through the words with the class.
- 5 Tell them to write in the missing rhyming words. Use Audio Track 8 to check the pupils' answers.
- 6 Look at activity 2. Ask the pupils to draw and colour Tim's sandwich and add any other insects they know.
- 7 Display the IWB for the pupils to complete the activity. Discuss what foods are edible and what foods are healthy.

## Follow up

- 1 Look at Activity 3 with the class. Read and revise the days of the week.
- 2 Explain that the pupils are going to keep a diary or record of what they eat at each main meal for a week.
- 3 Ask them *What do you usually eat for breakfast/lunch/dinner?* Write their answers on the board.

- 4 Tell the pupils to complete the diary for breakfast (and lunch if they've had it) today.
- 5 Ask them to take the sheet home, fill it in each day until it is complete and then bring it back to school.
- 6 After a week, ask the pupils to share their diaries with the class. Discuss what they have eaten and what kind of food a child would eat for each meal in Britain (see Fact box).
- 7 With the class, read *Sam's Sandwich* by David Pelham (Penguin Books, 1991, ISBN-13: 978-0525447511) and/or *The Giant Jam Sandwich* by JV Lloyd and J Burroway (Red Fox Picture Books, 2010, ISBN.13: 978-1849413442).

## Useful website

- [www.tes.co.uk/teaching-resource/Healthy-eating-Key-Fact-2-People-choose-different-types-of-food-6048252](http://www.tes.co.uk/teaching-resource/Healthy-eating-Key-Fact-2-People-choose-different-types-of-food-6048252)  
Free registration. Click on *Worksheet* or *Activity* next to *PDF* or *WEB*

**Search terms:** healthy eating, healthy diet

## Cross curricular links

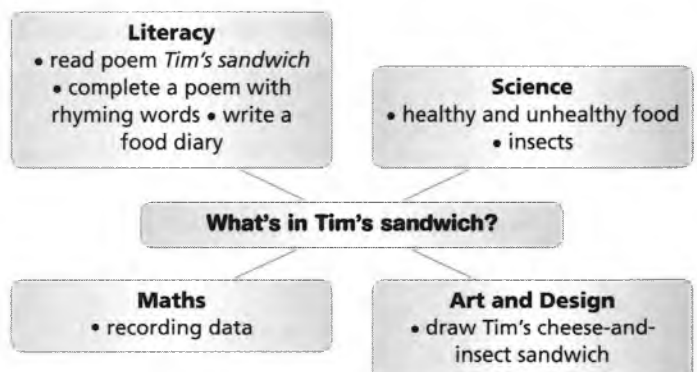

# What's in Tim's sandwich?

## 1 Tim's sandwich

**T8** Fill in the rhyming words

Tim had a naughty sister, \_\_\_\_\_.  
 One day she said 'I've got a \_\_\_\_\_.'  
 'Maybe you're hungry, Jane,' Tim \_\_\_\_\_.  
 'I'll make you a sandwich with some \_\_\_\_\_.'  
 First, he put in it a piece of \_\_\_\_\_.  
 And then he gave the sandwich a \_\_\_\_\_.  
 'I think I'll make this a special \_\_\_\_\_ - \_\_\_\_\_!  
 This is a sandwich she'll love to \_\_\_\_\_!'

## 2 Draw a picture of Tim's sandwich

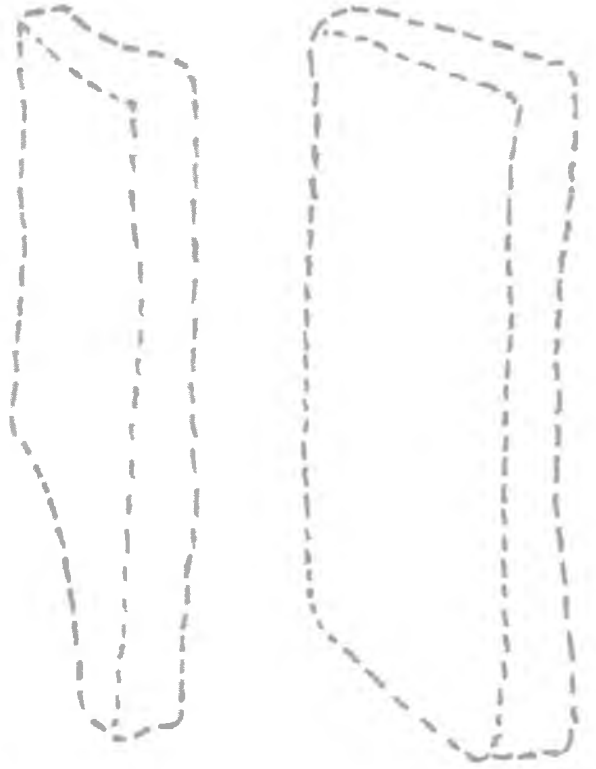

## 3 What do you eat?

My Food Diary			
	Breakfast	Lunch	Dinner
Monday			
Tuesday			
Wednesday			
Thursday			
Friday			
Saturday			
Sunday			

Lesson  
3a

## Illnesses and medicine

## Fact box

- Illnesses can be caused by bacteria or viruses.
- Medicines are drugs that help our bodies to recover from pain or disease.
- But there are some drugs – like tobacco in cigarettes and alcohol – that people use to change how they feel. These can harm them and may become addictive. People like the change so much that they want to take the drug again.
- Some drugs are legal and some drugs are illegal.

## Aims

- To be aware of health problems as a consequence of not looking after our bodies.
- To be aware of the importance of taking precautions to stop the spread of disease.
- To understand the use of medicines and drugs.

## Language

- Vocabulary: *bacteria, cold, cough, disease, headache, influenza, pain, sore throat, stomach ache, temperature, toothache, viruses, visit the dentist/doctor*

## Extra materials

- 1 copy of the Activity sheet per pupil, Audio Track 9, IWB
- scissors

## Warm up

- 1 Organise the pupils to sit in a circle for a class discussion. Ask *What do you do when you are ill?*
- 2 Discuss how we get colds, coughs and influenza and how bacteria and viruses cause illness (see 3.2b).
- 3 Talk about prevention by washing hands and by sneezing and coughing into a tissue.
- 4 Play the game 'I'm feeling ill' Write these illnesses on the board: *cold, cough, influenza, headache, stomach ache, toothache, temperature*. Explain that the pupils will take turns to play. Choose a pupil to begin. Pupil 1 says *I'm feeling ill*. You ask *What's the matter?* Pupil 1 chooses an illness on the board and replies, e.g. *I have a cold*. Pupil 2 says *I'm feeling ill*. You ask *What's the matter?* Pupil 2 replies *I have a ...*. Continue until each illness has been used then repeat until everyone has had a turn.
- 5 Discuss what pupils do if they are ill and what medicines they can have to make them better.
- 6 Talk about what happens when they visit the doctor or the dentist.
- 7 If there is time, act out a role play with a doctor and a patient.

## Procedure

- 1 Give out the Activity sheets. Allow the pupils time to look at activity 1.
- 2 Play Audio Track 9 and ask the pupils to listen and follow on the sheet.
- 3 Ask *What is Tim doing in picture 1?* Repeat the question for each picture.
- 4 Direct the pupils to cut the five pictures out and to mix them up. Put the pupils into pairs, A and B, and tell them to swap pictures. Each pupil must now put their partner's pictures into the correct order.

- 5 Display the IWB for the pupils to complete the activity.

## Follow up

- 1 Now look at activity 2 on the Activity sheet with the class. Ask seven pupils to read out one clue each.
- 2 When the class has guessed the answers, the pupils can write the words into the correct spaces.
- 3 Write the answers on the board when they have all finished.
- 4 Ask the pupils to swap papers with a friend and to mark the answers with a ✓ if correct or a ✗ if not.
- 5 Ask who has all answers correct.

## Useful website

- [www.abpishools.org.uk/page/resourcelibrary.cfm](http://www.abpishools.org.uk/page/resourcelibrary.cfm)  
Click the box to accept Terms & Conditions. Type *medicine* into the Keywords box and click *SEARCH*. Scroll down and click *Ellie's Medicine*.

**Search terms:** illnesses, medicines

## Cross curricular links

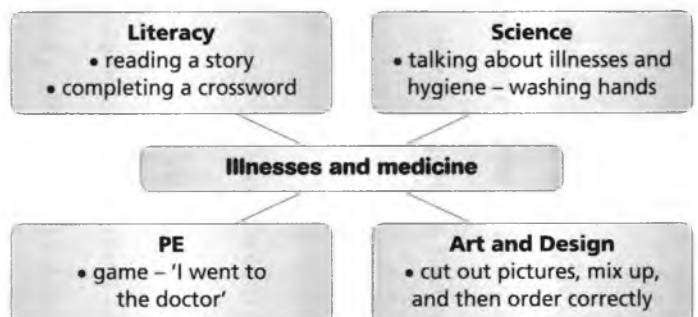

# Illnesses and medicine

## 1 T9 Tim's day in bed

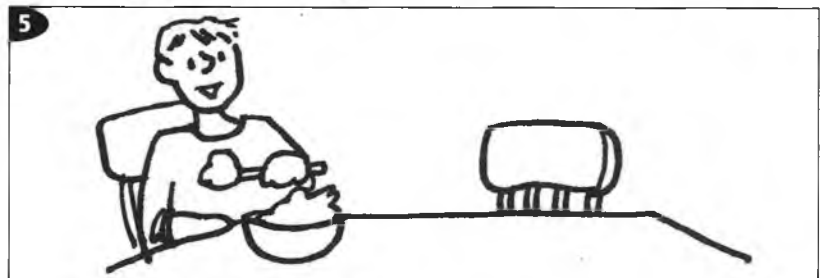
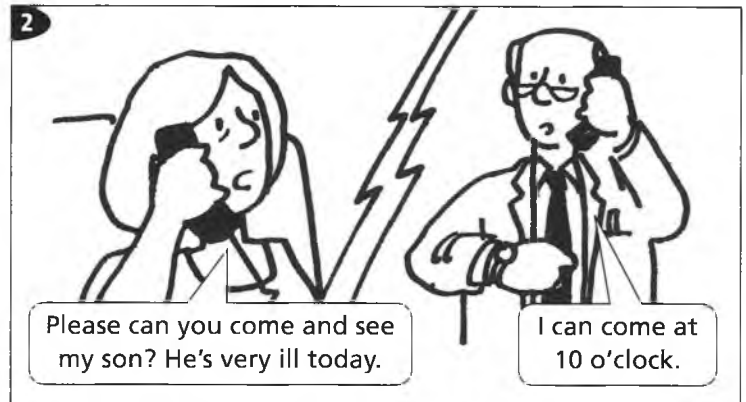

## 2 Complete the crossword

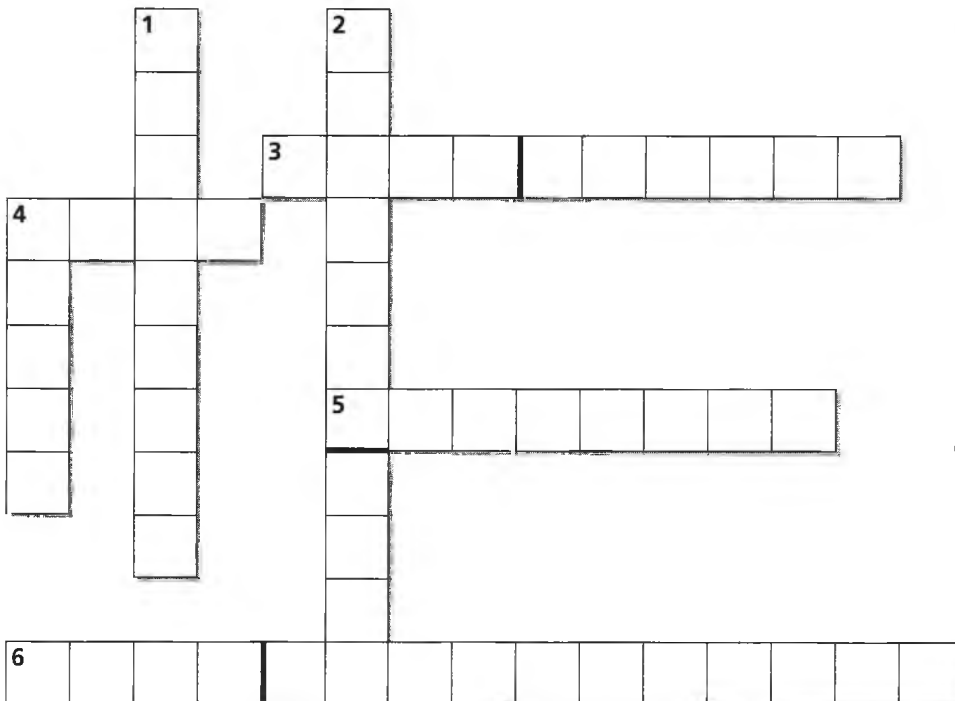

### Clues:

#### Across

- 3 Your throat hurts. (4, 5)
- 4 You sneeze a lot.
- 5 Your head hurts.
- 6 You feel very hot. (4, 11)

#### Down

- 1 You feel hot and you have a headache.
- 2 Your stomach hurts. (7, 4)
- 4 Your chest is irritating.

Lesson  
3b

## A visit to the hospital

## Fact box

- We can go to hospital when we are ill or in pain and injured.
- If we have an accident and are injured, we can go to hospital.
- Accidents can happen anywhere. We must be careful to stop accidents happening.

## Aims

- To learn about how accidents can happen, what to do when an accident has happened and how we can prevent accidents.
- To learn how to take responsibility for their own health and safety.

## Language

- Revise: parts of the body and illnesses
- Vocabulary: *accident, ailment, broken leg, illness, x-ray*

## Extra materials

- 1 copy of the Activity page per pupil, Audio Tracks 10 & 11, Audio text, IWB

## Warm up

- 1 Revise illnesses. Remind pupils of and briefly play the game 'I'm feeling ill' (Lesson 2.3a Warm up 4).
- 2 Teach a new game. Say *I went to the doctor's because I had a headache*. Tell a pupil to think of another ailment, repeat what you said and then say their ailment, e.g. *I went to the doctor's because I had a headache and stomach ache*.
- 3 Continue around the class until one person makes a mistake, then begin the game again with a new pupil.
- 4 Discuss how accidents happen and why we may need to go to hospital. Encourage pupils to share their own experiences.

## Procedure

- 1 Display the Audio text and read through the chant words with the class. Play Audio Track 10 and ask the pupils to listen and follow the words. Play the chant again and recite the chant with the class.
- 2 Talk about what happens when we go to hospital.
- 3 Give out the Activity sheets. Ask the pupils to look at the story in activity 1 and say what is happening.
- 4 Play Audio Track 11 and ask the pupils to listen and follow on their Activity sheets.
- 5 Ask 6 pupils to read the story, each taking a role: Boy 1, Boy 2, Dad, Receptionist, Doctor, Mother.
- 6 Repeat with other groups of 6 pupils until everyone has had a turn. Ask the class to retell the story.
- 7 Display the IWB for the pupils to complete the activity.

## Follow up

- 1 Ask the class to look at the gapped sentences in activity 2 on the Activity sheet.
- 2 Read through the sentences with the pupils, and then ask them to fill the gaps.
- 3 When they have finished put the pupils into pairs to read their completed sentences to each other.
- 4 Read the completed sentences to the class (insert: 1 hurt, leg; 2 phones; 3 straight, hospital; 4 x-ray; 5 stay, two weeks) and tell the pupils to check their work
- 5 Explain that they can now write the story in their own words using the pictures to help them.
- 6 If there is time, the pupils can make a simple book to write the story in and illustrate it with their own drawings. Display the pupils' story books in the class.

## Useful websites

- [www.bbc.co.uk/northernireland/schools/4\\_11/potato/pdf/summer2005/pr04.pdf](http://www.bbc.co.uk/northernireland/schools/4_11/potato/pdf/summer2005/pr04.pdf)
- [kidshealth.org/kid/ill\\_injure/index.html](http://kidshealth.org/kid/ill_injure/index.html)  
Click on links to different illnesses

**Search terms:** ailments, illnesses, going to hospital

## Cross curricular links

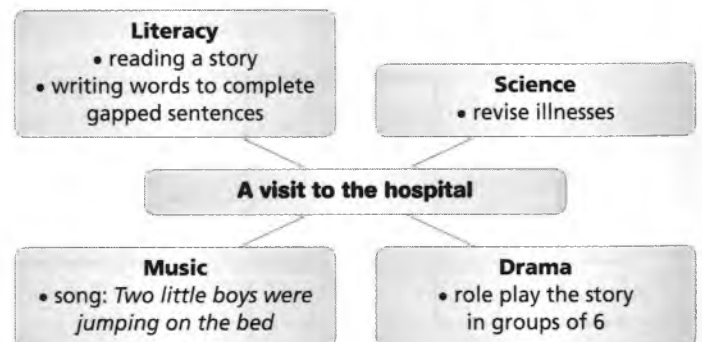

# A visit to the hospital

## 1 The accident



## 2 Fill in the gaps

- 1 John \_\_\_\_\_ his \_\_\_\_\_.
- 2 He \_\_\_\_\_ his dad.
- 3 He went \_\_\_\_\_ to the \_\_\_\_\_.
- 4 The doctor said he must have an \_\_\_\_\_.
- 5 He must \_\_\_\_\_ at home for \_\_\_\_\_.

# Animals, plants and their habitats

## Where do they live?

### Fact box

- A habitat is a place where an animal or a plant lives.
- Different animals and plants are found in different habitats.
- Habitats can be big, like a forest, or small, like a leaf.
- A habitat provides water, food, shelter, other animals or plants.

### Aims

- To establish links between different animals, plants and habitats.

### Language

- Vocabulary: *animal, ant, bird, bumble bee, camel, cow, crab, desert, duck, elephant, farm, fish, fox, frog, hen, horse, insect, kangaroo, land, monkey, mouse, owl, parrot, pig, plant, polar bear, pond, rainforest, sea, shark, sheep, snake, spider, wasp, water, woodland*

### Extra materials

- 1 copy of the Activity page per pupil, Audio Track 12, Audio text, IWB
- scissors, glue sticks, coloured pencils, 1 small ball

## Warm up

- 1 Display the Audio text for Track 12. Play Audio Track 12 and listen to the song then read the words with the class.
- 2 Play the song again and ask the pupils to sing along. Ask *How does an elephant walk/an insect fly/a kangaroo jump?* Play the song again and ask the pupils to mime the animals as they sing.
- 3 Divide the class into three groups. Tell each group to sing a different verse and do the mime for it.
- 4 Talk about each of the animals. Ask *Where do they live? Why? What do they do? What do they eat?*

## Procedure

- 1 Give out the Activity sheets and ask the pupils to look at the 4 different habitats. Ask the pupils to name and describe each habitat (farm with woodland and pond, rainforest, sea with ice-covered land, desert).
- 2 Ask *What does a habitat provide?* Talk about the food, water, shelter, animals and plants in each habitat.
- 3 Ask the pupils what kinds of animals live in each habitat. Discuss what it is like to live in these places.
- 4 Look at the animal pictures. Display IWB Task 1 and complete the activity with the class. Ask about each animal on the Activity sheet: *Where does it live? Why does it live there?*
- 5 Ask *Which animals live on the farm/in the woodland/on the pond?* Repeat the question for each habitat.
- 6 Ask the pupils to colour the animal pictures and stick each on the picture showing its habitat.
- 7 Display IWB Task 2 and complete the activity for the pupils to check their answers.

## Follow up

- 1 Ask the pupils to name other animals that live on a farm, e.g. goat, dog, cat. Repeat for the other habitats.

- 2 Discuss what each animal needs and what each habitat provides.
- 3 Play 'Land, air, water'. Write the names of the 3 habitats on the board and ask the pupils to sit in a circle. Throw the ball to any pupil and say *Air*. The pupil catches the ball and names an animal that flies in the air, throws the ball to another pupil and says *Land*. That pupil catches the ball and names an animal that lives on land, throws the ball to another pupil and says *Water*. That pupil catches the ball and names an animal that lives in the water. Continue round the class. Each pupil must name a different animal.
- 4 If there is time, divide the class into 3 groups, one for each habitat. Tell them to use the Internet to find more information about the animals which live in their habitat, and to draw their own pictures.

### Useful website

- [www.woodlands-junior.kent.sch.uk/revision/Science/index.html](http://www.woodlands-junior.kent.sch.uk/revision/Science/index.html)

Click on *Habitats* and select an activity.

**Search term:** animal habitats

### Cross curricular links

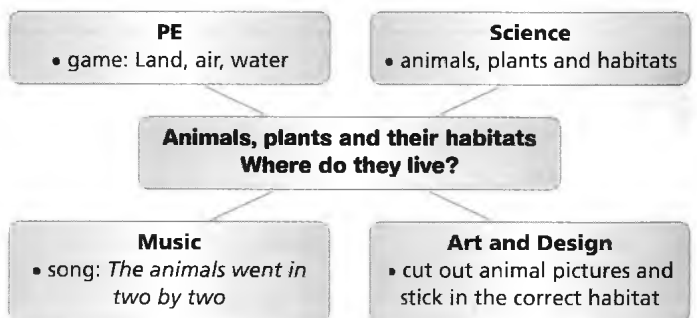

# Where do they live?

## Animals and their habitats

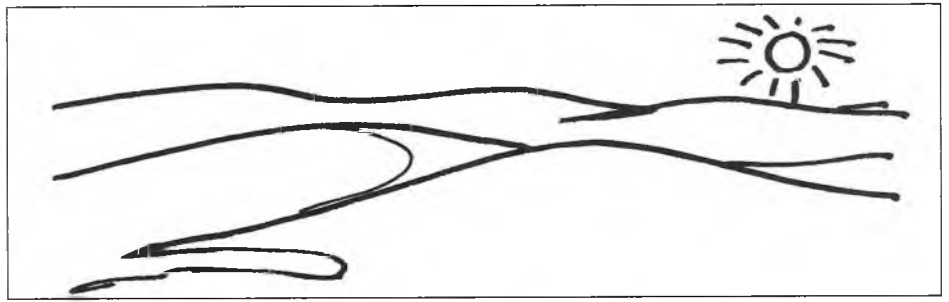
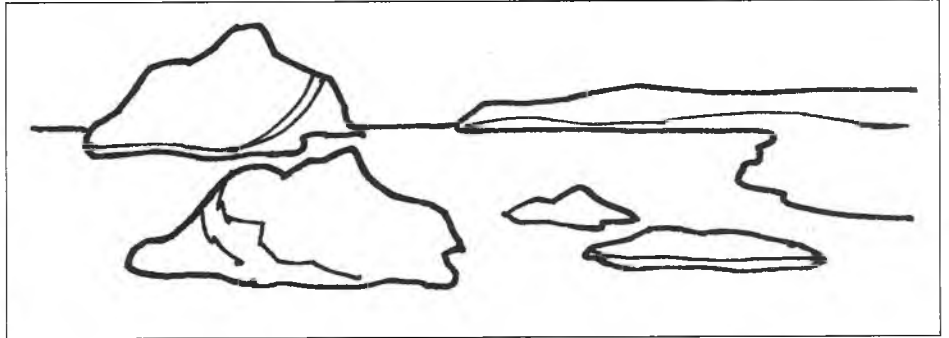

### Cut and stick



# What can you find around here?

## Fact box

- A vertebrate is a creature with a backbone.
- An invertebrate is a creature without a backbone.
- Insects are invertebrates.
- Carnivores eat meat.
- Herbivores eat plants.
- Omnivores eat meat and plants.

## Aims

- To observe conditions in a local habitat and record the animals seen.
- To learn that animals are suited to their environments.
- To understand the difference between vertebrates and invertebrates.

## Language

- Vocabulary: *animal, ant, bee, carnivore, caterpillar, herbivore, insect, invertebrate, ladybird, mini beast, mouse, omnivore, plant, slug, snail, spider, vertebrate, woodlice, woodlouse, worm*

## Extra materials

- 1 copy of the Activity page per pupil, IWB
- pictures of insects found in your area, e.g. spider, worm, slug, snail, caterpillar, butterfly, moth, ladybird, woodlouse, grasshopper, ant, bee; 1 net and 1 collecting pot with lid per small group of pupils

## Warm up

- 1 If you have these available, display the pictures of insects and talk about those found in your area.
- 2 Explain that *mini beasts* are small insects. Discuss the meaning of *vertebrate* and *invertebrate*. Establish that insects are invertebrates and, because they have no backbone, they can move about more easily.
- 3 Discuss the kinds of animals and mini beasts the pupils have seen in your school environment.
- 4 Ask about each insect: *Does it have a hard shell to protect it? Does it have wings so it can fly? Is it wet or dry? Can it sting or bite when it is attacked?*

## Procedure

- 1 Display the IWB and complete the activity with the class.
- 2 Draw a map of the school and its grounds on the board. Identify possible locations to look for creatures.
- 3 Give out the Activity sheets and ask the pupils to draw their own map of the school and its grounds.
- 4 Put the pupils into small groups and give each group a net and a collecting pot.
- 5 Go to a good wildlife area and suggest good habitats for insects – under stones or logs or in long grass.
- 6 Tell the pupils to net an example of each insect and transfer it to their pot. It is important that the pupils should not touch the insects.
- 7 Tell the pupils to mark the location of each habitat on their maps and to record the insects found in each.
- 8 In the classroom, give each group a turn to mark the habitats where they found mini beasts on the map you drew and to show the insects they caught. List the insects found in each habitat on the board.
- 9 Identify each insect. Discuss any special features. Ask *What does it look like? How many legs has it got?*

- 10 Ask *What do they eat – other insects or plants or both?* Explain that meat-eating creatures are *carnivores*, plant-eating creatures are *herbivores* and *omnivores* eat both meat and plants.

## Follow up

- 1 Look at activity 2 and revise the meanings of the headings on the diagram.
- 2 Read through the list of animals and insects with the pupils and ask what they think each one eats.
- 3 Tell them to write the name of each creature on the Activity sheet in the correct circle on the Venn diagram, according to what it eats. Go through the answers with the class.

## Useful websites

- [www.primaryresources.co.uk/science/powerpoint/mini beasts\\_WWtbaM.ppt](http://www.primaryresources.co.uk/science/powerpoint/mini beasts_WWtbaM.ppt)
- [www.primaryresources.co.uk/science/pdfs/habitatsheets.pdf](http://www.primaryresources.co.uk/science/pdfs/habitatsheets.pdf)

**Search terms:** habitats, vertebrates, invertebrates, carnivores, herbivores

## Cross curricular links

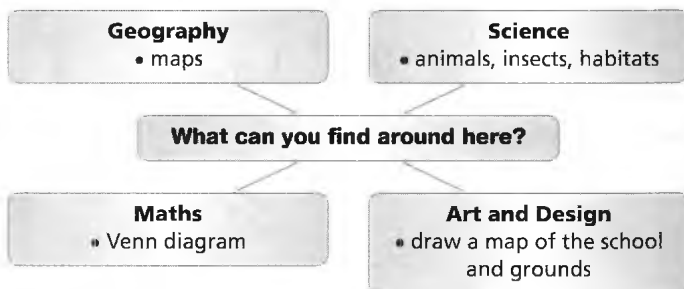

# What can you find around here?

## 1 Creatures around our school

Draw a map of your school and its grounds. Mark the places where you find creatures. Draw the trees, stones and other hiding places where the creatures live.

## 2 Venn diagram

Write the names in the correct circle.

**Insects:** spider, ant, ladybird, caterpillar, slug, snail, worm, bee, woodlouse, grasshopper, fly

**Animals:** cow, sheep, horse, pig, hen, duck, frog, elephant, kangaroo, owl, fox, mouse, shark, crab

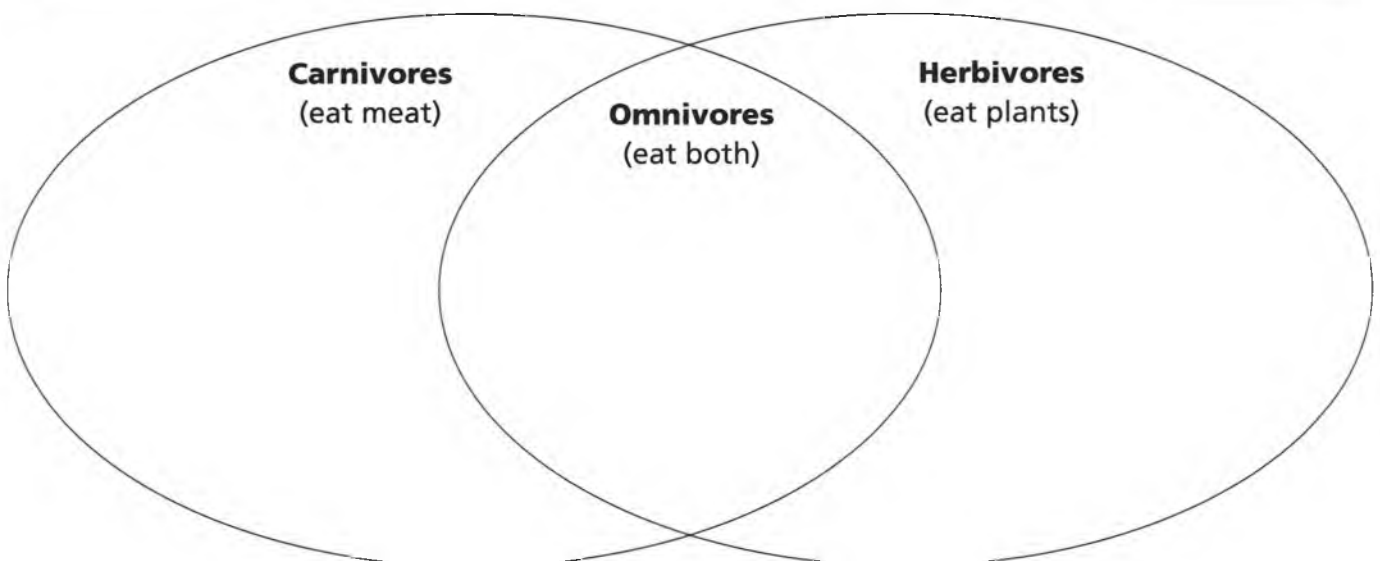

Lesson  
2a

## The food chain

## Fact box

- All food chains start with the sun.
- The sun is a producer.
- A plant absorbs light from the sun.
- A plant is a consumer.
- An animal eats the plant.
- A consumer usually eats the producer.

## Aims

- To order living things in simple food chains.
- To observe living things existing together in a habitat.

## Language

- Ordinals: *1st, 2nd, 3rd, 4th, 5th*; Sequencing: *First, Next, Then, Last*
- Vocabulary: *animals, butter, carnivores, cheese, consumer, ecosystem, food chain, herbivores, insects, milk, plants, producer, sometimes, usually, yoghurt*

## Extra materials

- 1 copy of the Activity page per pupil, IWB
- card, scissors, thread, glue sticks, sticky tape, coloured pencils, book: *There was an old woman who swallowed a fly*, illustrator: Pam Adams, Child's Play (International) Ltd, 2000, ISBN-10: 0859537277

## Warm up

- 1 Ask *What have you eaten today?* Talk about how we get our energy and what we need to move and grow.
- 2 Ask *Where does our food come from?* Write on the board: *from animals, from the ground, from plants.* Ask pupils to name a food they know and write it under the correct heading.
- 3 Write *milk, cheese, butter, yoghurt* on the board. Ask *What are these made of?* Elicit *Milk.* Ask *Where does milk come from?* Elicit *Cows.* Ask *What do cows eat?* Elicit *Grass.* Explain that this is a food chain.
- 4 Talk about habitats (see Lesson 3.1a) and how food chains are different in different places.

## Procedure

- 1 Give out the Activity sheets. Look at activity 1. Ask the pupils to name the pictures in the top row.
- 2 Tell them to draw arrows to show the order in which the energy/food is consumed.
- 3 Explain that food chains usually start with the sun, then a plant. The sun is called a producer and plants use energy from the sun to grow. The cow eats grass so it is a consumer. It gives us milk so it is a producer, too. Humans drink milk and eat meat from a cow, so they are consumers.
- 4 Pupils colour the pictures and cut out the cards. In groups of 4, using 1 or 2 sets, pupils mix the cards and spread them face down on the table. Taking turns to pick a card, and starting with the 1st card of a food chain, they collect all cards in the chain, replacing any others. When a chain is complete, they begin another. When all cards are taken, the person with the most complete chains in the correct order wins.
- 5 Ask 4 pupils to stand facing the class, each displaying a card from one food chain. Ask *Which comes first/second/third/last?* until they are standing in order. Repeat with other pupils and food chains.

- 6 Display the IWB for the pupils to complete the activity.

## Follow up

- 1 Look at activity 2 on the Activity sheet. Read the headings with the class. Revise the meanings of *producer* and *consumer*.
- 2 Pupils draw and colour their own food chain. Ask them to say if each picture shows a producer or a consumer.
- 3 Demonstrate how to cut out the pictures to make a mobile. Thread them in order, with the sun at the top.
- 4 If time allows, read the poem *There was an old woman who swallowed a fly*. Ask *Can these creatures eat each other?* Talk about the rhyming words *fly/why, spider/inside her*, etc.

## Useful website

- [www.rspb.org.uk/youth/learn](http://www.rspb.org.uk/youth/learn)  
Click *Food chains*

**Search term:** food chains

## Cross curricular links

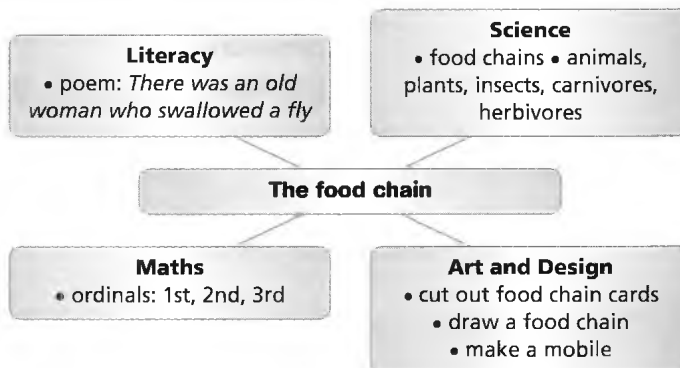

# Food chain cards

## 1 Play the food chain game

Add arrows. Colour and cut out.

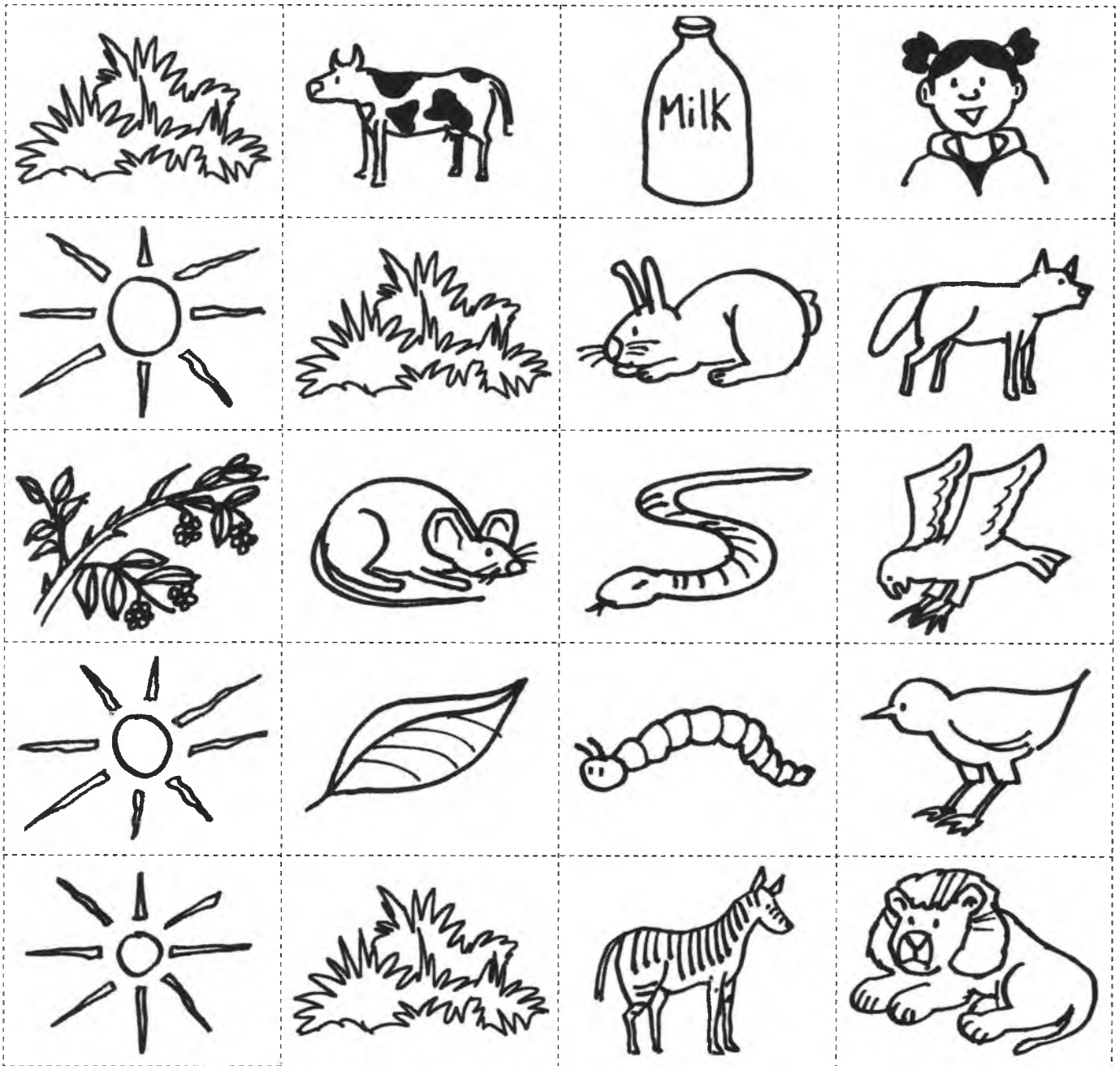

## 2 Draw your own food chain. Make a mobile

← Producers →

sun

plant

← Consumers →

animal herbivore

animal carnivore



# Micro-organisms

## Fact box

- Micro-organisms are very tiny living things.
- They include bacteria, viruses and fungi.
- They are usually too small to be seen.
- Some are useful; some are harmful.
- Useful micro-organisms are an important part of food chains: they break down, or decompose, dead plant and animal material and return it to the soil so it can be used again.
- Useful micro-organisms are used to make yoghurt and cheese.
- Harmful ones cause illness and disease.

## Aims

- To identify micro-organisms as living things.
- To recognise their distinguishing features.
- To recognise their beneficial or harmful properties.

## Language

- Revise food chain language from Lesson 3.2a
- Vocabulary: *bacteria, decompose, digestion, fungi, fungus, micro-organism, microscope, virus*

## Extra materials

- 1 copy of the Activity page per pair of pupils, IWB
- [www.channel4learning.com/sites/essentials/science/life/interface?type=image&parameter=Micro-organisms](http://www.channel4learning.com/sites/essentials/science/life/interface?type=image&parameter=Micro-organisms)
- 1 die and 2 counters or buttons + 1 magnifying glass + 1 x 10cm sticky tape per pair of pupils, a microscope

## Warm up

- 1 Recap food chains from Lesson 3.2a and the causes of diseases from Lesson 2.3a.
- 2 Discuss how we can prevent diseases from spreading by washing our hands and keeping clean.
- 3 Write the words listed as Vocabulary on the board. Practise the spellings and teach the correct pronunciation and meaning for each word.
- 4 If possible, go to the website listed in Extra materials (28 in WEB RESOURCES) to display the pictures of micro-organisms.
- 5 Share the information in the Fact box with the class.
- 6 Explain that micro-organisms live on food and food that is not kept fresh will decay and can cause food poisoning.

## Procedure

- 1 Discuss the sorts of places where harmful bacteria live. Ask *Where do you think the harmful bacteria are in the classroom?*
- 2 Put the pupils into pairs and give out the sticky tape.
- 3 Explain that they are going to walk around the classroom to collect any dust on their sticky tape. Demonstrate how to wrap the tape around their finger and touch the floor or dusty corners with it.
- 4 Tell them to remove the tape and look at the dust with the magnifying glass.
- 5 If possible, use a microscope too. Ask pupils what they can see.
- 6 Display the IWB for the pupils to complete the activity.

## Follow up

- 1 Put the pupils into pairs, A and B, and give out the Activity sheets. Tell them to look at the game.
- 2 Explain how to play. Tell the pupils to place their counters on *Start*. Pupil A throws the die and moves his/her counter along the board for the number of spaces on the die. He/she reads and follows the instructions on that square. Then pupil B has a turn. The first person to reach *Finish* is the winner.

## Useful websites

 (see also Extra materials above)

- [www.bbc.co.uk/schools/teachers/ks2\\_lessonplans/science/micro\\_organisms.shtml](http://www.bbc.co.uk/schools/teachers/ks2_lessonplans/science/micro_organisms.shtml)
- [www.tes.co.uk/teaching-resource/Microbes-in-Pictures-Starter-for-KS3-Microbes-topic-3005386](http://www.tes.co.uk/teaching-resource/Microbes-in-Pictures-Starter-for-KS3-Microbes-topic-3005386)  
Click on *Other* next to *PPT*. For Lower Secondary

**Search terms:** micro-organisms, fungi, bacteria



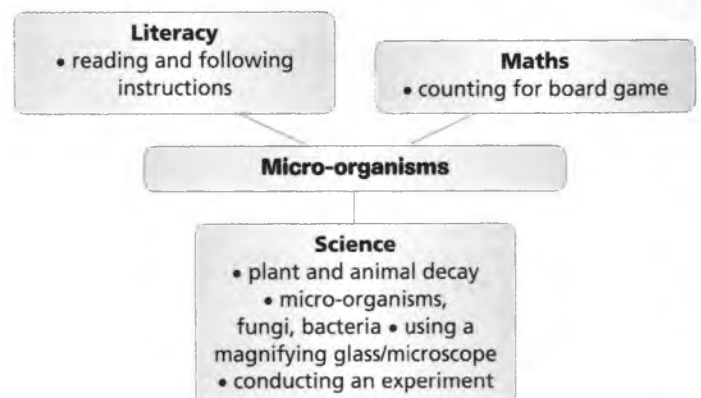







## Cross curricular links

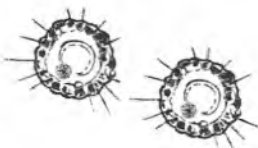

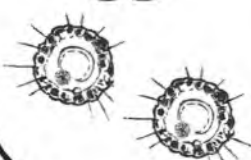
# Micro-organisms

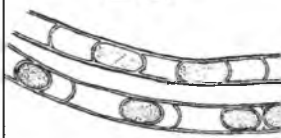
## Play the micro-organism game

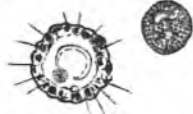
**START**

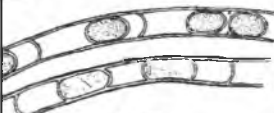
<p><b>1</b></p> 		<p><b>2</b></p> <p>Micro-organisms break down the leaves. Go to 5.</p>	<p><b>3</b></p> 	<p><b>4</b></p> <p>You catch measles. Go back to 1.</p>
<p><b>19</b></p> <p>You don't clean your teeth. Go back to 16.</p>	<p><b>20</b></p> <p>Miss a turn.</p>	<p><b>21</b></p> 	<p><b>22</b></p> <p>What do viruses do? Go to 26.</p>	<p><b>5</b></p>
<p><b>18</b></p>	<p><b>32</b></p>	<p><b>34</b></p>	<p><b>35</b></p> <p>What do good bacteria do?</p>	<p><b>23</b></p> 
<p><b>17</b></p>	<p><b>31</b></p>	<p><b>39</b></p>	<p><b>40</b></p> 	<p><b>24</b></p>
<p><b>16</b></p>	<p><b>30</b></p> <p>Miss a turn.</p>	<p><b>38</b></p> 	<p><b>37</b></p> 	<p><b>25</b></p> <p>What do bacteria do? Go to 29.</p>
<p><b>15</b></p>	<p><b>29</b></p>	<p><b>28</b></p> 	<p><b>27</b></p> <p>You eat some mouldy bread. Go back to 23.</p>	<p><b>26</b></p> 
<p><b>14</b></p> <p>You wash your hands. Go to 17.</p>	<p><b>13</b></p> 	<p><b>12</b></p> <p>You catch a cold. Go back to 8.</p>	<p><b>11</b></p> 	<p><b>10</b></p> 

# Animals in danger

## Fact box

- When animals are extinct, they have died out completely and there are no more of their kind left.
- Today 7,200 kinds of animals are facing extinction.
- They are called endangered animals.

## Aims

- To identify living things that are rare.
- To identify the problems of survival.

## Language

- Revise language for habitats from Unit 3 Lesson 1a
- Vocabulary: *black bear, both, danger, environment, gorilla, leopard, panther, polar bear, rhinoceros, snake*

## Extra materials

- 1 copy of the Activity page per pupil; IWB; pictures of animals: black bear, polar bear, panther, leopard, gorilla, snake, rhinoceros

## Warm up

- 1 If you have these available, display the animal pictures. Ask about each *What is this animal called? Where does it live?*
- 2 Display the IWB for the pupils to complete the activity.
- 3 Explain that these animals often lose their habitats when land is cleared for farming or building. Some are killed for food and medicines or for their fur and others are killed by pollution and global warming.
- 4 Discuss what is being done to try to save these animals by looking after their environments.

## Procedure

- 1 Write the names of the animals in the pictures on the board. Ask more about them: *Which of these animals lives only in a hot country?* (panther, leopard, gorilla, rhinoceros) ... *lives only in a cold country?* (black bear, polar bear) ... *lives in hot and cold countries?* (snake) ... *eats only meat?* (polar bear, panther, leopard) ... *eats only plants?* (gorilla, , rhinoceros) ... *eats meat and plants?* (black bear, snake) ... *has legs?* (black bear, polar bear, panther, leopard, gorilla, rhinoceros) ... *does not have legs?* (snake) ... *has fur or hair?* (black bear, polar bear, panther, leopard, gorilla) ... *does not have fur or hair?* (snake, rhinoceros)
- 2 Ask the pupils to choose 1 animal each from the list on the board.
- 3 Give out the Activity sheets. Read through the questions and the instructions in activity 1 with the class.
- 4 Put the pupils into pairs. Tell the pupils to ask their partner the questions and to tick or cross the questions for themselves and their partner.
- 5 Look at the Venn diagram. Tell pupils to write the names of their animals above the diagram. Read the headings in the diagram.
- 6 Tell them to write the numbers of any questions with 2 ticks or 2 crosses in the middle circle (*same*) and the numbers of the questions with a tick and a cross in the outside circles (*different*).

- 7 Now tell them to write about how their animals are different and the same.

## Follow up

- 1 Look at activity 2 and ask 7 pupils each to read the name of an endangered animal from the list. After each word, tell the class to spell out the letters, e.g. *G, o, r, i, l, l, a.*
- 2 Tell the pupils to look in all directions (like the arrows) to find and mark the words in the word search.
- 3 In pairs, pupils compare their answers. Then they take turns to ask and answer *How do you spell ...?*
- 4 For homework, ask pupils to research 1 animal in danger and make a poster to show the class next lesson.

## Useful websites

- [www.kidsplanet.org/factsheets/map.html](http://www.kidsplanet.org/factsheets/map.html)  
Click on the animals you want to know more about
- [www.abcteach.com/free/u/unscramble\\_endangered\\_species1.pdf](http://www.abcteach.com/free/u/unscramble_endangered_species1.pdf)

**Search term:** animals in danger

## Cross curricular links

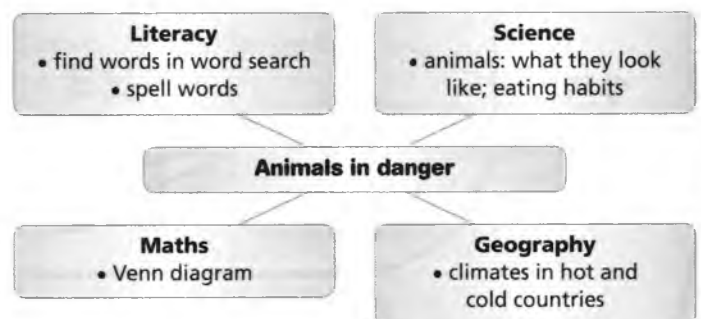

# Animals in danger

## 1 Choose an endangered animal

Answer, ask and record.

- 1 Does your animal live in a hot country?
- 2 Does your animal live in a cold country?
- 3 Does your animal eat plants?
- 4 Does your animal eat meat?
- 5 Does your animal eat both?
- 6 Does your animal have fur or hair?
- 7 Does your animal have legs?

You	Friend

If the answer is *No* put a ✕.  
 If the answer is *Yes* put a ✓.  
 Look at each answer.  
 If you have 2 ticks or 2 crosses then the animals are the same. Write the question number in the middle circle.  
 If you have 1 cross and 1 tick then the animals are different. Write the question number in an end circle.

Write the names of the animals. Complete the diagram with numbers.  
 Write how your two animals are different and the same.

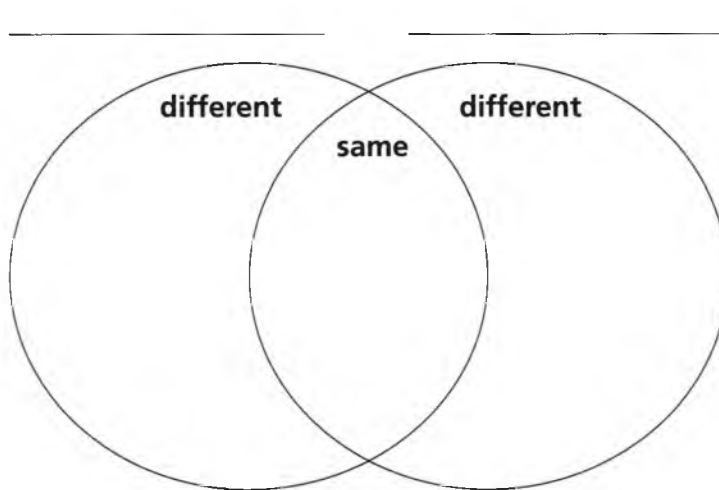

The \_\_\_\_\_

\_\_\_\_\_

The \_\_\_\_\_

\_\_\_\_\_

They both \_\_\_\_\_

\_\_\_\_\_

## 2 Find the animals in danger

- black bear
- gorilla
- leopard
- panther
- polar bear
- rhinoceros
- snake

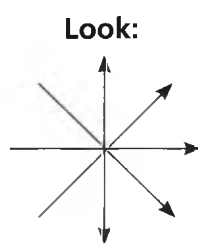

S	B	S	R	F	T	W	G	D	C	R
O	L	N	A	F	P	Y	Q	X	L	W
R	A	A	E	L	W	M	W	X	L	N
E	C	K	B	N	E	M	P	K	Z	R
C	K	E	R	T	G	O	K	K	E	X
O	B	D	A	P	L	W	P	H	N	R
N	E	R	L	G	C	T	T	A	K	J
I	A	P	O	L	Z	N	K	K	R	K
H	R	J	P	K	A	N	R	L	B	D
R	Z	B	J	P	Z	T	R	P	Q	J
B	T	P	M	G	O	R	I	L	L	A

# Prehistoric animals: dinosaurs

## Fact box

- Dinosaurs were reptiles that lived on Earth about 165 million years ago.
- They became extinct because their habitat changed.
- We know what some dinosaurs looked like because we have found their fossils.
- Many dinosaurs ate plants.
- Many also killed other dinosaurs.

## Aims

- To identify living things that are now extinct.

## Language

- Revise vocabulary from Lessons 1.2a, 3.1a and 3.3a
- Adjectives: *big, long, pointed, sharp*
- Vocabulary: *bone, dinosaur, diplodocus, fossil, prehistoric, pterodactyl, skeleton, stegosaurus, tyrannosaurus rex*

## Extra materials

- 1 copy of the Activity page per pupil, Audio Track 13, Audio text, IWB
- coloured pencils, a pair of scissors, a sheet of A4 paper and 4 split pins per pupil
- pictures of pterodactyl, diplodocus, stegosaurus, tyrannosaurus rex; skeleton of T rex



## Warm up

- 1 If you have these available, display the pictures of the dinosaurs. Ask *What can you see in the pictures? Do you know the name of any of these creatures? What kind of habitat did dinosaurs live in?*
- 2 Write the dinosaur names on the board. Read each name and ask the class to repeat.
- 3 Ask *What do they look like? What did they eat? What is different about the pterodactyl? Why could it fly?*
- 4 Share the information in the Fact box and discuss why dinosaurs became extinct.
- 5 Display the IWB for the pupils to complete the activity.

## Procedure

- 1 Ask the pupils to feel the bones of their ribs, arms and legs. Refer them to the pictures in Lessons 1.1a and 1.2a. Ask *What do our skeletons look like? Ask which bones they use to move their bodies along.*
- 2 If you have it available, display the picture of the T rex skeleton.
- 3 Give out the Activity sheets. Look at activity 1. Explain that it shows part of a dinosaur and its skeleton. Ask *Which dinosaur is this? (tyrannosaurus rex) What does it need to make it move along? (arms and legs)*
- 4 Show the T rex pictures again and point to the parts missing from the Activity sheet.
- 5 Give out the equipment. Tell the pupils to cut out the dinosaur body and place it on the A4 sheet.
- 2 Play Audio Track 13. Pupils listen and follow the instructions to complete the dinosaur with skeleton. If you read the dictation, pause after each line for pupils to draw. Repeat and wait for slower pupils.

- 7 Tell pupils to remove the cut-out body and lengthen, round off and colour the tops of the limbs (they must be long enough to attach to the body), then cut them out.
- 2 Demonstrate making holes as marked and attaching limbs to body with split pins for the dinosaur to move.

## Follow up

- 1 Look at activity 2. Ask the pupils to read and then spell the names of the dinosaurs outside the maze.
- 2 Tell them to draw a different coloured line from each dinosaur along the letter trail through the maze to spell its name. Ask *Which dinosaur reached its friend in the middle first?*
- 3 Ask them to compare mazes with a partner and take turns to ask *Which way did you go with the ...?*
- 4 For homework, ask pupils to find information about other dinosaurs on the Internet to share next lesson.

## Useful website

- [www.enchantedlearning.com/Home.html](http://www.enchantedlearning.com/Home.html)  
On the left, scroll down and click *Dinosaurs*

**Search terms:** dinosaurs, extinct animals

## Cross curricular links

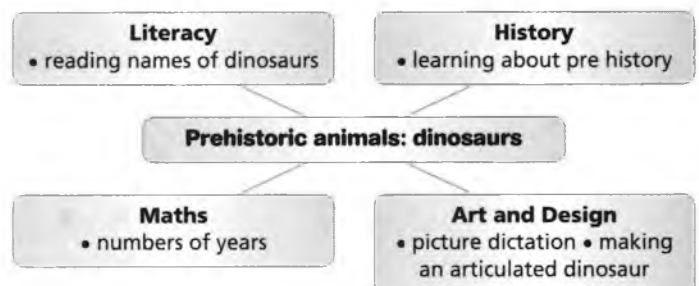

# Prehistoric animals: dinosaurs

## 1 T13 Listen and draw

Cut out the body with skeleton. Draw arms and legs. Put the arms and legs on with split pins.

Tyrannosaurus rex

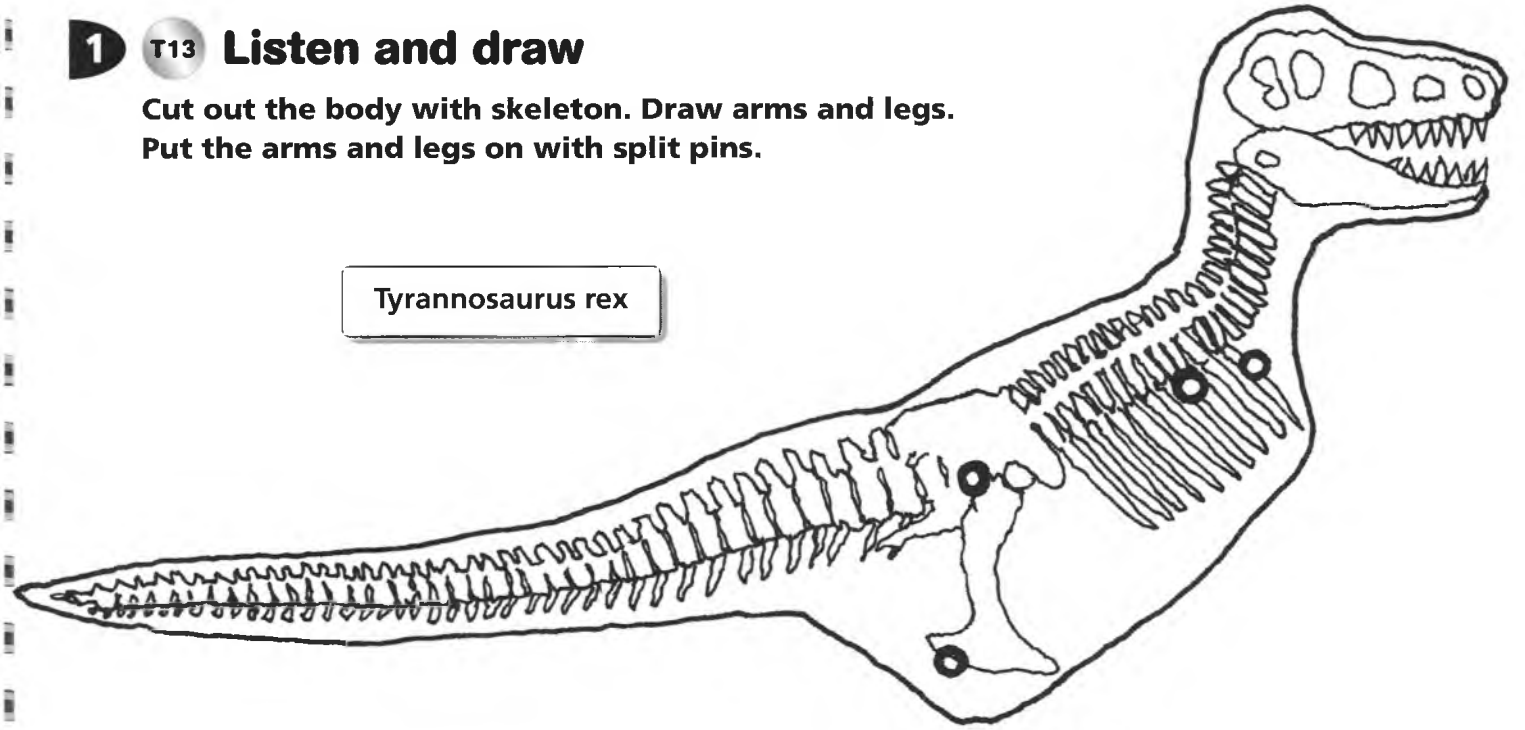

## 2 Help the dinosaurs to find their names in the maze

Which dinosaur reaches its friend first?

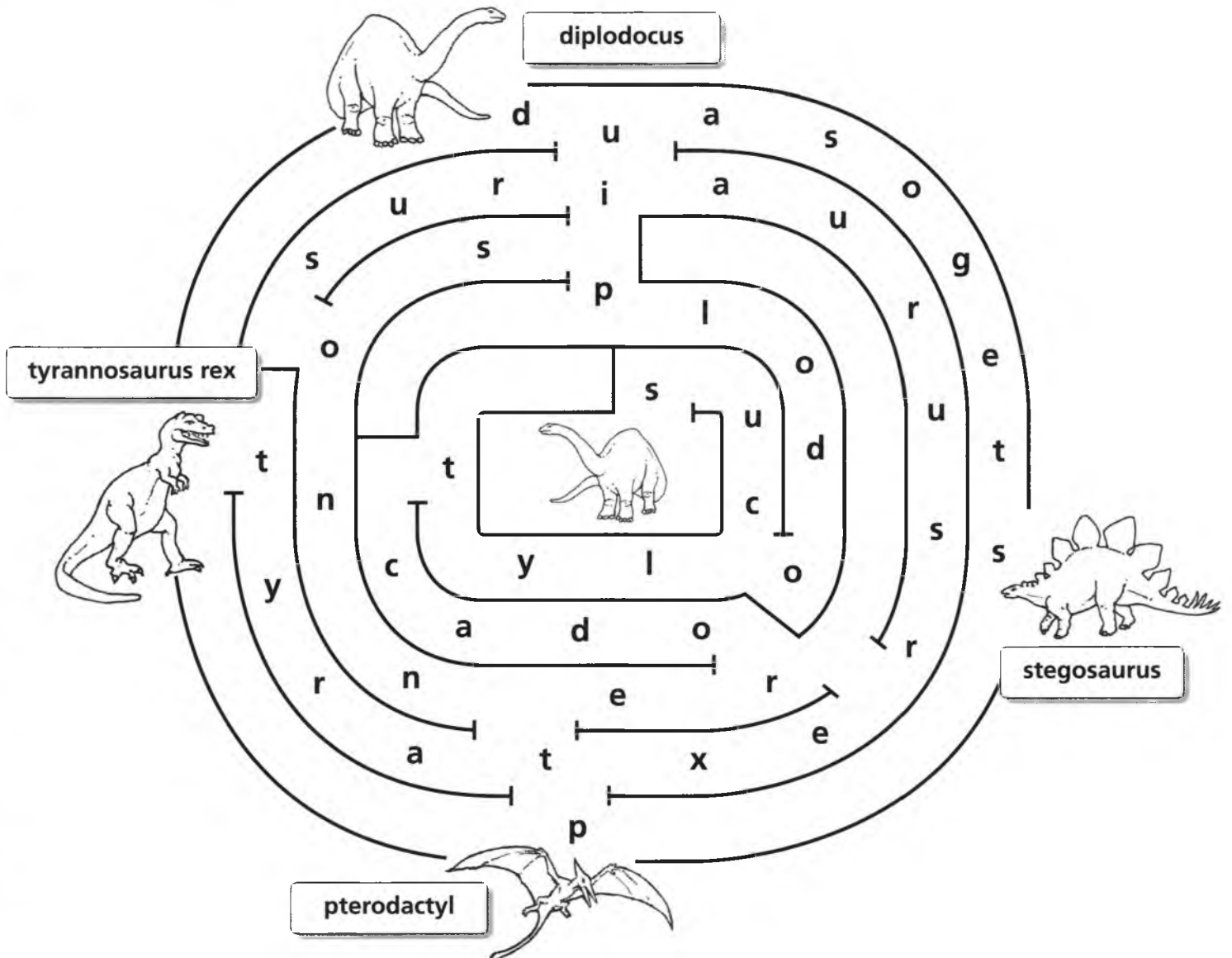

# The life cycle of a bean plant

## Fact box

- Stalk is another word for stem.
- Beans and peas are seeds.
- There are hundreds of kinds of beans, e.g. broad beans, runner beans, mung beans.
- Most bean plants live for just a few weeks or months.

## Aim

- To recognise and understand the life cycle of a bean plant.

## Language

- Sequencing: *first, next, last*
- Vocabulary: *bean, brown, dead, down, flower, green, ground, grow, leaf, leaves, life cycle, plant, pod, root, seed, shoot, soil, stage, stem, up*

## Extra materials

- 1 copy of the Activity page per pupil, Audio Tracks 14 & 15, Audio texts, IWB
- plain paper, scissors, glue sticks, green and brown pencil crayons
- [www.bbc.co.uk/learningzone/clips/](http://www.bbc.co.uk/learningzone/clips/) Type 2260 then click *SEARCH*, then *Plant growth* to watch beans growing

## Warm up

- 1 If possible, watch the science clip of beans growing.
- 2 Display the IWB and complete the activity with the class.
- 3 Give out the Activity sheets. Point to and read the labels. Pupils follow and repeat. Ask when the plant makes new bean seeds.
- 4 Draw a complete bean plant life cycle on the board (see picture 1 on page 51). Explain that it is like a circle: a seed grows into a plant, makes new seeds, seeds grow into new plants. The circle is called a life cycle.
- 5 Read the Audio text for Track 14. Play Audio Track 14. Pupils join in the song and invent hand actions to match the words.

## Procedure

- 1 Give out the plain paper. Play Audio Track 15.
- 2 Pupils listen, repeat and point to the pictures on the Activity sheet. Ask *Which is stage 1?* Pupils point to stage 1.
- 3 Put pupils in pairs. Pupils take turns to ask *Which is the next stage?* and *Which is stage 1/2/3/4/5/6?* and to point. (Make sure pupils understand that the dead plant is stage 6, when new bean seeds fall out of the seed pods.)
- 4 Pupils make a diagram of the life cycle: they colour the pictures green and brown, cut out and glue them in order on the plain paper, cut out and glue the word boxes as labels and draw clockwise arrows.
- 5 Show the class your own completed diagram to check their answers.

## Follow up

- 1 Pupils work in pairs to ask and answer the questions on the sheet, e.g. *What is the first/next/last stage?*
- 2 Repeat the song on Audio Track 14 (with text), *The life of a plant goes round and round*, with actions.

- 3 Grow bean plants in the classroom. Pupils use drawings, photos and measurements to record growth.

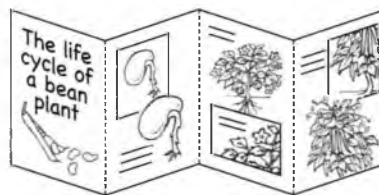

## Useful websites (see also Extra materials above)

- [www.bbc.co.uk/learningzone/clips](http://www.bbc.co.uk/learningzone/clips)  
Type 69 then click *SEARCH*, then *Requirements for healthy plant growth*
- [www.bbc.co.uk/schools/scienceclips](http://www.bbc.co.uk/schools/scienceclips)  
Click *enter*, then *Ages 5-6*, then *Growing plants*
- [www.zephyrus.co.uk](http://www.zephyrus.co.uk)  
Click *Biology*, then *ACTIVITIES*, then *LIFE STORY OF THE BEAN*

**Search term:** life cycle of a bean

## Cross curricular links

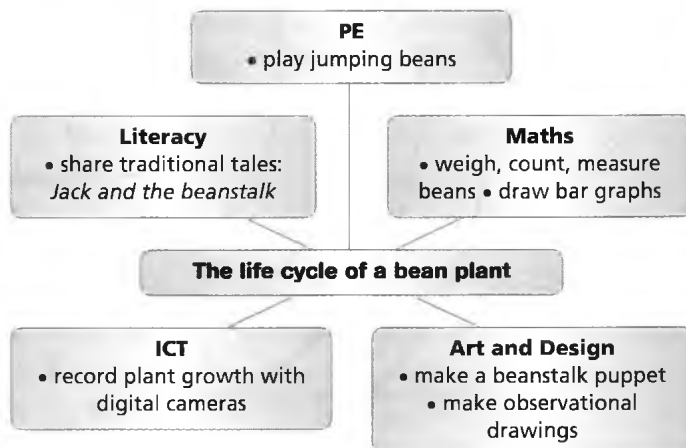

# The life cycle of a bean plant

## 1 T15 Cut, order and label

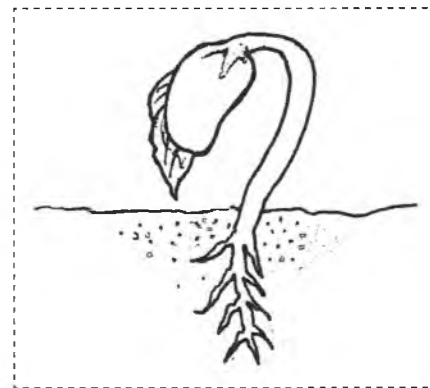
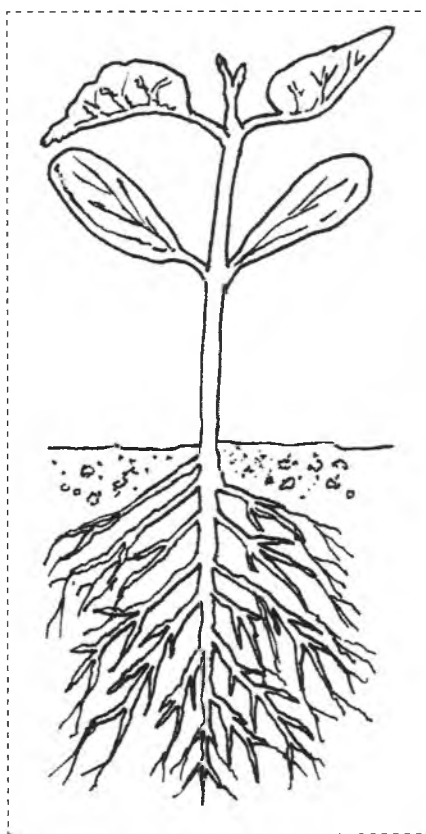
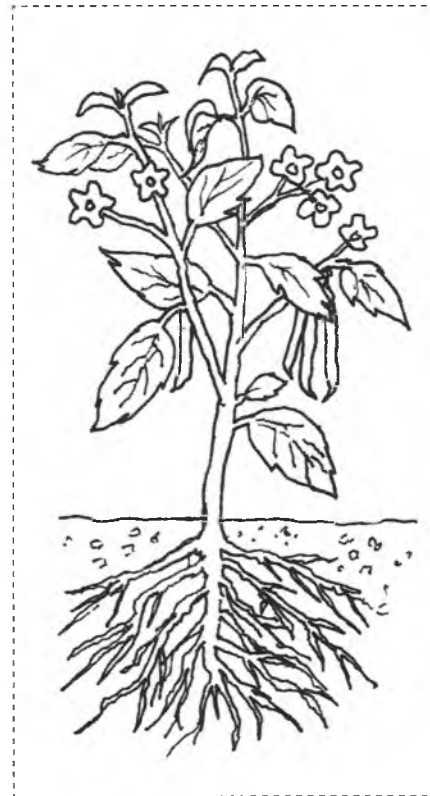
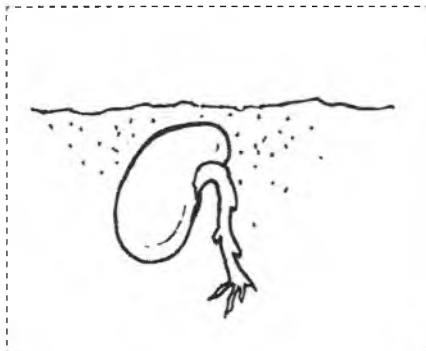

root and shoot

root, stem and leaves

bean

root, stem, leaves,  
flowers and seed pods

root

dead plant with  
new bean seeds

## 2 Ask and answer

Some questions to ask your partner:

- 1 What grows first, the root or the shoot?
- 2 What grows next?
- 3 What grows last, the seed pods or the flowers?
- 4 What does the dead plant look like?

Lesson  
1b

## The life cycles of plants

## Fact box

- Cress, beans and tomatoes sprout very quickly. Their life cycle lasts a few weeks or months.
- A sunflower can have more than 200 seeds.
- Some trees, like oak, yew and olive, can live for hundreds of years.
- Most trees produce seeds each year.

## Aim

- To use knowledge of one plant's life cycle to predict, recognise and understand the life cycle of other plants.

## Language

- Recount text and sequencing
- Vocabulary: *apple, dies, life cycle, pine, pine cone, seedling, seed head, sunflower, tree, trunk*

## Extra materials

- 1 copy of the Activity page per pupil, Audio Track 14 & Audio text, IWB
- pictures of mature apple tree with apples, sunflower plant with seeds and pine tree with cones; coloured pencil crayons; *optional*: sunflower seeds, an apple, a pine cone

## Warm up

- 1 Display the Audio text, play Audio Track 14, and sing the song again with the class.
- 2 Revise the bean plant life cycle: A plant grows from a seed. It grows a root and a shoot. The shoot grows into a stem with leaves and flowers. The flowers make new seeds. Ask: *What happens to the old plant?*
- 3 If you have these available, display the pictures and talk about the sunflower plant, pine tree and apple tree and their seeds.
- 4 If you have them, show the sunflower seeds, apple (cut open to show pips) and pine cone. Introduce the words: *seedling* (a young plant), *trunk* (the stem of a tree), and *pine cone*.

## Procedure

- 1 Hand out the Activity sheets and read the title with the class. Look at picture 1 and revise the bean plant life cycle.
- 2 Ask: *Where is the root/shoot/stem? Which part grows first/next/last?*
- 3 Point to and ask pupils to name the 4 stages: bean seed, seedling with root and shoot, plant with leaves and flowers, plant with seed pods. Write the labels on the board and tell pupils to use them to label diagram 1.
- 4 Read the names of the other plants and discuss which pictures from below are missing from each life cycle.
- 5 Give the pupils 5 to 10 minutes to complete the diagrams on their activity sheets and to label the parts of the plants. Quicker pupils can colour their diagrams.
- 6 Show your own completed Activity sheet for the pupils to check their answers.
- 7 Display the IWB for the pupils to complete the activity.

## Follow up

- 1 Pupils choose a local plant, draw and label its life cycle, then talk to their group or the class about the pictures they have drawn.
- 2 Organise a sunflower-growing competition. Record the heights on a tall, thin wall chart. Use digital photographs to record the stages of growth.
- 3 Collect and grow seeds from apples, tomatoes and other fruit. Use photos to record growth.

## Useful websites

- [www.bbc.co.uk/learningzone/clips](http://www.bbc.co.uk/learningzone/clips)  
Type 69, then *SEARCH*, then *Requirements for healthy plant growth* and/or 71, then *SEARCH*, then *Banana plants – growth and harvesting in Jamaica*

- [www.catie.org.uk/plants\\_galore\\_page.html](http://www.catie.org.uk/plants_galore_page.html)  
For identifying different types of plant

**Search terms:** plant life cycle; growing seeds

## Cross curricular links

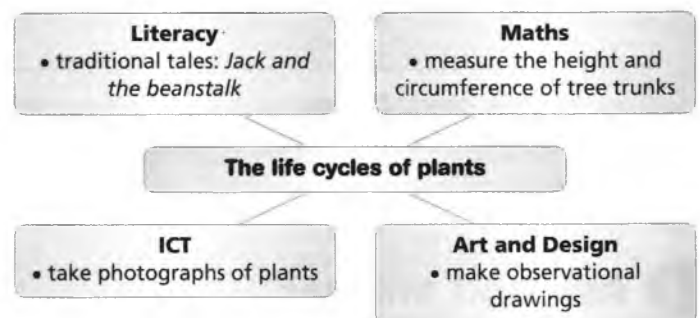

# The life cycles of plants

Draw and label

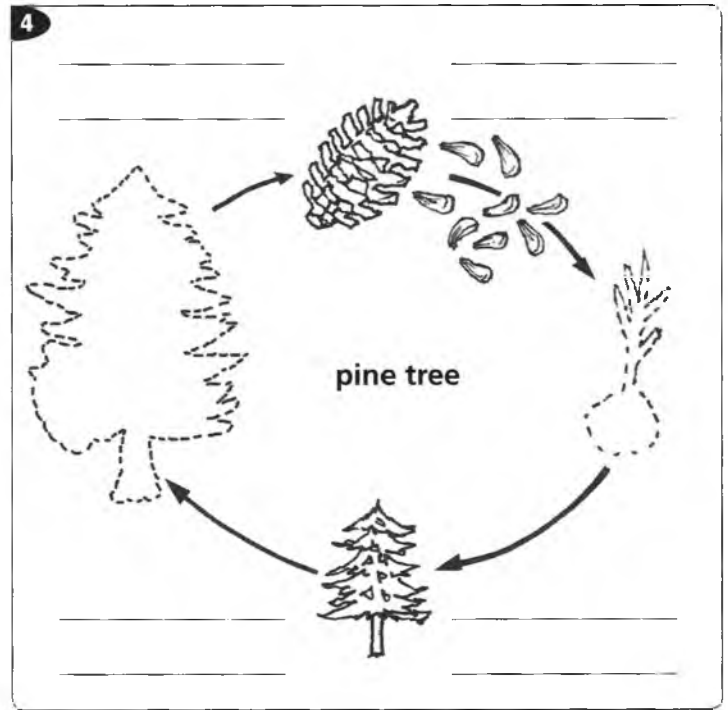
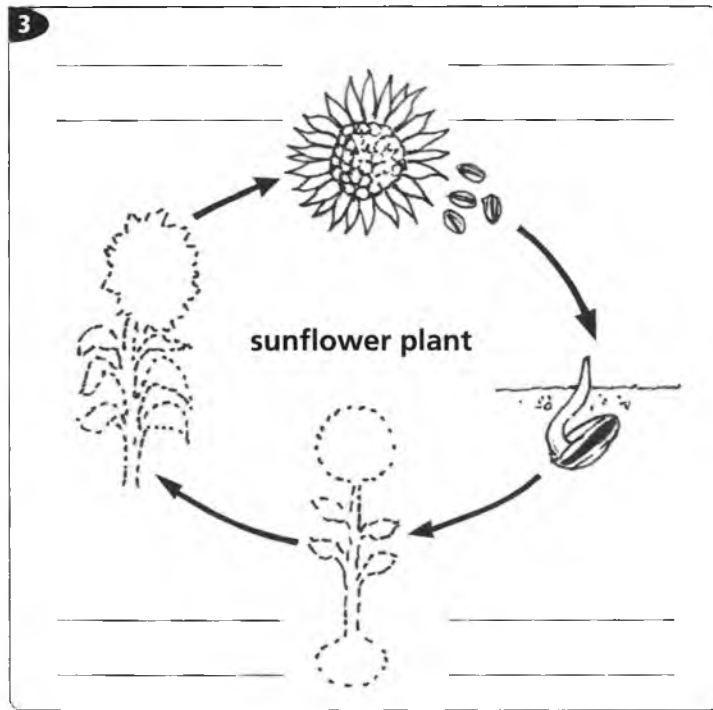
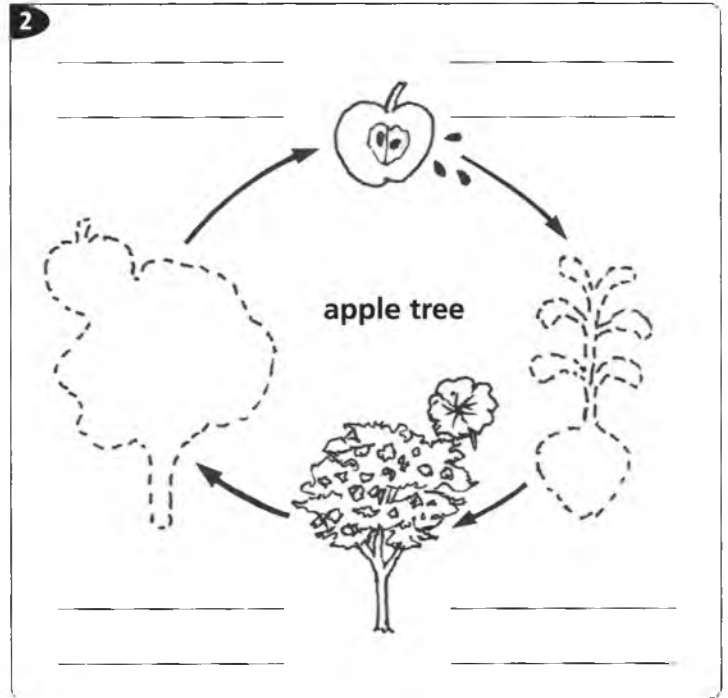
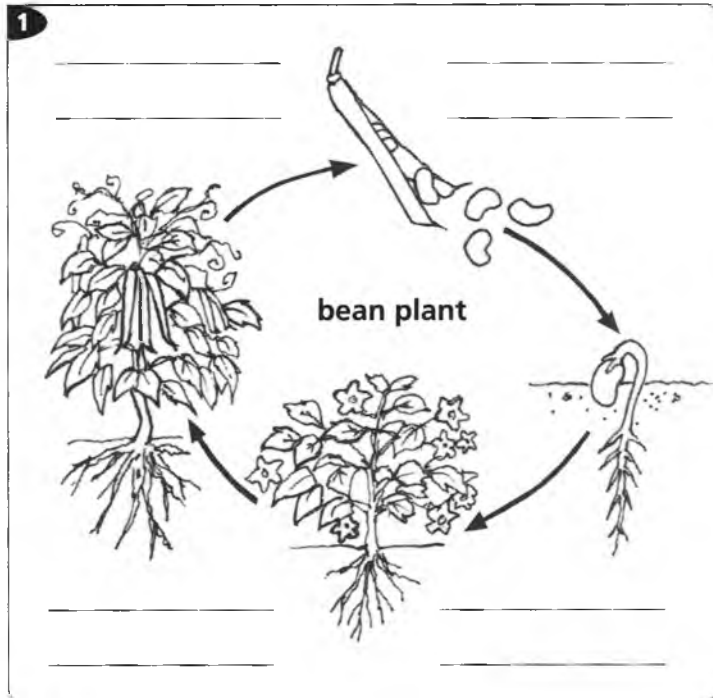

Draw pictures (from below) to complete the life cycles of these plants.  
Label the stages of the life cycles.

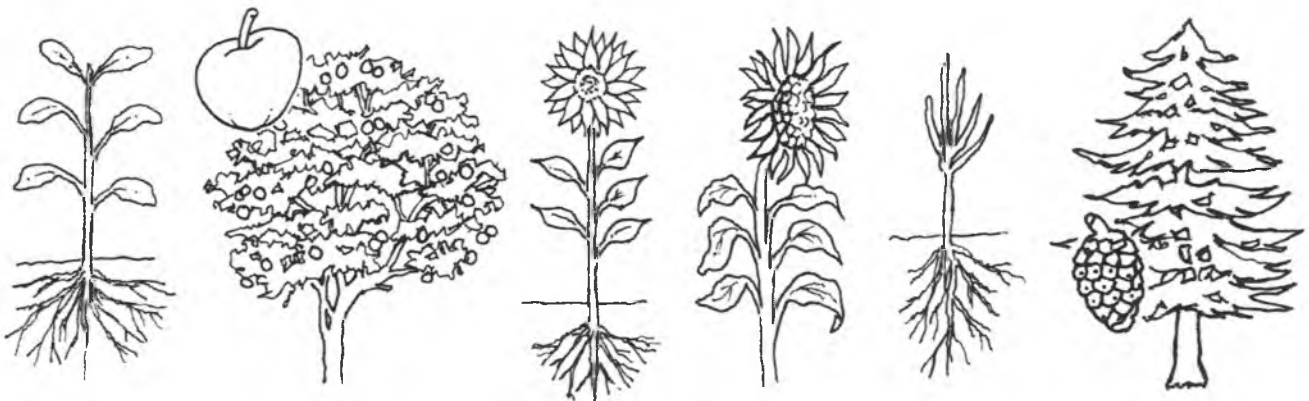

Lesson  
2a

## The life cycle of a frog

## Fact box

- Tadpoles eat insects and smaller tadpoles!
- Frogs eat insects.
- Frogs are amphibians: they live on land and in water.
- Frogs have lungs and cannot breathe underwater.
- Tadpoles have gills, like fish, and can breathe underwater.
- The word *tadpole* means *all head and tail*.

## Aim

- To recognise and understand the stages in the life cycle of a frog.

## Language

- Ordinal numbers: *first, second, third, fourth, fifth*
- Vocabulary: *air, breathe, changes, egg, female, frog, frogspawn, gills, grow, jelly, leg, life cycle, lungs, male, metamorphosis, pond, stages, tadpole, tail, toad, water*

## Extra materials

- [mlbean.byu.edu](http://mlbean.byu.edu) Type *Animal Scramble* into the Search Site, click , click *Animal Scramble*. You will need to prepare the animal cards in advance in order to play the game.
- 1 copy of the Activity page per pupil, Audio Tracks 16 and 17, Audio texts, IWB
- pictures of adult and baby animals, e.g. cow, calf, sheep, lamb, horse, foal, hen, chick, etc; a picture of a frog
- scissors, glue sticks, sticky tape, 1 split pin per pupil, green and brown pencils



## Warm up

- 1 If you have them available, display and discuss the pictures of animals. Introduce the adult and baby pairs, e.g. *horse* and *foal*, *cow* and *calf*.
- 2 Look at the picture of a frog and ask a pupil to draw what they think a baby frog looks like.
- 3 Use the website listed above to display the pictures of adult and baby animals, and then play 'Animal Scramble'.
- 4 Talk about how many young animals look like the adults, but frogs begin life as frogspawn and then change shape. Explain: *These changes are called metamorphosis, from an ancient Greek word meaning change.*
- 5 Display the Audio text and play Audio Track 16. Sing the song with the class.

## Procedure

- 1 Write *first - 1st, second - 2nd, third - 3rd, fourth - 4th* and *fifth - 5th* on the board.
- 2 Discuss the changes from frogspawn to tadpole, to tadpole with back legs then four legs and finally, frog.
- 3 Give out the Activity sheets and play Audio Track 17. Ask the pupils to follow and repeat the words.
- 4 Put pupils into pairs to ask and answer questions about the stages, e.g. *What happens in the third stage?*
- 5 Pupils make a life cycle wheel: cut out all the shapes, glue the 5 life cycle stages onto the numbered circle in the correct order, fasten the circle with cut out on top using a split paper clip in the centre. (*Tips! Safety first: make the hole with a pencil point. Reinforce the back of the hole with sticky tape.*)
- 6 In pairs, pupils take turns to spin the top circle clockwise, point to the picture and ask *What happens next?*
- 7 Display the IWB for the pupils to complete the activity.

## Follow up

- 1 Replay the song and invent actions for it with the class.
- 2 Find out about the frogs and toads in your area.
- 3 Research the main differences between frogs and toads.

## Useful websites (see also Extra materials above)

- [www.bbc.co.uk/learningzone/clips](http://www.bbc.co.uk/learningzone/clips)  
Type *47* then click *SEARCH*, then *Frogs and toads*; type *3010* then click *SEARCH*, then *Can you spot the difference between a frog and a toad?*
- [www.globalclassroom.org](http://www.globalclassroom.org)  
Click *Interactive Resources*, scroll down to *Science*, click *235 The Life Cycle of a Frog*, click *The Life Cycle of a Frog* again
- [www.zephyrus.co.uk/spring3.html](http://www.zephyrus.co.uk/spring3.html)  
Click the frog picture
- [www.oum.ox.ac.uk](http://www.oum.ox.ac.uk)  
Type *frog life cycle* in the search box, click *Go!*, click the first link, scroll down to see the frog life cycle

**Search terms:** frog life cycle, metamorphosis, frogs and toads

## Cross curricular links

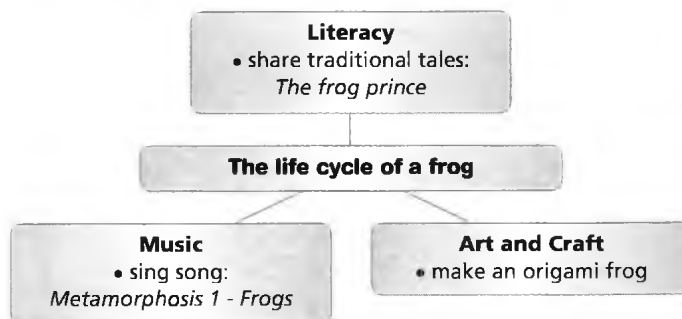

# The life cycle of a frog

T17

## What happens first?

Cut out the pictures and put them in order.

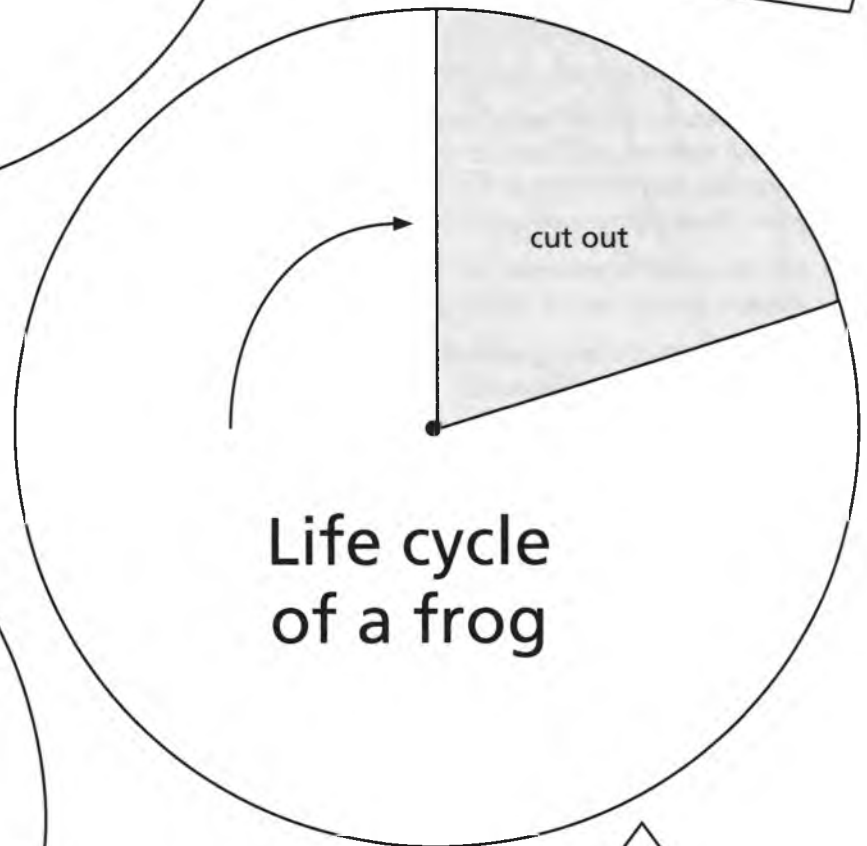
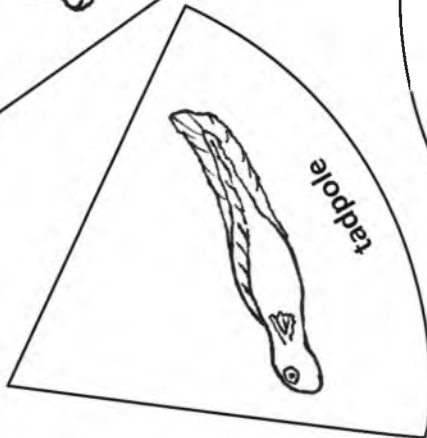
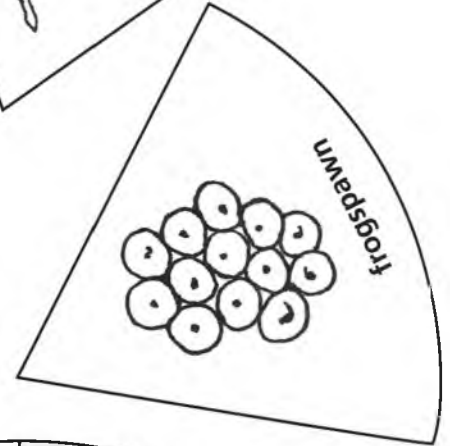
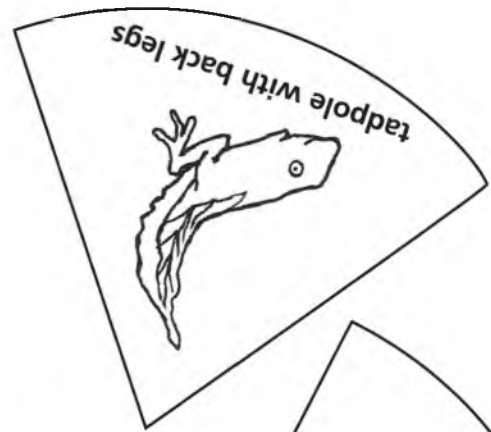
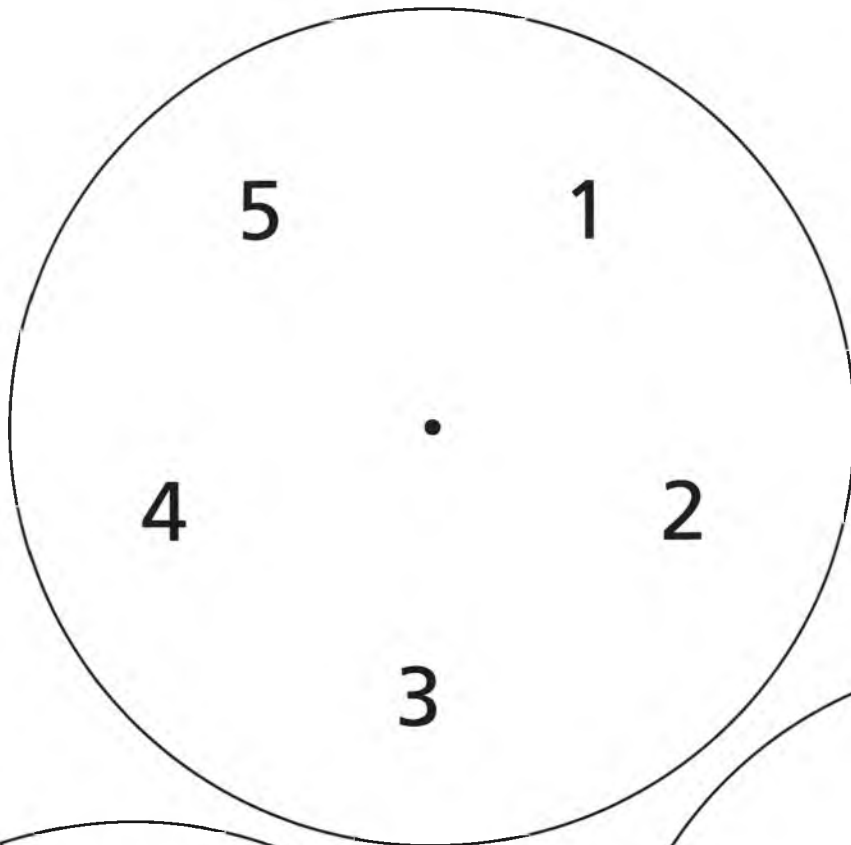

**1st stage:** a frog lays hundreds of eggs. The eggs are called frogspawn.

**2nd stage:** tadpoles hatch out of the eggs; the tadpoles eat and grow bigger.

**3rd stage:** the back legs start to grow and the tail gets shorter.

**4th stage:** the front legs grow.

**5th stage:** the tail has gone and now the tadpole is a small frog.

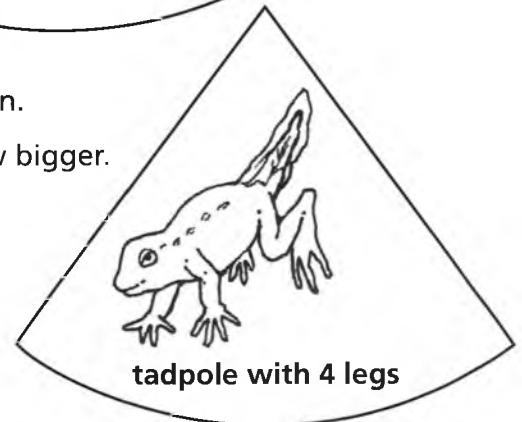

# The life cycle of butterflies and moths

## Fact box

- Butterflies and moths are insects.
- Moths are active at night.
- Butterflies feed on nectar from flowers.
- Caterpillars eat leaves.
- A *chrysalis* is also called a *pupa*.
- Each kind of butterfly lays their eggs on a particular plant.
- Many butterflies hibernate in winter but some migrate.

## Aim

- To recognise and understand the stages of the life cycle of butterflies and moths.

## Language

- Temporal connectives: *next, then, finally*
- Vocabulary: *butterfly, caterpillar, chrysalis, cocoon, leaf, metamorphosis, moth, silk, spins*

## Extra materials

- [mlbean.byu.edu](http://mlbean.byu.edu) Type *Animal Scramble* into the Search Site, click 🔍, click *Animal Scramble*. You will need to prepare the animal cards in advance in order to play the game.
- [www.bbc.co.uk/learningzone/clips](http://www.bbc.co.uk/learningzone/clips) Type *8995*, then click *SEARCH*, then *Caterpillar metamorphosis*
- 1 copy of the Activity page per pupil, Audio Tracks 18 & 19, Audio texts, IWB
- plain paper, scissors, glue sticks, coloured pencils

## Warm up

- 1 Use the website listed above to display the pictures of adult and baby animals, and then play 'Animal Scramble'.
- 2 Write *metamorphosis* on the board. Explain: *Most animals look like their parents when they are born but some look very different and change shape as they grow. These changes are called metamorphosis.*
- 3 Ask the pupils for examples of animals that change shape as they grow, e.g. the frog (see Lesson 4.2a).
- 4 Display the Audio text, play Audio Track 18 and sing the first verse of *Metamorphosis II*.
- 5 Introduce the words *butterfly* and *moth*. Explain: we see butterflies in the day but most moths fly at night.
- 6 Now use Audio Track 18 and the Audio text to play and sing all of *Metamorphosis II*.

## Procedure

- 1 Hand out the Activity sheets and read the text or play Audio Track 19. Pause for pupils to repeat the words.
- 2 Write *first, next, then* and *finally* on the board.
- 3 Talk about the four stages of a butterfly's life.
- 4 Put the pupils in pairs to ask and answer questions, e.g. *What happens first/next/finally?*
- 5 Give out the plain paper, scissors, glue sticks and coloured pencils.
- 6 Allow 10 minutes for the pupils to colour, cut out and match the pictures and sentences, then glue them onto plain paper in the correct order.
- 7 Display the IWB for the pupils to complete the activity.

## Follow up

- 1 Invent actions to go with the song, *Metamorphosis II*, and sing it again, with actions.
- 2 Make a poster about the life cycle of a local moth or butterfly.
- 3 Find out how butterflies and moths are different from each other.

## Useful websites (see also Extra materials above)

- [www.bbc.co.uk/learningzone/clips](http://www.bbc.co.uk/learningzone/clips)  
Type *7768*, then click *SEARCH*, then *A song about a tiny caterpillar*
- [www.butterfly-guide.co.uk](http://www.butterfly-guide.co.uk)  
Click *Life-Cycle* below *Contents*

**Search terms:** butterfly life cycle, metamorphosis, butterflies + moths

## Cross curricular links

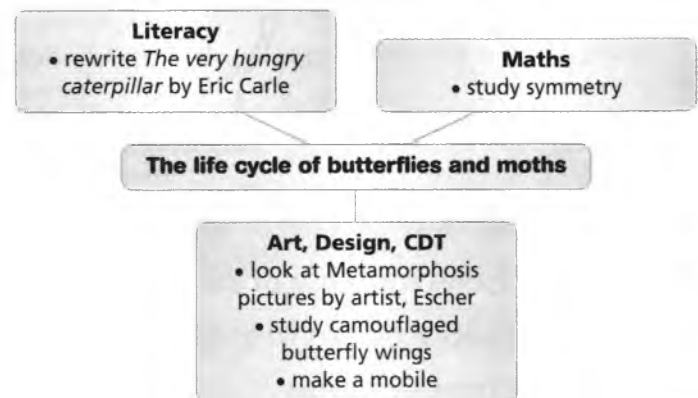

# The life cycle of butterflies and moths

**T19** There are four stages in the life cycle of a butterfly and a moth

Stage 1: A butterfly or moth lays some eggs on a leaf.

Stage 2: A caterpillar hatches from an egg. It eats and grows.

Stage 3: The caterpillar spins a cocoon of silk and changes into a chrysalis.

Stage 4: A butterfly or moth comes out of the chrysalis.

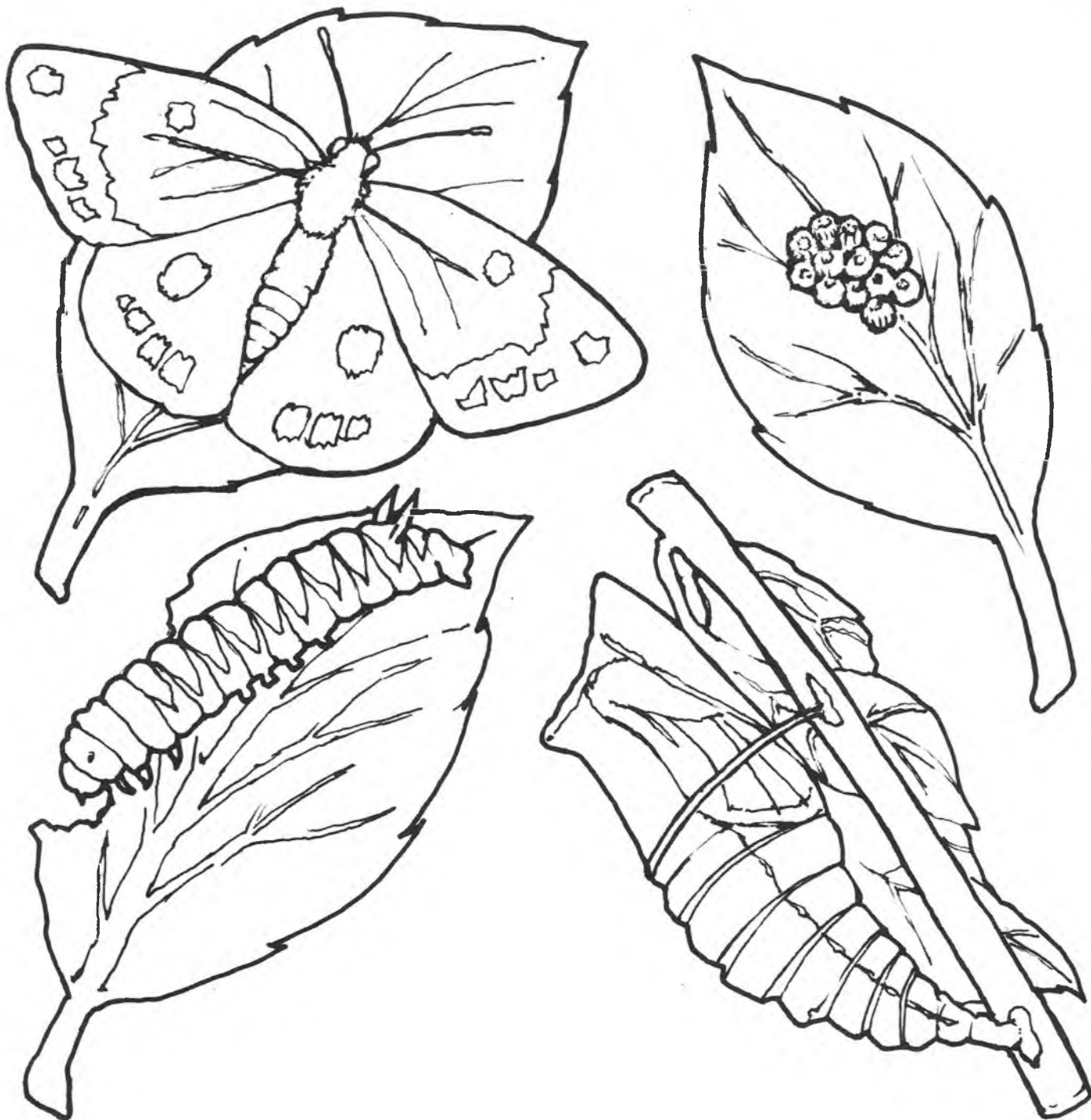

Colour, cut out and match the pictures and sentences, then put them in order.

# Life cycles in changing habitats

## Fact box

- Wild bison nearly became extinct and are now protected.
- Bison can live for 20 to 25 years.
- Wild polar bears can live for about 25 years.
- Arctic terns can live up to 34 years.
- Arctic terns fly up to a million kilometres in a lifetime.
- To *hibernate* means to *hide away and sleep or to be inactive in winter*.

## Aim

- To identify ways in which animal life cycles are adapted to changing habitats.

## Language

- Exploring information texts
- Vocabulary: *Arctic tern, bison, habitat, hibernate, life cycle, migrate, migration, nest, nestling, polar bear, season, shelter, underground*

## Extra materials

- 1 copy of the Activity page per pupil, Audio Tracks 20 – 22, IWB
- [www.scholastic.com/magicschoolbus](http://www.scholastic.com/magicschoolbus) Hover over *Games*, click *Games*, go to page 4 then scroll down and click *The Great Habitat Match*

## Warm up

- 1 Ask pupils to name the seasons. Write *spring, summer, autumn, winter, wild animals, habitat* on the board.
- 2 Explain: *A habitat is the place where an animal lives, finds food and shelter and has young.*
- 3 Go to the website above and follow the links to play a game, matching animals with their habitats.
- 4 Explain that many habitats change as the seasons change and most animals match their life cycles to these changes. Ask why birds lay their eggs in the spring.

## Procedure

- 1 Hand out the Activity sheets and focus on the photo of the Arctic tern with young. Explain: *Some birds travel thousands of kilometres to lay eggs in a good habitat.*
- 2 Play Audio Track 20/Read the text. Pupils listen and follow on their Activity sheet. Ask when the life cycle of an Arctic tern begins. Write *migrate* and *migration* on the board. Ask when Arctic terns migrate.
- 3 Focus on the picture of the bison and play Audio Track 21/read the text. Pupils listen and follow on their Activity sheet. Ask what happens at the end of migration.
- 4 Focus on the polar bear and play Audio Track 22/read the text. Ask where polar bears live, if they migrate and how their life cycle matches the seasons.
- 5 Write the Fact box information on the board and read through it with the class.
- 6 Display the IWB for the pupils to complete Tasks 1 to 3.
- 7 Allow 15 minutes for the pupils to work individually, in pairs or groups to complete the table using information from the Activity sheet and the Fact box. Check the answers with the class.

## Follow up

- 1 Pupils compare and discuss their answers in groups and then report their findings to the class.
- 2 Make a zigzag book about an animal, e.g. a swallow, penguin or whale, comparing the stages of its life cycle to the changing weather during each season.

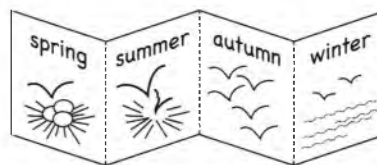

## Useful websites (see also Extra materials above)

- [www.bbc.co.uk/learningzone/clips](http://www.bbc.co.uk/learningzone/clips)  
Type 5502, click *SEARCH*, then *Polar bears must adapt to melting ice caps*
- [www.rspb.org.uk/youth/learn](http://www.rspb.org.uk/youth/learn)  
Click *Migration*
- [www.abc.net.au/schoolstv/animals](http://www.abc.net.au/schoolstv/animals)  
Click *In the air* to learn about Australian animals' habitats

**Search terms:** migration, hibernation, habitat

## Cross curricular links

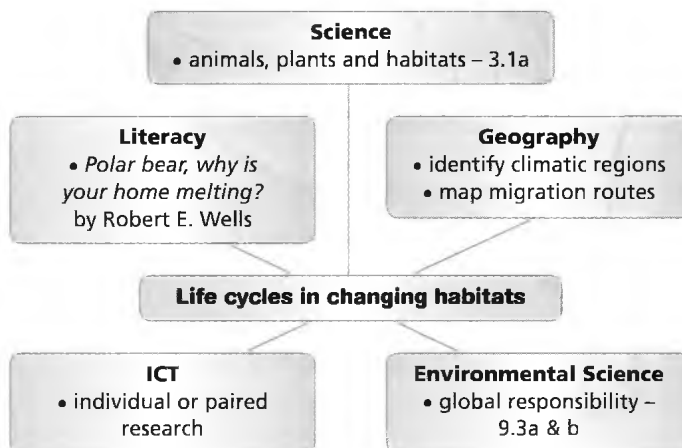

# Life cycles in changing habitats

## T20 Arctic terns

Arctic terns are seabirds. In May and June Arctic terns nest on the ground in the Arctic. They feed their chicks on sand eels, small fish and insects. In September, when the young birds have grown and winter is coming, they begin to fly south. When they reach the Antarctic the southern summer has begun. The birds fish in the sea but they do not land on the snow and ice. In March, when it begins to grow colder and darker, they migrate north again. Arctic terns fly more than 35,000 kilometres every year to match their life cycle to the changing seasons.



## T21 Bison

Wild bison live in the grasslands of North America. In the spring they migrate hundreds of kilometres northwards to places such as Yosemite, where there has been thick snow all winter. Most calves are born in grassy meadows at the end of the migration. When the calves have grown and there is little grass left, the herds migrate southwards before the snow falls again.

## T22 Polar bears

Polar bears live in the Arctic where it is very cold and snowy. Winter lasts for six months and it is dark all the time. The bears have thick fur to keep them warm. Female bears hibernate in winter. They dig dens in the snow where it is warmer. Their cubs are born in the dens and grow up in a safe place, away from male bears which might kill and eat them. They leave the den in the spring when their mothers go out to catch fish and seals.



	Polar bears	Arctic terns	Bison
Where do they live?			
What do they eat?			
When are they born?			
Where are they born?			in a meadow
What are the young called?		chicks	
How long do they live?			
Do they hibernate?			
Do they migrate?	no		
One more fact			

Lesson  
3b

# What happens when a habitat is changed?

**Fact box**

- An environment contains many habitats, e.g. tree, pond, grass.
- Most young are born when the weather is good and food is easy to find.
- Droughts, floods and low temperatures cause natural changes to habitats.
- Man's activities – building, logging, fires, oil spills, pollution – change habitats. Many animals cannot adapt quickly to these changes.
- Sparrows live for 2 to 3 years.

**Aims**

- To recognise the way life cycles are affected by environmental changes.
- To understand the difference between fact and opinion.

**Language**

- Persuasive texts; Letter writing; Conditional: *could, would*
- Vocabulary: *affect, bird, car park, environment, fact, newspaper, opinion, persuade*

**Extra materials**

- 1 copy of the Activity page per pupil, Audio Tracks 23 – 26, Audio texts, IWB

**Warm up**

- 1 Write *habitat* on the board. Ask for definitions.
- 2 Display Audio text for Track 23, play Audio Track 23 and ask pupils to listen and follow. Discuss with the class. (Possible answers: polar bear, penguin, seal.)
- 3 Discuss what could happen to the life cycle if there was no snow.
- 4 Display Audio text for Track 24, play Audio Track 24 and ask pupils to listen and follow. Discuss with the class. (Possible answers: bison, rabbit, kangaroo.)
- 5 Ask and discuss: *What could happen if the habitat changed and there was no rain, or a town was built?*
- 6 Ask why most birds live in trees and why they lay their eggs in the spring.

**Procedure**

- 1 Hand out the Activity sheets. Play Audio Track 25. Pupils listen and follow. Ask what is going to happen.
- 2 Play Audio Track 26. Pupils listen and follow. Ask what Tom and Anna want to happen.
- 3 Write on the board: *Tom and Anna want to persuade people to keep the park for the birds.* Explain *persuade*. List examples of Tom and Anna's ideas from the letter.
- 4 Allow pupils 5 minutes to underline the persuasive words and phrases and to copy them into the table.
- 5 Write *fact* and *opinion* on the board. Explain the difference between facts and opinions.
- 6 Replay/Reread the newspaper article and letter and ask the pupils for examples of facts and opinions.
- 7 Display the IWB for the pupils to complete the activity.
- 8 Allow 5 to 10 minutes for the pupils to complete the table.

**Follow up**

- 1 Discuss how Tom and Anna's letter could be improved.
- 2 Write a short persuasive letter or a blog page asking for action to save the habitat of an endangered animal.
- 3 Find out about environmental projects in your area.

**Useful websites**

- [www.sparrowcam.com](http://www.sparrowcam.com)  
Click *SparrowCam Videos*
- [www.bbc.co.uk/learningzone/clips](http://www.bbc.co.uk/learningzone/clips)  
Type 7544, 7521, 2309 or 8987 then click *SEARCH* to watch birds/animals in their habitats
- [www.bbc.co.uk/schools/scienceclips/ages/6\\_7/plants\\_animals\\_env.shtml](http://www.bbc.co.uk/schools/scienceclips/ages/6_7/plants_animals_env.shtml)
- [www.rspb.org.uk/youth](http://www.rspb.org.uk/youth)  
Click on *PLAY*, on *DISCOVER* and/or on *LEARN*
- [www.bbc.co.uk/schools/ks2bitesize/english/writing](http://www.bbc.co.uk/schools/ks2bitesize/english/writing)  
Use the activities at *Argument*

**Search terms:** birds + habitats, conservation

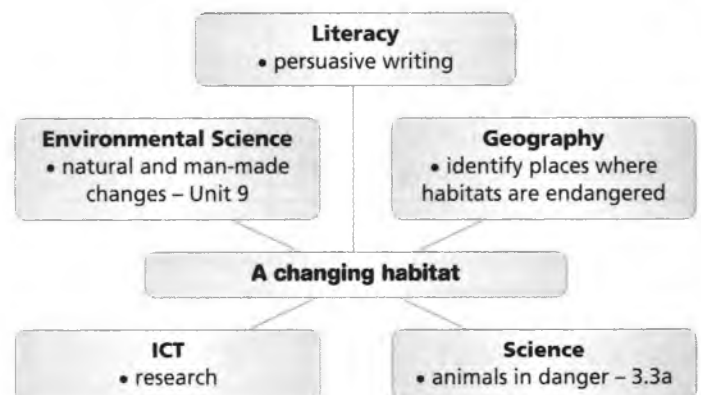
**Cross curricular links**

# What happens when a habitat is changed?

## Read the newspaper



T25

## The End of the Old Park

This is your last chance to go to the Old Park. Next week the Old Park will be turned into a car park. The beautiful 100-year-old trees will be cut down. The grass and flower beds will be dug up. In two weeks' time there will be space for 50 cars to park but there will be no green space for people, birds and animals to enjoy.

T26 Dear Readers,

We think it is a bad thing that the Old Park is going to be made into a car park. We think it should be stopped. We would like the park to stay as it is now, because so many birds live there. It is a good habitat for them in the spring.

If we must have a new car park why do the trees have to be cut down so soon? Many birds have nests in those trees. Many



eggs have hatched and the baby birds need to eat the caterpillars that are on the flower beds now. It is too late for them to start their life cycle again in another

place. Many small birds only live two years so next year there will be no new adults to lay eggs. We shall miss having the birds around.

If the park must be destroyed please, please, please help us to find a way to keep the trees and flowers for a few more weeks until this year's baby birds can leave the nest.

Yours faithfully,  
Tom and Anna

Write some of the persuasive words and phrases from the letter here:

Reread the newspaper article and the letter and write 2 facts and 2 opinions here:

Fact
Fact
Opinion
Opinion

Lesson  
1a

# Can I change these shapes?

**Fact box**

- Stone, wood, wool and clay are natural materials.
- Metal is mined and manufactured.
- Plastic is made from oil.
- Paper is made from wood pulp.
- Energy – force or heat – is needed to make changes.

**Aim**

- To understand that the shape of some objects can be changed because of the properties of their materials.

**Language**

- Recording results on a table
- Verbs: *bend, change, predict, pull, push, shake, snap, squeeze, twist*
- Vocabulary: *clay, foil, hard, material, metal, nothing, paper, plastic, shape, soft, stone, wool*

**Extra materials**

- 1 copy of the Activity page per pupil, Audio Track 27, Audio text, IWB
- per pair: a selection of materials to test: soft clay/dough, metal (paper clip/coin), foil, paper, plastic (bag/bottle), stone, wood, wool (thread/cloth); a coin, coloured pencils, poster paper

**Warm up**

- 1 Write this list on the board: *metal, plastic, wood, paper, clay, stone, wool*.
- 2 Show a selection of objects and ask the pupils to match each to one or more of the materials.
- 3 Use hand actions to teach *bend, pull, push, shake, snap, squeeze, twist*.
- 4 Ask pupils if they can change the shape of any materials by bending, pulling, squeezing or twisting them.
- 5 Display the Audio text and play Audio Track 27. Pupils listen and follow the words, then sing with actions.

**Procedure**

- 1 Display a lump of clay/dough. Ask *Is it hard or soft? Will it twist or bend? If I pull it hard will it snap?*
- 2 Repeat for wood, paper, metal and plastic. Ask pupils to predict what will happen before testing each time.
- 3 Hand out the Activity sheets. Put the pupils in pairs and give each pair a selection of materials and a coin.
- 4 Explain the board game: Take turns to spin the coin and move 1 (heads) or 2 (tails) places. Read the instruction aloud then test the material. If it changes shape, write *yes* in the results box; if not, write *no*.
- 5 Allow 10 to 15 minutes to play the game and record the test results.
- 6 Tell pupils to colour the boxes on the board game red if the material changes, blue if it does not and green if the shape changes and then changes back again.
- 7 Ask which materials changed shape and which did not.

**Follow up**

- 1 Ask pupils to predict the results of any tests that were not done and then make the tests.
- 2 Discuss why you can change the shape of metal foil but not of a metal coin.
- 3 Display the IWB for the pupils to complete the materials word search. Explain that pupils will get a higher score if they highlight each answer correctly first time.
- 4 Put pupils into groups to make posters illustrating the different things made from one kind of material.
- 5 Play AudioTrack 27, display the Audio text and sing the action song again.

**Useful websites**

- [www.bbc.co.uk/schools/scienceclips](http://www.bbc.co.uk/schools/scienceclips)  
Click *enter*, then *Ages 5-6*, then *Sorting and using materials* and/or *Ages 6-7*, then *Grouping and changing materials*
- [www.bbc.co.uk/learningzone/clips](http://www.bbc.co.uk/learningzone/clips)  
Type *2489, 2491* or *2485*, then click *SEARCH* to watch different clips
- [www.mape.org.uk/activities/sorting\\_games](http://www.mape.org.uk/activities/sorting_games)  
Click on *Science*

**Search terms:** materials + properties

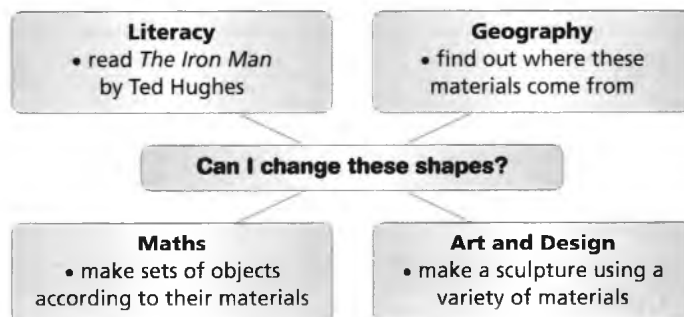
**Cross curricular links**

# Can I change these shapes?

## Materials game

Take turns to spin a coin. Move 1 (heads) or 2 (tails) spaces. Follow the instruction. Does the material change shape? Write *yes* or *no* in the results box.

<b>1</b> squeeze wood	<b>2</b> pull metal	<b>3</b> bend paper	<b>4</b> twist clay	<b>5</b> twist plastic
<b>10</b> pull foil	<b>9</b> bend wood	<b>8</b> squeeze metal	<b>7</b> twist paper	<b>6</b> bend clay
<b>11</b> pull paper	<b>12</b> bend foil	<b>13</b> twist wood	<b>14</b> bend plastic	<b>15</b> bend wool
<b>20</b> squeeze clay	<b>19</b> pull plastic	<b>18</b> squeeze paper	<b>17</b> pull wood	<b>16</b> twist stone
<b>21</b> pull wool	<b>22</b> pull clay	<b>23</b> bend stone	<b>24</b> squeeze wool	<b>25</b> twist foil

Material	squeeze	bend	twist	pull
wood				
foil				
clay				
stone				
plastic				
wool				
paper				
metal				

Lesson  
1b

## Fair tests for change

## Fact box

- Materials can be solid, liquid or gas.
- Materials change when they are heated or cooled.
- Sometimes the materials are changed for ever.

## Aims

- To understand the meaning of a fair test.
- To be able to predict the results of a fair test to change everyday materials by heating.

## Language

- Numbered instructions
- Fair test method results table
- Vocabulary: *bread, burn, camera, change, chocolate, fire, heat, ice cream, material, melt, metal, oven, paper, photograph, steam, stone, toast, tray, water*

## Extra materials

- 1 copy of the Activity page per pupil, Audio Tracks 28 & 29, Audio texts, IWB
- chocolate, bread, paper, stone

## Warm up

- 1 Display the Audio text for Track 28. Play Audio Track 28 and read the chant with the pupils.
- 2 Explain that a fair test is one where *only one thing* is changed and then tested, and everything must be tested in the same way.
- 3 Play and say the chant again. Put the class in 2 groups or choose 2 pupils to play the parts of the testers.
- 4 Display the IWB for the pupils to complete the rhymes.

## Procedure

- 1 Give out the Activity sheets and point to the oven. Ask *What happens if you put ice cream in a hot oven?* (It melts; it changes shape.) Ask *What happens if you put bread in a hot oven?* Discuss how some things go soft, but other things go hard.
- 2 Play Audio Track 29 and ask the pupils to listen and follow the words on the Activity sheet.
- 3 Discuss whether this is a fair test. Ask *Is it a fair test? Is everything the same? Are all the materials heated for the same length of time? What are the trays made of? What temperature is the oven?*
- 4 Ask the pupils to predict what will have happened to each of the materials after five minutes in the oven.
- 5 Explain how to fill in the results table and the picture boxes.

## Follow up

- 1 Ask which materials stayed the same and which changed shape. Ask if their predictions were correct.
- 2 Talk about other materials that could be tested in this way.
- 3 Carry out and record a practical fair test to find the effects of cooling using a freezer or refrigerator.

## Useful websites

- [www.bbc.co.uk/learningzone/clips](http://www.bbc.co.uk/learningzone/clips)  
Type 2464, 2167, 2296, 2493 and click *SEARCH* each time to watch 4 clips about changing materials
- [www.schoolsworld.tv/node/1325](http://www.schoolsworld.tv/node/1325)  
Watch the clip to see how stuff changes
- [www.bbc.co.uk/schools/ks2bitesize](http://www.bbc.co.uk/schools/ks2bitesize)  
Click on *Science*, then *Materials*
- [www.fossweb.com](http://www.fossweb.com)  
Click *Grades K-2*, then *Solids and Liquids*, then *Change It!*

**Search terms:** materials + state, fair test, solid, liquid, gas

## Cross curricular links

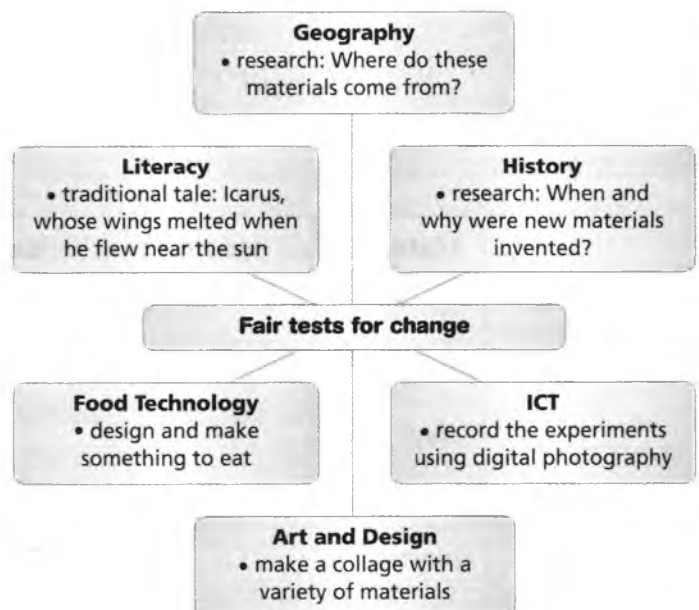

# Fair tests for change

## A fair test to find out how some everyday materials change when heated

T29

### Equipment

oven set at 100°C    chocolate  
6 metal trays        water  
5-minute timer       bread  
camera                paper  
                             stone

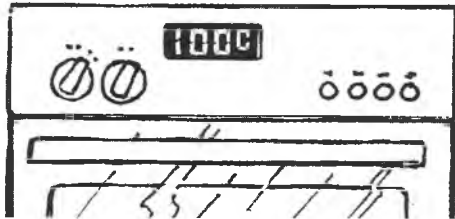

### Method

- 1 Heat the oven to 100 degrees C.
- 2 Put the chocolate, bread, stone, paper and water on the trays.
- 3 Leave one tray empty.
- 4 Take a photograph of each tray.
- 5 Put all the trays in the oven for 5 minutes.
- 6 Take out the trays and photograph each one.

### Results

*The paper was on fire! The results table and photographs were burnt!*

1 Fill in this new table. Write how you think the materials changed.

Material	Before heating	After heating
metal (tray)		
chocolate		
bread		
water		
paper		
stone		

2 Draw 6 pairs of pictures to show the changes.

metal		chocolate		bread	
before	after	before	after	before	after
water		paper		stone	
before	after	before	after	before	after

Lesson  
2a

## Will it dissolve in water?

## Fact box

- **To dissolve:** to mix with a liquid to make a solution.
- **Solution:** a liquid with a solid, liquid or gas dissolved in it.
- A solution can often be separated by heating.
- **Soluble:** a soluble substance is one that will dissolve.
- **Insoluble:** an insoluble substance will not dissolve.

## Aim

- To understand that some substances dissolve in water while others do not.

## Language

- Vocabulary: *beaker, dissolve, flour, insoluble, liquid, mix, mixture, salt, sand, soluble, solution, spoon, substance, sugar, water*

## Extra materials

- 1 copy of the Activity page per pupil, Audio Tracks 30 – 32, Audio texts, IWB
- red and blue pencils, 2 transparent plastic beakers, salt, sand, water, spoon

## Warm up

- 1 Demonstrate the difference between insoluble and soluble substances by stirring a spoonful of sand into water in a beaker, and then a spoonful of salt into water in a beaker.
- 2 Play Audio Track 30, or read these sentences. Pause after each question for pupils to answer:
  - A. *What happens if I put sand into water?*  
*Can you see the sand?*  
*Is it still there?*  
*This is now a **mixture** of sand and water.*
  - B. *What happens if I put salt into water?*  
*Can you see the salt?*  
*Is it still there?*  
*The salt is still there but you cannot see it.*  
*It is a **solution** of salt and water.*  
*The salt has **dissolved** in the water.*
- 3 Display the Audio text and play Audio Track 31. Let the pupils listen and follow the words first, then play the song again for the pupils to join in.

## Procedure

- 1 Hand out the Activity sheets. Tell the pupils to look at the Information box in activity 1. Play Audio Track 32 or read the text in the box to the class. Ask the pupils to listen and follow the words.
- 2 Ask different pupils to reread the sentences to the class.
- 3 Display the IWB for the pupils to complete the activity.
- 2 Explain that in activities 2 and 3, pupils must predict whether some substances are soluble or not.
- 5 Allow 5 minutes for activity 2, then check the answers with the class.
- 6 Explain how to move along the letters in a clockwise direction (like the arrow) to find the words for activity 3.
- 7 Allow 5 to 10 minutes for the pupils to complete the activity, then check the answers with the class.

## Follow up

- 1 Make tests on some or all of the substances named in the lesson to test the pupils' predictions of solubility.
- 2 Ask pupils for the meanings of the scientific words: *dissolve, solution, soluble, and insoluble.*
- 3 Design and carry out experiments to find out: if sugar will dissolve in milk or other liquids; if solutions can be made with other liquids.

## Useful websites

- [www.bbc.co.uk/schools/teachers/keystage\\_2/activities/science4.shtml](http://www.bbc.co.uk/schools/teachers/keystage_2/activities/science4.shtml)  
Scroll down and click on *Different changes*
- [www.bbc.co.uk/learningzone/clips/](http://www.bbc.co.uk/learningzone/clips/)  
Type 2287 then click *SEARCH*; type 2295 then click *SEARCH*; type 8455 then click *SEARCH* and watch the clip each time
- [www.primaryresources.co.uk/science](http://www.primaryresources.co.uk/science)  
Under *Sc3*, click on *Changing materials*, then select *PDF* after *Dissolving Experiment*
- [www.cwmbachjunior.co.uk/6d-dissolving.shtml](http://www.cwmbachjunior.co.uk/6d-dissolving.shtml)

**Search terms:** soluble + insoluble, Why the sea is salt + story

## Cross curricular links

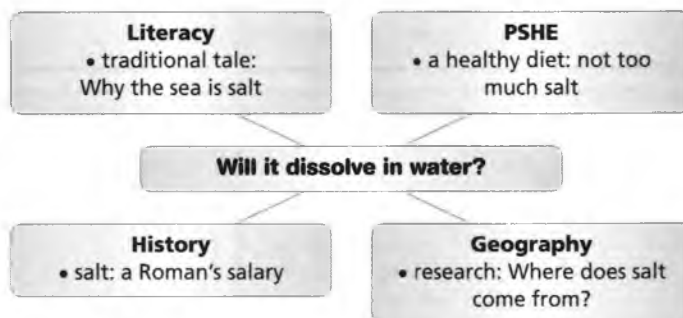

# Will it dissolve in water?

## 1 T32 Solutions

### Information box

- Some substances *dissolve* when you mix them with water.
- *Soluble* substances dissolve. You cannot see the substance but it is still there. The new liquid is called a *solution*.
- Substances that do not dissolve are *insoluble*.

## 2 Which substances will dissolve in water?

Write *soluble* or *insoluble* below each picture.

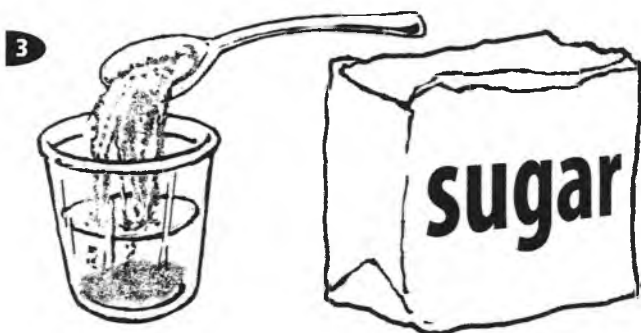
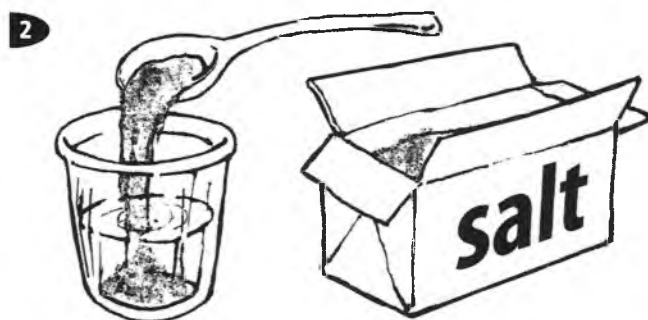
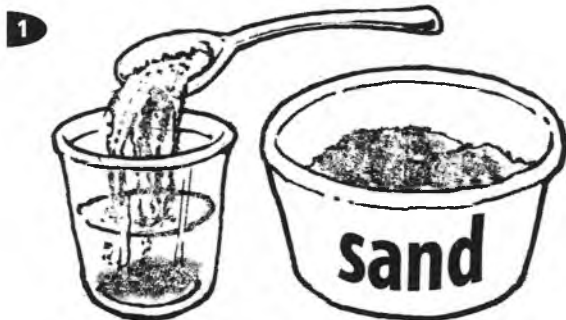

## 3 What will dissolve in water?

Begin at **S** and colour all the things that dissolve in water in blue and things that will not dissolve in red. Write the names in a list.

l	g	l	a	s	s
o	l	t	w	o	i
o	a	<b>S</b>	a	o	r
w	s	d	n	d	o
r	a	g	u	s	n

- 1 \_\_\_\_\_ 2 \_\_\_\_\_
- 3 \_\_\_\_\_ 4 \_\_\_\_\_
- 5 \_\_\_\_\_ 6 \_\_\_\_\_
- 7 \_\_\_\_\_

Lesson  
2b

# A fair test: which substance dissolves more quickly?

**Fact box**

In a solution:

- a **solute** is a substance that dissolves;
- a **solvent** is the liquid it dissolves in.

**Aims**

- To be able to design and carry out a fair test.
- To find out if salt or sugar dissolves more quickly in cold water.

**Language**

- Writing numbered instructions.
- Vocabulary: *conclusion, diagram, draw, equipment, experiment, fair, insoluble, instructions, list, plan, result, salt, soluble, solute, solution, solvent, substance, sugar, table, test, title, water*

**Extra materials**

- 1 copy of the Activity page per pupil, Audio Track 31 and Audio text from Lesson 5.2a, Audio Track 33, IWB
- Information box from the IWB pop-up in Lesson 5.2a, Activity page; labelled equipment per group: plastic beaker; spoon; cold water; labelled materials for testing: salt, sugar

**Warm up**

- 1 Display the Audio text if needed, play Audio Track 31 from Lesson 5.2a and sing along with the class.
- 2 Ask the class what a fair test is (a test where only one thing is changed and tested at a time).
- 3 Put the pupils into pairs (or small groups) to work together to plan a fair test.

**Procedure**

- 1 Display the Information box from Lesson 5.2a and revise the words: *dissolve, solution, soluble* and *insoluble*.
- 2 Explain that, in a solution, the substance that dissolves is called the *solute* and the liquid it dissolves in is called the *solvent*. Ask the pupils if they can remember 2 substances from Lesson 5.2a that are soluble in water (salt, sugar). Ask *In a salt/sugar-and-water solution, which is the solvent? Which is the solute?*
- 3 Explain that the pupils are going to test salt and sugar to find out which substance dissolves more quickly.
- 4 Show the pupils the materials and equipment they may use. Hand out the Activity sheets.
- 5 Play Audio Track 33 or read the sentences and tell the pupils to listen and follow the text in the Planning box.
- 6 Ask for pupils' ideas to answer the questions and write them on the board, e.g. for the first question: *A fair test to find out if salt or sugar dissolves more quickly in cold water.*
- 7 Allow 5 to 10 minutes for the pupils to discuss the questions with their partner/group and make notes in the Planning box before asking them, in turn, to share their answers with the class.
- 8 Pupils now write up the experiment, except for the results and conclusion.

**Follow up**

- 1 Tell the pupils to read each others' sheets to find out if their instructions are easy to understand.
- 2 Give out the materials and equipment for each group to carry out the practical experiment and write up the results and conclusion, or ask pupils to predict what will happen.
- 3 Display the IWB for the pupils to complete the activity.
- 4 Using another copy of the same Activity sheet, design a different fair test, for example to find out if substances dissolve more or less quickly in cold or hot water.

**Useful websites**

- [www.primaryresources.co.uk/science/dissolving.htm](http://www.primaryresources.co.uk/science/dissolving.htm)
- [www.bbc.co.uk/learningzone/clips](http://www.bbc.co.uk/learningzone/clips)  
Type 8455 or 2287 or 2147, then click *SEARCH* and watch the clip
- [www.bbc.co.uk/schools/digger/7\\_9entry/8.shtml](http://www.bbc.co.uk/schools/digger/7_9entry/8.shtml)  
Click *Next*

**Search terms:** soluble + insoluble, fair test, Why the sea is salt + story

**Cross curricular links**

# A fair test

## 1 T33 Use this table to plan a fair test

PLANNING BOX	
What do you want to find out? Write a short title	
What equipment will you need? Make a list.	
Write some instructions. Put them in order and number them.	
Draw a results table. Note the results.	
What have you found out? Write this in the conclusion.	

## 2 Write up the experiment

Title
Equipment
Instructions
Diagram
Results
Conclusion

Lesson  
3a

# Separating mixtures by sieving and filtering

## Fact box

- A *particle* is a very small, separate piece of material, e.g. a dust or sand particle.
- A mixture of solid particles of different sizes can be separated by *sieving*.
- A mixture of water and insoluble particles can be separated by *filtering*.
- A solution (water and a dissolved substance) can be separated by *evaporation* and *condensation* of the water vapour.

## Aim

- To apply knowledge of the characteristics of materials so as to be able to separate them from mixtures.

## Language

- Comparatives: *bigger than, smaller than*
- Vocabulary: *beaker, diagram, filter, funnel, hole, mixture, net, particle, pour, separate, sieve, size, solution, substance, through*

## Extra materials

- 1 copy of the Activity page per pupil, Audio Track 34, IWB
- stones, dry sand, water, 2 boxes (labelled: *sand, stones*), 2 beakers, a sieve, a funnel, filter paper

## Warm up

- 1 Show the class the stones, sand, water, a sieve and some filter paper and play a game of '10 Silly Questions': begin by pointing to a stone and asking, *Is this a sieve?*
- 2 Write *bigger than* and *smaller than* on the board. Point to the holes in the sieve and ask if the holes are bigger or smaller than the stones (smaller). Explain that there are tiny holes in filter paper and ask if these holes are bigger or smaller than the grains of sand (smaller).

## Procedure

- 1 Mix the stones into the sand in a beaker and ask for ideas about how to separate them.
- 2 Pour the mixture through the sieve. Ask why the stones stay in the sieve and the sand goes through the holes.
- 3 Pour some sand into a beaker of water and ask for ideas about how to separate them.
- 4 Pour the sand and water through the filter paper inside the funnel, collecting the water in a beaker. Ask why the sand cannot go through the filter paper.
- 5 Hand out the Activity sheets and explain that there are many kinds of filters and sieves. Play Audio Track 34 or read the word list and ask the pupils to listen and follow the words on the Activity sheet.
- 6 Put the pupils into pairs to take turns to read out the words and identify the pictures.
- 7 Allow 10 to 15 minutes for the pupils to label all the diagrams.
- 8 Display the IWB and complete the activity with the class for the pupils to check their answers.
- 9 Discuss the answers in groups or as a class.

## Follow up

- 1 List more everyday uses for sieving and filtering, e.g. making coffee.
- 2 Use a magnifying glass to look at the holes in filter paper.
- 3 Design a chute with holes for separating football, tennis and golf balls.

## Useful websites

- [www.bbc.co.uk/learningzone/clips](http://www.bbc.co.uk/learningzone/clips)  
Type 2204 or 2295, then click *SEARCH* and watch the clip
- [www.bbc.co.uk/schools/teachers/keystage\\_2/activities/science4.shtml](http://www.bbc.co.uk/schools/teachers/keystage_2/activities/science4.shtml)  
Scroll down and click on *Different changes*
- [www.bbc.co.uk/schools/digger/7\\_9entry/8.shtml](http://www.bbc.co.uk/schools/digger/7_9entry/8.shtml)  
Click *Next*
- [www.chiddingstone.kent.sch.uk/homework/revision/Science/matsamp.html](http://www.chiddingstone.kent.sch.uk/homework/revision/Science/matsamp.html)

**Search terms:** sieving + separating, filtering + separating

## Cross curricular links

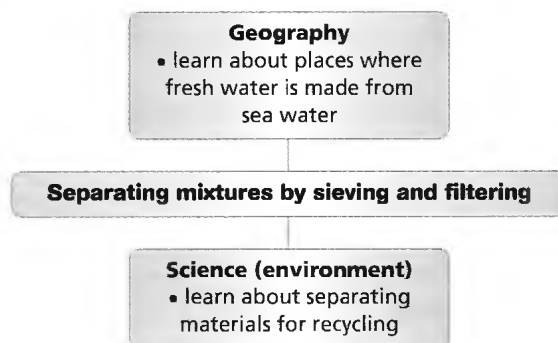

# Separating mixtures by sieving and filtering

T34 Use the words in the box to label the diagrams

- |             |                     |
|-------------|---------------------|
| fishing net | tea leaves          |
| chips       | tennis balls        |
| cooking oil | water               |
| fish        | chip basket         |
| footballs   | filter paper        |
| salad       | net                 |
| sand        | sieve               |
| sea water   | colander            |
| stones      | tea bag             |
| tea         | salt water solution |

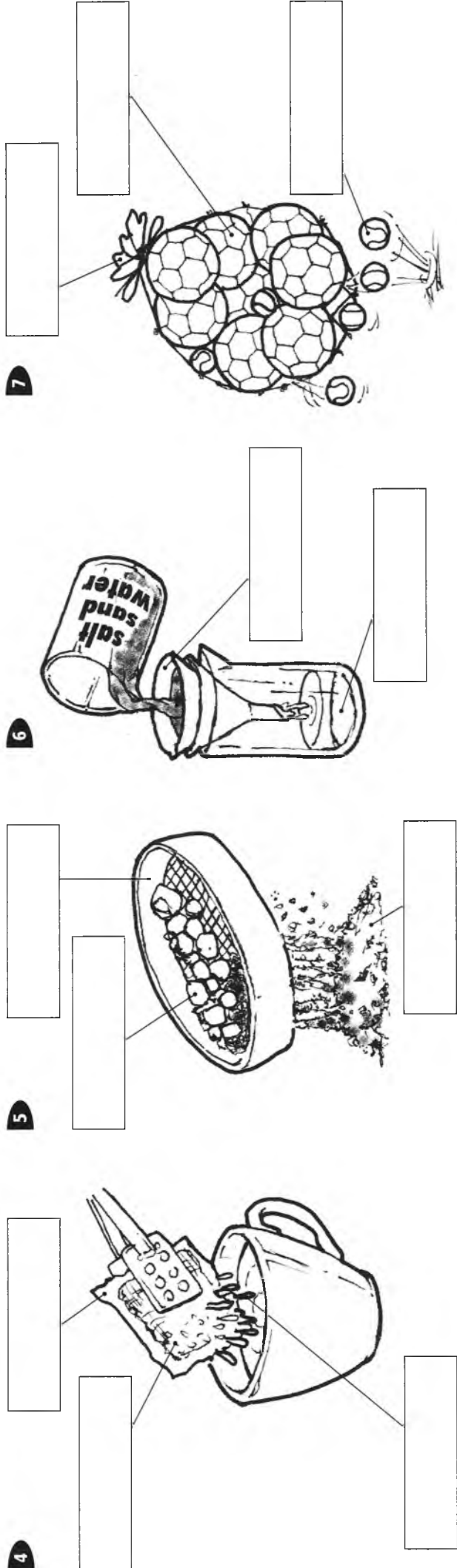
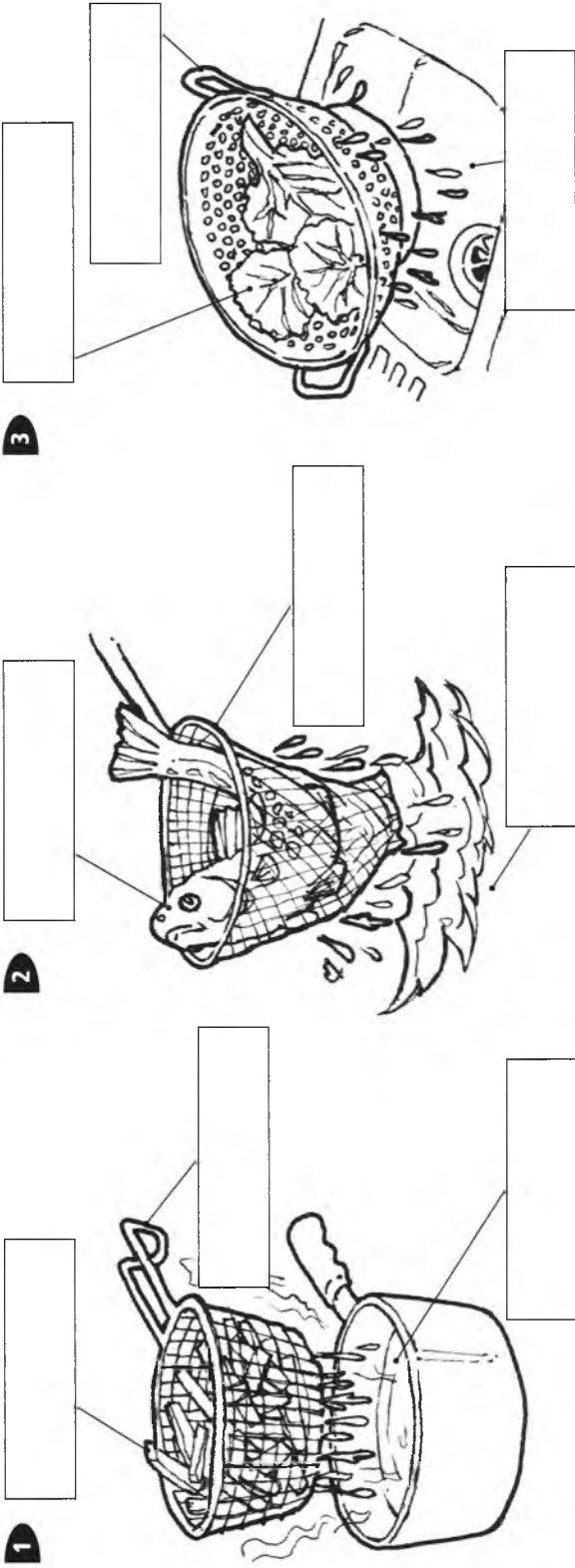

Lesson  
3b

# Reversible and irreversible changes

## Fact box

- Some mixtures can be *reversed* by sieving or filtering, e.g. sand and water.
- Some solutions can be *reversed* by *evaporation* and *condensation*, e.g. salt and water.
- Some mixtures are *irreversible*, e.g. vinegar and bicarbonate of soda.
- Some heated materials change back when cooled, e.g. chocolate.
- Heating causes *irreversible* changes to eggs and bread. Burnt wood changes to ash and smoke.

## Aim

- be able to use knowledge of materials' different properties to identify reversible and irreversible changes.

## Language

- Verb endings: *-ed, -ing*
- Vocabulary: *condensation, evaporate, filter, irreversible, mixture, reversible, separate, sieve, solution*

## Extra materials

- 1 copy of the Activity page per pair/small group, Audio Track 35, IWB
- 1 die per pair/small group, 1 counter per pupil

## Warm up

- 1 Revise material changes. Write *sieve, filter* and *evaporate* on the board.
- 2 Ask the pupils to explain how mixtures and solutions can be changed: *How can a mixture of stones and sand can be separated?* (by sieving) *How can a mixture of sand and water can be changed?* (by filtering) *How can a solution of salt and water be changed?* (by evaporating)

## Procedure

- 1 Write *reversible and irreversible changes* on the board.
- 2 Explain that when mixed materials can be separated by sieving, filtering or evaporating, these are *reversible* changes.
- 3 Ask if it is possible to heat bread to make toast and then to change it back to bread again. Explain that that is an *irreversible* change because a new material has been made and it can't be changed back. Ask for more examples like this, e.g. cooking an egg.
- 4 Hand out the Activity page, counters and dice to the groups/pairs.
- 5 Play the Audio or read the Information box on the Activity sheet. Tell the pupils to listen and follow.
- 6 Explain how to play the game. Players start at box 1. They take turns to throw the die and move forward by the number showing on the die. They must read aloud the words in the box they land on and follow the instructions. Read and discuss some of the instructions with the class.
- 7 Divide the class into two teams and play a couple of rounds to demonstrate.
- 8 Set a time limit for the pupils to play the game in pairs/groups.

## Follow up

- 1 Display the IWB for pupils to complete the word search. Explain that pupils will get a higher score if they highlight each answer correctly first time.
- 2 Using examples from the Activity sheet game make a list of reversible and irreversible changes on the board.
- 3 Find out how reversible changes make it possible to recycle glass and metal.

## Useful websites

- [www.bbc.co.uk/learningzone/clips/Type2286](http://www.bbc.co.uk/learningzone/clips/Type2286), then click *SEARCH* and watch the clip
- [www.bbc.co.uk/schools/teachers/keystage\\_2/activities/science4.shtml](http://www.bbc.co.uk/schools/teachers/keystage_2/activities/science4.shtml)  
Scroll down and click on *Different changes*
- [www.teachingandlearningresources.co.uk/6d-dissolving.shtml](http://www.teachingandlearningresources.co.uk/6d-dissolving.shtml)
- [www.chiddingstone.kent.sch.uk/homework/revision/Science/matsamp.html](http://www.chiddingstone.kent.sch.uk/homework/revision/Science/matsamp.html)

**Search terms:** reversible + irreversible changes

## Cross curricular links

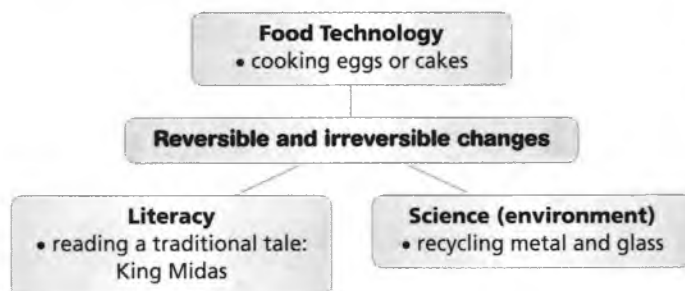

# Reversible and irreversible changes

T35

- Materials can be *changed* by being heated, cooled, burned, mixed or dissolved.
- Mixtures can be sieved or filtered. Solutions can be evaporated and condensed to separate the substances. These are *reversible* changes.
- Sometimes new materials are made that cannot be changed back – these are *irreversible* changes.

## Reverse or miss a turn! A game for 2, 3 or 4 players

You will need a die and counters. Read aloud all the instructions on the game board.

<b>1</b> <b>START</b>	<b>2</b> A china plate is broken! Begin again.	<b>3</b> Melt some chocolate: reversible. Go back 1.	<b>4</b>	<b>5</b>	<b>6</b> Heat an egg: irreversible. Miss a turn!
<b>20</b> Stretch wet clay: reversible? yes: +1/no: -1	<b>21</b>	<b>22</b> Mix sugar and butter: irreversible. Miss a turn!	<b>23</b>	<b>24</b> Heat bread to make toast: irreversible. Miss a turn!	<b>7</b>
<b>19</b>	<b>32</b> Melt glass: reversible. Back 1.	<b>33</b>	<b>34</b> Bend metal: reversible. Back 1.	<b>25</b>	<b>8</b> Mix salt and sand. Say how to reverse this and go again.
<b>18</b> Can you reverse a salt solution? If not, start again!	<b>31</b>	<b>HOME</b>	<b>35</b> Make a cake: irreversible. Miss a turn!	<b>26</b> Can you reverse a sugar solution? yes: +1/no: -1	<b>9</b>
<b>17</b> How do you make a salt solution? Answer or start again!	<b>30</b> Melt cheese: reversible? yes: -1/no: +1	<b>29</b>	<b>28</b> Burn some wood: irreversible. Miss a turn!	<b>27</b>	<b>10</b> Heat clay to make a pot: irreversible. Miss a turn!
<b>16</b>	<b>15</b>	<b>14</b> Cook an apple: irreversible. Go back 3.	<b>13</b>	<b>12</b> Mix sand and stones. Say how to reverse this and go again.	<b>11</b>

Lesson  
1a

## Earth, sun and moon

## Fact box

- The sun, the *Earth* and the moon are *spherical*; they are the same shape as a ball.
- The *sun* is the **biggest** and **hottest**. It is a *star*.
- The *Earth* is a *planet*. It moves around the sun.
- The *moon* is the **smallest**. It is  $\frac{1}{4}$  of the size of *Earth*. It is a *satellite* and moves around the *Earth*.

## Aims

- To understand that the sun, Earth and moon are spherical.
- To understand that Earth orbits the sun and the moon orbits Earth.

## Language

- Comparatives: *big, bigger, biggest, hottest*
- Vocabulary: *Earth, moon, move, orbits, planet, satellite, star, sun*

## Extra materials

- 1 copy of the Activity page per pupil, Audio Tracks 36 & 37, IWB
- 3 different-sized balls, e.g. football, tennis/golf ball, bead/small marble; coloured pencils; pictures of Earth, the sun and the moon

## Warm up

- 1 If you have them available display your pictures of the Earth, the sun and the moon. Ask *What can you see in these pictures?*
- 1 Ask *Which is the biggest and the hottest? (sun) Which is the smallest? (moon) What do they look like?*
- 3 Read the information in the Fact box. Explain that the sun is in the centre and does not move. The Earth moves around the Sun and the moon moves around the Earth.

- 1 Play Audio Track 37/Read the text, pausing after each sentence for the pupils to write the words in the spaces.
- 5 Ask the pupils which word they did not use. Check the answers with the class.
- 6 Display the IWB for pupils to complete the activity.
- 7 If there is time, read the story *Papa Please Get Me the Moon* by Eric Carle.

## Procedure

- 1 Use the 3 balls. Ask a pupil to hold the biggest ball and be the sun in the centre. Ask another pupil to hold the middle-sized ball, be the Earth and move around the Sun. Ask a third pupil to hold the smallest ball, be the moon and move around the Earth.
- 2 Now ask them to stand in a line with the sun first, the Earth next and the moon last to give an idea of their sizes relative to each other.
- 3 Ask *How long does it take for the Earth to move around the sun?* (a year)

## Follow up

- 1 Give out the Activity sheets. Look at activity 1. Ask the pupils to name the 3 shapes and label them.
- 2 Play Audio Track 36/Read the text, pausing after each sentence for the pupils to colour:  
*The sun is the biggest and the hottest star. It is the colour of fire: orange and red with some black spots. The Earth is bigger than the moon. It is a planet. It is blue and green. The blue is the water and the green is the land. The moon is the smallest. It is a satellite. It is white and blue with some black marks.*
- 3 Look at activity 2. Read through the words with the class and explain the activity.

## Useful websites

- [www.bbc.co.uk/schools/scienceclips/ages/9\\_10/earth\\_sun\\_moon.shtml](http://www.bbc.co.uk/schools/scienceclips/ages/9_10/earth_sun_moon.shtml)
- [www.enchantedlearning.com/Home.html](http://www.enchantedlearning.com/Home.html)  
On the left, click *Astronomy*
- [www.chiddingstone.kent.sch.uk/homework/moon/facts.htm](http://www.chiddingstone.kent.sch.uk/homework/moon/facts.htm)

**Search terms:** sun, moon, solar system

## Cross curricular links

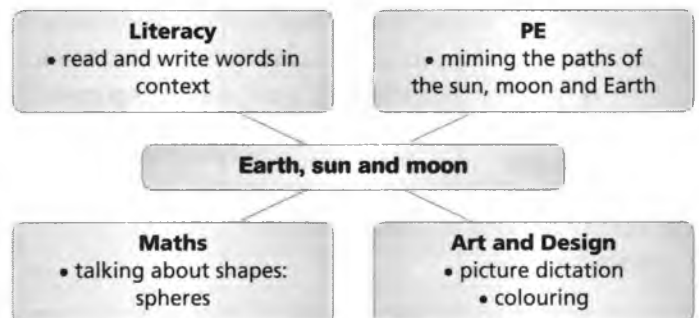

# Earth, sun and moon

**1** T36 Write the names, listen and colour

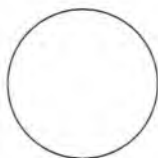
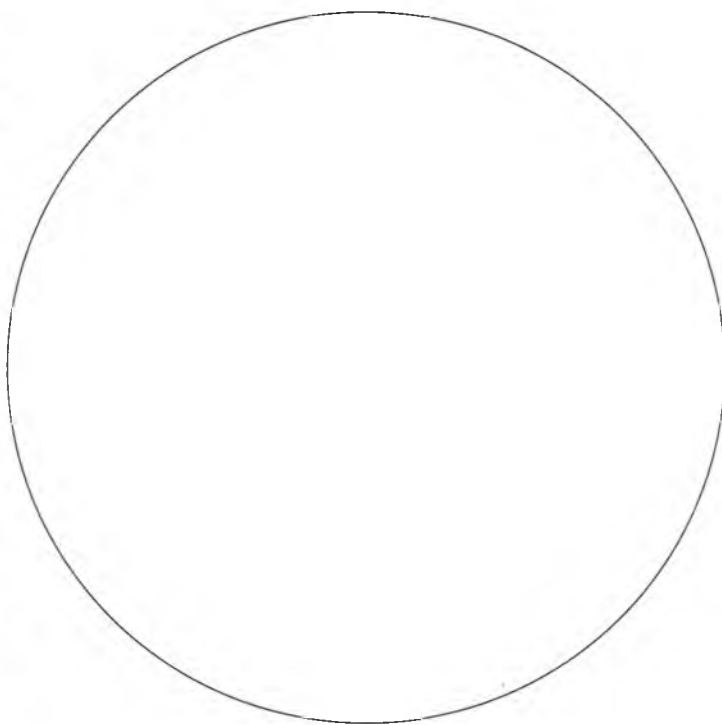

\_\_\_\_\_

\_\_\_\_\_

**2** T37 Listen, match, write the words (you don't need one of them)

Earth	sun	moon	star	planet	satellite	biggest	hottest	year
-------	-----	------	------	--------	-----------	---------	---------	------

The sun is a \_\_\_\_\_ . It

is the \_\_\_\_\_ and the

\_\_\_\_\_ .

The Earth is a \_\_\_\_\_ . It

moves around the \_\_\_\_\_

in one \_\_\_\_\_ .

The moon is a \_\_\_\_\_ . It

moves around the \_\_\_\_\_ .

Lesson  
1b

# Day and night. What time is it?

**Fact box**

- The Earth takes 365¼ days to orbit the sun. This is 1 year.
- The moon takes 28 days to orbit the Earth.
- The Earth turns round and round as it moves around the sun. It makes 1 full turn every 24 hours.
- As the Earth turns away from the sun it gets dark; this is night-time.
- As the Earth turns towards the sun it gets light; this is daytime.

**Aims**

- To understand how day and night are related to the turning of the Earth on its axis.
- To raise awareness of time zones.

**Language**

- Questions: *When do you ...?*
- Time, daily routines, comparison of daily routines
- Vocabulary: *afternoon, away from, daytime, evening, morning, night-time, orbit, towards, turn, weekend*

**Extra materials**

- 1 copy of the Activity page per pupil, IWB
- 3 balls as for Lesson 6.1a, a torch; 1 pencil, 1 ruler and 1 piece of paper with a large circle outline per pupil; a clock/watch with the correct time, coloured pencils, scissors

**Warm up**

- 1 Revise the information about the sun, the Earth and the moon from Lesson 6.1a.
- 2 Discuss how the Earth turns round and round as it moves around the sun.
- 3 Ask a pupil to hold the biggest ball and be the sun. Ask another to hold the middle-sized ball and be the Earth. Give the torch to the sun to shine on the Earth. Ask the Earth to turn round and round and move around the sun at the same time. Ask the class what happens to the light on the Earth. Explain that the side of Earth that is facing the sun is in daytime and the side of the Earth away from the sun is in night-time.
- 4 Put a pencil between the torch and the Earth and show how the light from the torch/sun makes a shadow across the Earth. Discuss how shadows can be used to make a clock to tell the time.
- 5 Use the torch and the pencil to make a shadow clock on the board: draw a circle as a clock face with numbers 1 to 12 around the outside. Ask a pupil to shine the torch on the clock. Hold the pencil in front of the torch so that the shadow falls on any number. Ask *What time is it on this clock?*

**Procedure**

- 1 Explain that before the clocks we use today were invented, people used the sun and shadows to tell the time. Give out the Activity sheets and tell pupils they are going to make a shadow clock like the picture.
- 2 Give each pupil a pencil, ruler and paper with a circle on it. Make your own clock as you demonstrate.
- 3 Tell them to draw 2 lines across the middle of the circle: from side to side and top to bottom. Explain that where the lines cross is the centre of the circle. Tell them to push the pencil through the centre of the circle.

- 4 Use your clock. Take the class to soft ground in a sunny place. Stick your pencil, with the circle attached, in the ground. Look at the time on your watch and show the class how to mark the line of the pencil's shadow on the circle for each hour. They can do this for homework.

**Follow up**

- 1 Display the IWB for pupils to complete the activity.
- 2 Put the pupils into pairs to take turns to ask and answer, as follows: *Choose a school day. What did you do in the morning/afternoon/evening?* Repeat for a weekend day.
- 3 Look at the table on the Activity sheet. Read the names of the days of the week with the class. Ask the pupils to fill in their activities so far today and to complete the table throughout the week for homework.

**Useful websites**

- [www.bbc.co.uk/schools/scienceclips/ages/9\\_10/earth\\_sun\\_moon.shtml](http://www.bbc.co.uk/schools/scienceclips/ages/9_10/earth_sun_moon.shtml)
- [www.enchantedlearning.com/compare/drawandcompare/dayandnight](http://www.enchantedlearning.com/compare/drawandcompare/dayandnight)

**Search terms:** day and night, sun and moon, light and dark

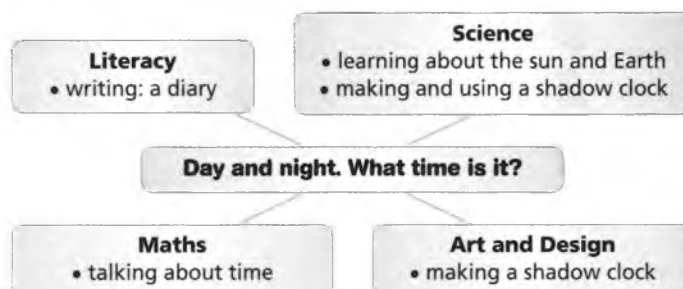
**Cross curricular links**

# Day and night. What time is it?

My week



A shadow clock

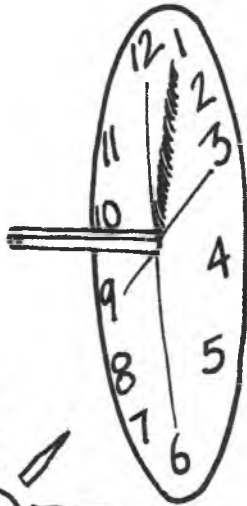

	Monday	Tuesday	Wednesday	Thursday	Friday	Saturday	Sunday
Breakfast							
Morning							
Lunch time							
Afternoon							
Dinner time							
Evening							

Lesson  
2a

## The seasons

## Fact box

- The Earth *tilts* as it moves around the sun.
- The part of the Earth that is tilted towards the sun is *lighter* and *hotter*. The time when this happens is called *spring* and *summer*.
- The part of the Earth that is tilted away from the sun is *darker* and *colder*. The time when this happens is called *autumn* and *winter*.

## Aim

- To understand that the Earth tilts as it orbits the sun, giving us the seasons.

## Language

- Revise months of the year
- Opposites & comparatives: *cold, colder - hot, hotter; dark, darker - light, lighter*
- Vocabulary: *autumn, Earth, equator, moon, north, south, spring, summer, tilt, turn, winter*

## Extra materials

- 1 copy of the Activity page per pupil, Audio Track 38, Audio text, IWB
- felt pens, 2 balloons (1 orange or red, 1 blue or green) per pair of pupils, globe or world map
- [www.enchantedlearning.com/subjects/astronomy/planets/earth/Seasons.shtml](http://www.enchantedlearning.com/subjects/astronomy/planets/earth/Seasons.shtml)  
Scroll down to diagram

## Warm up

- 1 Display the Audio text. Play Audio Track 38 and ask the pupils to listen and follow the words.
- 2 Read the words with the class then play the Audio again and ask the pupils to join in.
- 3 Play the Audio and ask the pupils to clap out the rhythm as they say the words.
- 4 Agree on actions for feeling hot/cold, then ask the pupils to stand and do the actions as they say the chant.

## Procedure

- 1 Put the pupils into pairs and explain that they are going to make a model of the sun and the Earth.
- 2 Give out the balloons and felt pens. Demonstrate how to blow up the orange/red balloon as large as possible for the sun and the blue/green balloon so that it is much smaller than the sun for the Earth.
- 3 Tell the pupils to draw sun spots on the orange/red balloons and the continents on the blue/green ones.
- 4 Read the Fact box to the class. Use the diagram on the website listed above to illustrate how the Earth tilts as it moves around the sun. Ask *What happens at the part of the Earth that is tilted towards the sun?* Explain that at this time that part of Earth is hotter and lighter and this time is called spring and summer. Ask *What do you think happens at the part of the Earth that is tilted away from the sun?* Explain that at this time that part of Earth is colder and darker and this time is called autumn and winter.
- 5 Show the pupils, working in pairs, how to make the Earth tilt and move around the sun at the same time. Demonstrate how the seasons change in one place as the Earth tilts towards and away from the sun.

## Follow up

- 1 Give out the Activity sheet. Look at the pictures. Ask what the pupils can see in each picture. Ask *Why are the pictures different? Why are the trees different? How do the seasons change the trees and plants?*
- 2 Talk about seasonal weather where you are. Ask *What's the weather like in winter/spring/summer/autumn here?* Name the months of each season where you are.
- 3 Look at the globe/world map. Point to the equator and explain that the seasons are different north and south of the equator because of the tilt of the Earth. Discuss if you live north or south of the equator.
- 4 Display the IWB for your hemisphere first. Complete the task with the class, then repeat for the other hemisphere.
- 5 Look at the Activity sheet. Read the months for each season. Pupils tick the correct months for each season where you live, then complete the final sentence.
- 6 For homework, pupils draw the 4 seasons where you live.

## Useful websites (see also Extra materials above)

- [www.eslflashcards.com/preview.php?id=1](http://www.eslflashcards.com/preview.php?id=1)  
Scroll down to PDFs for season/weather flashcards; click to download
- [www.abcteach.com/directory/seasonalseasons](http://www.abcteach.com/directory/seasonalseasons)  
Click on *Fall, Summer, Spring* or *Winter* to find resources

Search term: the seasons

## Cross curricular links

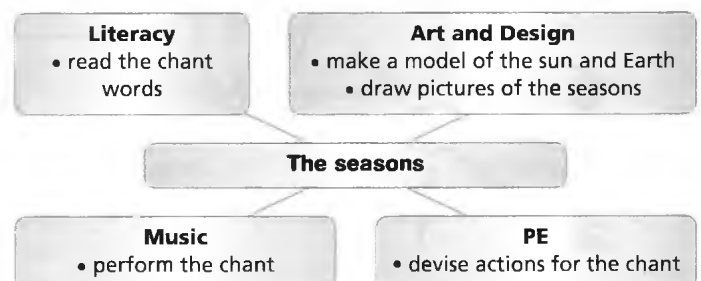

# The seasons

When are the seasons in your country?

Tick the correct boxes and complete the sentence.



**Spring**

March, April, May

September, October, November

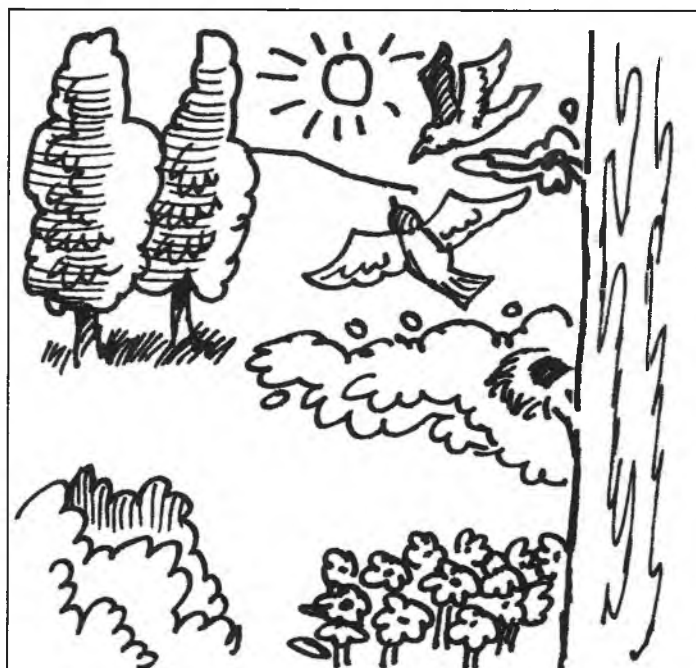

**Summer**

June, July, August

December, January, February



**Autumn**

September, October, November

March, April, May



**Winter**

December, January, February

June, July, August

My country is \_\_\_\_\_ (north/south) of the equator.

Lesson  
2b

## What do we wear in winter?

**Fact box**

- Humans adapt to changes in climate and weather by wearing more clothes when it is cold and fewer when it is hot.
- Humans make their houses warmer in winter and cooler in summer.
- Animals can also adapt to the changes in different ways.

**Aim**

- To understand how humans adapt to changes in climate and the weather.

**Language**

- Revise: weekdays, numbers 1 to 20, most, least
- Vocabulary: boots, coat, cold, cool, dress, gloves, hat, hot, jumper, sandals, scarf, shoes, shorts, socks, swimming costume, T-shirt, trousers, warm

**Extra materials**

- 1 copy of the Activity page per pupil, Audio Track 39, Audio text, IWB

**Warm up**

- 1 Display the Audio text. Listen to Audio Track 39 and read the words with the class.
- 2 Say the words of the song together again and agree a miming action for each verse.
- 3 Play the song again and ask the pupils to mime and sing.
- 4 Display the IWB and complete the activity with the class.

**Procedure**

- 1 Explain that the pupils are going to do a survey of the clothes they are wearing in class today.
- 2 Give out the Activity sheet and look at activity 1. Read the list of clothes across the top of the table.
- 3 Tell the pupils to complete the first row by ticking the items of clothing they are wearing themselves.
- 4 Put the pupils into pairs to take turns to ask and answer each other about each item of clothing, i.e. *Are you wearing (a) ...? Yes/No*. If the answer is *Yes*, they put a tick in the box. If it is *No*, they leave the box blank.
- 5 When they have finished, they count the total number of ticks for each item of clothing and write the numbers (0, 1 or 2 each time) in the *My pair* boxes.
- 6 Put 2 or 3 pairs together to make groups of 4 or 6. Tell them to list the other pair totals (in the *Pair 2* and *Pair 3* boxes), then add all the pair numbers and fill in the *My group* boxes.
- 7 Write the names of the clothes across the board and ask each group for their Group totals. Tell the pupils to write these numbers in the group boxes and then add all the group numbers together and write the *Class total* for each item of clothing on their tables.
- 8 Check the answers by asking for each item: *How many people are wearing (a) ...?*
- 9 Ask *Which clothes are most pupils wearing? Are they clothes for hot weather or for cold weather?*

**Follow up**

- 1 Talk about the weather in your country. Ask *Is it hot or cold?*
- 2 Talk about the kind of clothes you wear in your country. Ask *What do you wear in summer when it's hot/in winter when it's cold?*
- 3 Talk about holidays. Ask *Do you go to hot or cold places? What do you wear on holiday?*
- 4 Tell the pupils to read the list of clothes in activity 2. Ask *Which clothes do we wear in summer/winter?*
- 5 Tell them to draw a line from each item of clothing to the correct picture. Discuss which clothes might be worn in a hot or a cold climate.
- 6 Check the answers with the class.

**Useful websites**

- [www.careinthesun.org/downloads/KS2\\_year\\_567.pdf](http://www.careinthesun.org/downloads/KS2_year_567.pdf)
- [www.bbc.co.uk/schools/whatisweather/weatherandpeople](http://www.bbc.co.uk/schools/whatisweather/weatherandpeople)  
Click on *CLOTHING*

**Search terms:** clothes, adapting to habitat

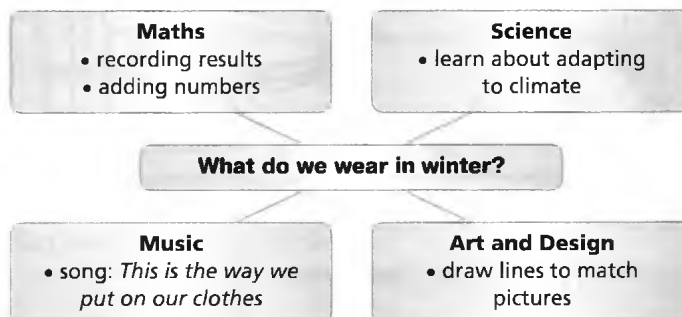
**Cross curricular links**

# What do we wear in winter?















## 1 What are you wearing?

Ask your partner *Are you wearing (a) ...?* Only ✓ the box if the answer is Yes.

	jumper	T-shirt	trousers	dress	shorts	socks	shoes	boots
You								
Partner								
My pair								
Pair 2								
Pair 3								
My group								
Group								
Group								
Group								
Class total								

## 2 Which climate? Where do we wear these clothes?

Draw a line to the correct picture.

coat		boots	
jumper		sun hat	
T-shirt		hat	
trousers		swimming costume	
dress		scarf	
shorts		gloves	
socks		sandals	
shoes			

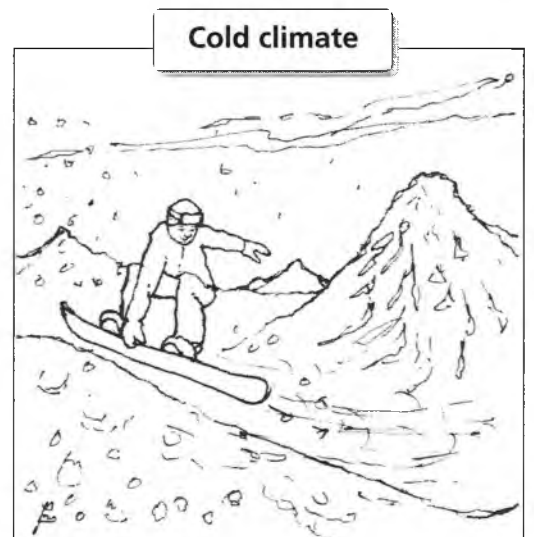
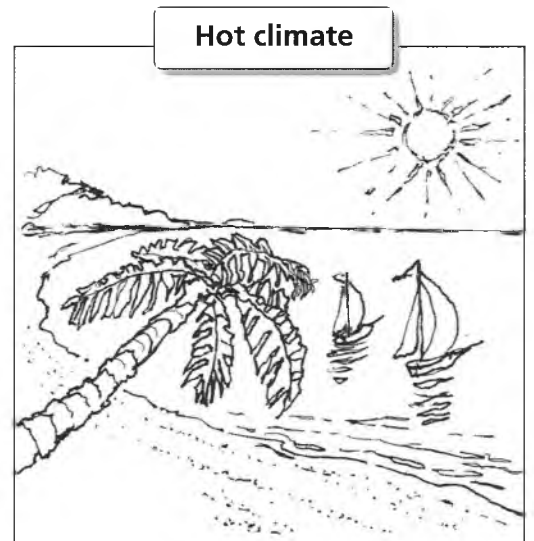

Lesson  
3a

# The solar system

**Fact box**

- The *solar system* consists of the sun in the centre with 8 planets, a few very small (*dwarf*) planets like Pluto, moons, comets, asteroids and meteors all orbiting the sun.
- Comets are made of ice and dust and move very fast around the sun.
- Asteroids are rocks that move around the sun.
- Meteors get very hot and move very fast.

**Aim**

- To identify the planets and main elements of the solar system.

**Language**

- Planets: *Earth, Jupiter, Mars, Mercury, Neptune, Pluto, Saturn, Uranus, Venus*
- Vocabulary: *asteroid, comet, dwarf, inner, meteor, outer*

**Extra materials**

- 1 copy of the Activity page per pupil, IWB
- [www.kidsastronomy.com/solar\\_system.htm](http://www.kidsastronomy.com/solar_system.htm)
- For the Solar System Game: 9 cards, each with a planet name and 1 with *sun*; coloured pencils, scissors, glue sticks

**Warm up**

- 1 Revise the information from Lessons 6.1a and 6.1b.
- 2 Visit the website listed above and look at the diagram of the solar system. Ask *What can you see in the solar system?* Talk about the planets and how they are different in size and colour, etc. Talk about comets, asteroids and meteors. Share the information in the Fact box with the class.
- 3 Display the IWB for the pupils to complete the activity.
- 4 Use the 10 cards you have prepared to play the Solar System Game: invite 10 pupils to the front. Mix up the cards and give one to each pupil. Ask the pupil with the sun to stand in the centre. Ask the other pupils to stand in a line with the planets in the correct order and Mercury closest to the sun. Ask Mercury to walk slowly around the sun, then each planet to walk around the sun outside the planet before them so that the circles get larger. Tell them to repeat their own planet name as they walk. Ask the class why the circles are getting bigger. Explain that the planets move at different speeds in the solar system and are not arranged in a line.

**Procedure**

- 1 Give out the Activity sheets and the coloured pencils. Display the website listed above again as reference.
- 2 Look at activity 1 and tell the pupils to colour the planets.
- 3 Look at activity 2. The pupils refer to activity 1 and draw the planets in order on their orbits round the sun.
- 4 Ask them to complete the name label for each planet. Explain that the first 4 planets are the inner planets and the last five planets are the outer planets.
- 5 Ask the class to say the names of the planets in order, from Mercury to Pluto.

**Follow up**

- 1 Go back to activity 1. Give out the scissors and tell the pupils to cut out the pictures to make 9 cards each.
- 2 Put the pupils in pairs. Each pair spreads the 2 sets of cards face down on the table and mixes them up.
- 3 They take turns to turn over 2 cards and to say the name of each planet. If they find 2 cards the same, they keep them. If they are different, they replace the cards in the same place on the table.
- 4 When all the card pairs have been taken, the pupil with the most pairs is the winner.

**Useful websites** (see also Extra materials above)

- [www.zoomastronomy.com](http://www.zoomastronomy.com)
- [www.abcteach.com/directory/basics/science/solar\\_system](http://www.abcteach.com/directory/basics/science/solar_system)
- [kids.nineplanets.org/intro.htm](http://kids.nineplanets.org/intro.htm)

**Search term:** solar system

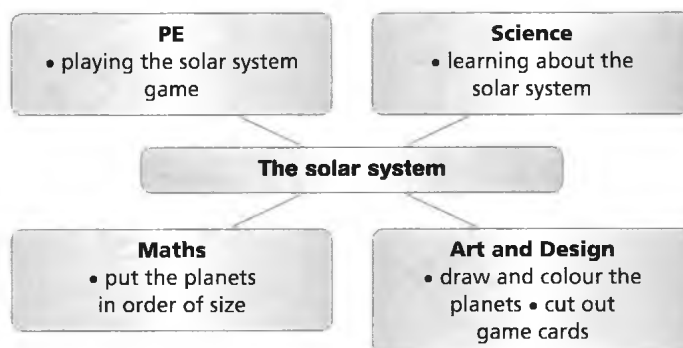
**Cross curricular links**



Lesson  
3b

## The planets

## Fact box

- There are 8 planets in the solar system.
- Mercury is the 1st planet. It is closest to the sun. It is small and hot.
- Venus is 2nd. It is the hottest planet.
- Earth is 3rd. We live on this planet. It has 1 moon.
- Mars is 4th. It is red with 2 small moons.
- Jupiter is 5th. It is the biggest planet. It has many moons.
- Saturn is 6th. It has many lovely rings and many moons.
- Uranus is 7th. It is very big and light blue with many moons.
- Neptune is 8th. It is rocky and has 1 big moon and 2 small moons.

## Aim

- To identify the planets and understand the differences between them.

## Language

- Planets: *Mercury, Venus, Earth, Mars, Jupiter, Saturn, Uranus, Neptune*
- Revise ordinals: *1st to 8th*
- Superlatives: *biggest, closest, coldest, hottest, smallest*

## Extra materials

- per pair: 1 copy of the Activity page, IWB
- [www.kidsastronomy.com/solar\\_system.htm](http://www.kidsastronomy.com/solar_system.htm)
- cards for solar system game from lesson 6.3a; chalk, scissors, counters, coloured pencils

## Warm up

- 1 Revise the planet names. Visit the website above. Ask pupils to describe each planet. (Not Pluto this time.)
- 2 Remind the class of the Solar System game from Lesson 6.3a. Explain that they are going to play a similar game. Find a large space, e.g. a hall or playground. Draw a chalk circle for the sun in the centre and 8 circles as orbits around the sun, 1 for each planet. Write the 1st letter of each planet on its orbit circle.
- 3 Choose 8 pupils to be the planets, one to be the sun and one to be planet X. Ask the planets, one by one, to come and stand on their correct orbit line. Continue until all 8 pupils are in position.
- 4 Now ask all the planets and Planet X to stand away from the Sun. Name any planet, e.g. *Saturn*. The pupil who is Saturn and Planet X must both try to reach the correct orbit circle first. If Planet X wins, that pupil becomes Saturn and the original Saturn becomes Planet X. Continue until all the planets have been called.

## Procedure

- 1 Display the IWB for the pupils to play the matching game.
- 2 Put the pupils in pairs. Give out the Activity sheets, scissors and coloured pencils.
- 3 Tell them to colour the planets, cut out the spinner and put a pencil through the middle to spin it.
- 4 Explain the game. Pupils place their counters at START. They take turns to spin the spinner: they need a 6 to start. On each turn, they spin for a number and count that number of places along the path. They read and carry out the instructions on the square where they land. The first person to reach the sun is the winner.

## Follow up

- 1 Write *My Very Excited Monkey Just Served Us Noodles* on the board. Read the sentence to the class. Ask them to read and repeat. Point to each capital letter and say the planet names. Explain that, using this sentence, the pupils can remember the planet names in order from the sun.
- 2 Ask them to write the 1st letter of each planet on a piece of paper and then to say the planet names again.
- 3 Let them try to make other sentences using words beginning with these letters.
- 4 If there is time, read *The Rooftop Rocket Party* by Roland Chambers.
- 5 For homework, ask the pupils to choose a planet and find out more information about it on the Internet.

## Useful website (see also Extra materials above)

- [www.enchantedlearning.com/Home.html](http://www.enchantedlearning.com/Home.html)  
Click *Astronomy* on the left, then *The Planets*

**Search terms:** the planets, solar system

## Cross curricular links

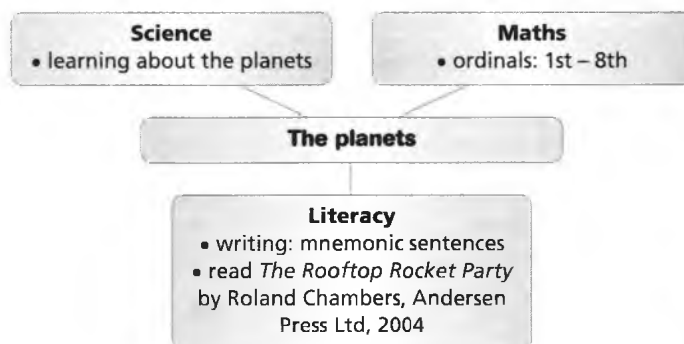

# The planets

## Space race game

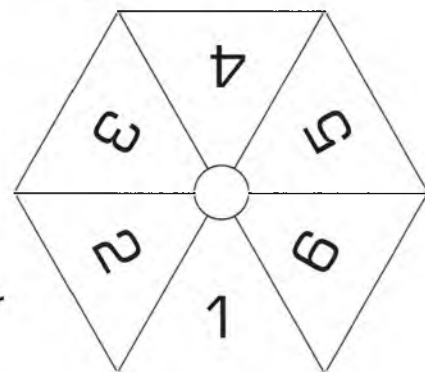
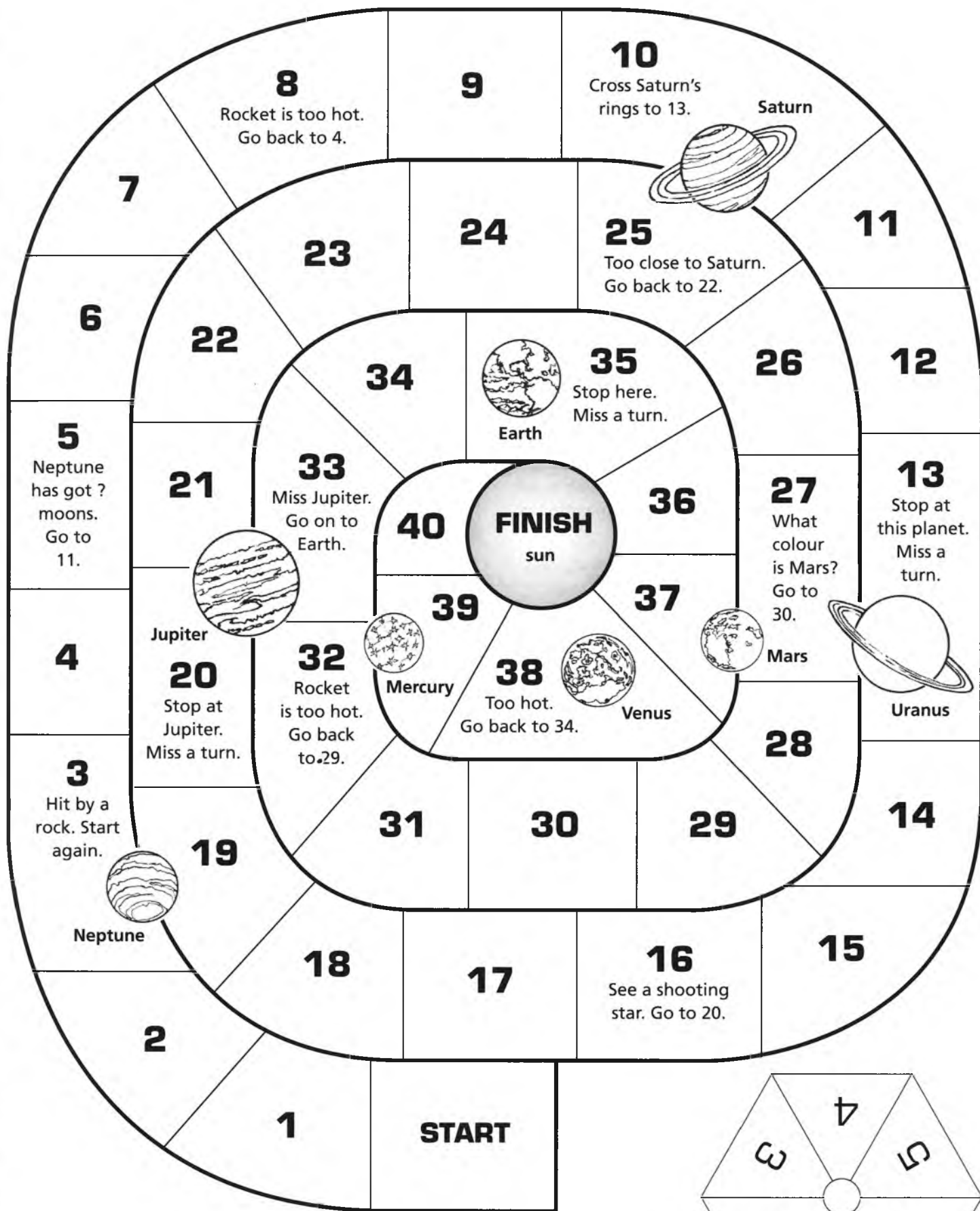

Spinner

Lesson  
1a

## Moving toys: pushes and pulls

## Fact box

- Pushes and pulls are forces.
- Friction, gravity, magnetism and electricity are also forces.

## Aims

- To identify pushes and pulls as forces.
- To understand how toys can be moved by pushing or pulling.

## Language

- Writing labels and captions in the present tense
- Verbs: *brake, force, move, pull, push, slow, stop, start*
- Nouns: *bicycle, car, cart, doll's pushchair, foot, go-kart, heavy, load, road, scooter, skateboard, swing, toy, train*

## Extra materials

- 1 copy of the Activity page per pupil, Audio Track 40, Audio text, IWB
- a toy car

## Warm up

- 1 Give out the Activity sheets. Ask the pupils to name the moving toys. Introduce any new nouns.
- 2 Play '10 Silly Questions'. Point to the train and ask *Is this a go-kart? (No, this is a train.)* Either choose pupils to ask the class more silly questions or allow a few minutes for them to play the game in pairs.
- 3 Display the Audio text. Play and listen to Track 40, then play and sing. Explain any new words and sing again.

## Procedure

- 1 Write *force, pull* and *push* on the board.
- 2 Explain that *force* is needed to move things. *Pushes* and *pulls* are forces. Sometimes you push or pull with your hands; sometimes you push or pull with your feet and sometimes you push or pull with your body.
- 3 Display the toy car and ask how to make it move: *Do you push or pull it? (push)*
- 4 Ask the same question about how to move the other toys on the sheet.
- 5 Put the pupils into pairs and give them a few minutes to ask and answer similar questions.
- 6 Remind the class that some toys can be pushed or pulled.
- 7 Display the IWB for the pupils to complete the activity.
- 8 Tell the pupils to look closely at the pictures on the Activity sheet again. Explain that they must write *push* or *pull* below each one and then convert the dotted line into an arrow to show which way each push or pull goes. Draw some arrows on the board.

## Follow up

- 1 When the pupils have completed the activity, ask about the pulls and pushes to check the answers.
- 2 Remind the class that pushes and pulls are forces.
- 3 Replay the Audio and sing the song again.
- 4 Encourage the pupils to make sentences to match the pictures on the Activity sheet, e.g. *The boy pulls the toy train.* Write them on the board.
- 5 Make a list of things in the classroom that are pushed or pulled when used.
- 6 Make and use *push* and *pull* labels for doors, drawers, etc.

## Useful websites

- [www.bbc.co.uk/learningzone/clips](http://www.bbc.co.uk/learningzone/clips)  
Type 1601, 2435 or 2441 click on *SEARCH* and watch the clip
- [www.bbc.co.uk/schools/scienceclips](http://www.bbc.co.uk/schools/scienceclips)  
Click *Ages 5-6*, then *Pushes and pulls*
- [www.hitchams.suffolk.sch.uk/toy\\_forces/pushing\\_toys.htm](http://www.hitchams.suffolk.sch.uk/toy_forces/pushing_toys.htm)
- [www.firstschoolyears.com/science/resources/games/forces/pushes.htm](http://www.firstschoolyears.com/science/resources/games/forces/pushes.htm)

Search terms: pushes + pulls

## Cross curricular links

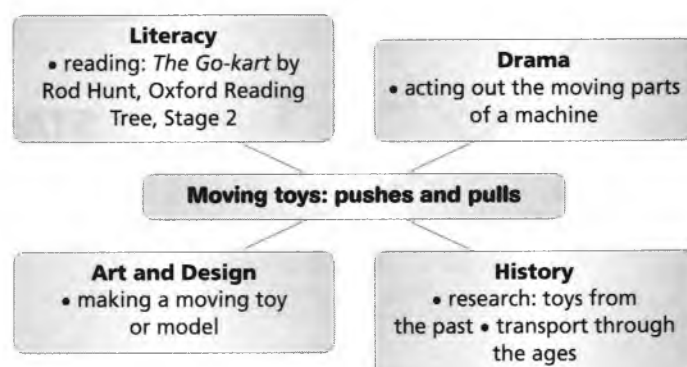

# Moving toys: pushes and pulls

## Push or pull?

Write *push* or *pull* by each picture. Draw an arrow to show the way to pull or push.

1

toy train

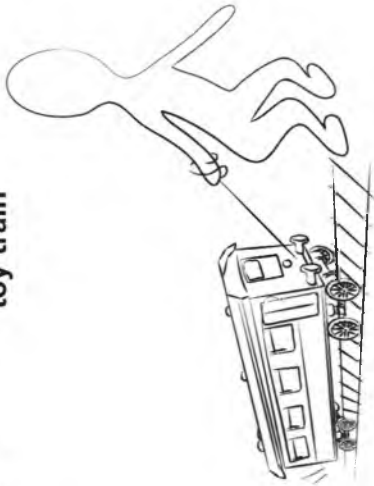

.....

\_\_\_\_\_

2

toy car



.....

\_\_\_\_\_

3

scooter

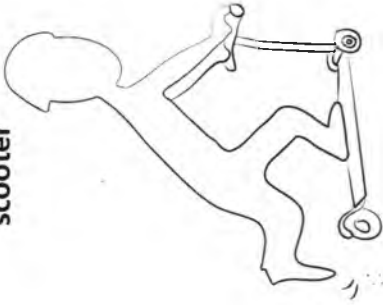

.....

\_\_\_\_\_

4

swing



.....

\_\_\_\_\_

5

go-kart

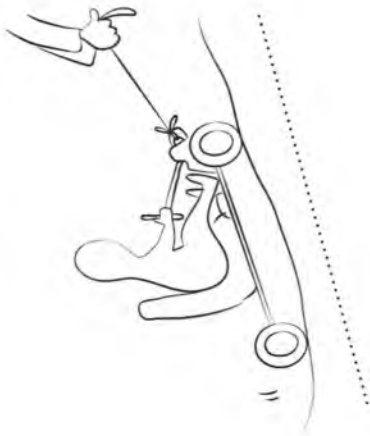

.....

\_\_\_\_\_

6

bicycle

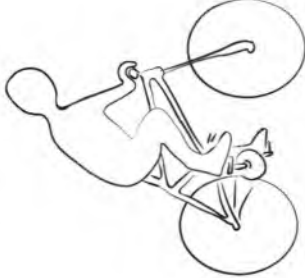

.....

\_\_\_\_\_

7

skateboard

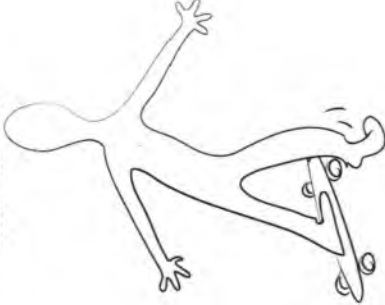

.....

\_\_\_\_\_

8

doll's pushchair



.....

\_\_\_\_\_

Lesson  
1b

## Pushing, pulling and slopes

## Fact box

- Pushes and pulls are forces.
- Slopes (gradients) make pushing and pulling harder or easier.

## Aim

- To understand how slopes affect pushing and pulling.

## Language

- Comparative adverbs: *easy, easier; hard, harder; steep, steeper*
- Vocabulary: *boy, cart, children, donkey, down, flat, foot, girl, go-kart, hill, man, mother, pram, pulling, pushing, road, scooter, slope, swing, up, woman*

## Extra materials

- 1 copy of the Activity page per pupil, Audio Track 40 and Audio text from Lesson 7.1a, Audio Track 41, IWB
- (optional) toy cars

## Warm up

- 1 If needed, display the Audio text from Lesson 7.1a, play Audio Track 40 and sing the song again with the class.
- 2 Display the IWB for the pupils to complete the activity.
- 3 Give out the Activity sheets and talk about the pushing and pulling activities in the pictures.
- 4 Explain that pushes and pulls are forces.

## Procedure

- 1 Play the first sentence on Audio Track 41 or read it and ask the pupils to find the matching words and picture on the Activity sheet. Tell them to write number 1 in the box by picture J.
- 2 Repeat steps 1 and 2 for sentence 2. Check that the pupils have written 2 by picture E.
- 3 Continue to read or play the remaining sentences until the pupils have numbered all the pictures.
- 4 Talk about picture A. Ask *Is there a slope?* (No), then *Is it easy or hard for the boy to pull the go-kart on the flat road?* Write on the board: A. It is easy to pull the go-kart on the flat road.
- 5 Talk about picture J. Ask *Is there a slope?* (Yes), then *Is it easy or hard for the boys to push the go-kart up the slope?* Write on the board: J. It is hard to push the go-kart up the slope.
- 6 Talk about picture D. This slope is steeper. Ask *Is it harder for the donkey to pull the cart up the steep slope?* Write on the board D. This is a steep slope so it is harder for the donkey to pull the cart up.
- 7 Encourage the class to make similar sentences about the other pictures, e.g. E. It is flat. It is easy to pull the door open. I. It is easier to push the cart down the slope.

## Follow up

- 1 Tell the pupils to write 2 correct labels for each picture: (1) *flat, slope* or *steep slope* and (2) *easy, easier, hard* or *harder* by each picture.
- 2 Ask volunteers to read out their answers to the class.
- 3 Practical work: moving toys up/down sloping planks/desktops and recording results for class discussion.
- 4 Possible discussion: *Is it easier or harder to push something down a steep slope?*

## Useful websites

- [www.bbc.co.uk/learningzone/clips](http://www.bbc.co.uk/learningzone/clips)  
Type 1601 or 2454, click SEARCH and watch the clip
- [www.bbc.co.uk/schools/scienceclips](http://www.bbc.co.uk/schools/scienceclips)  
Click Ages 6-7, then Forces and movement
- [www.bbc.co.uk/schools/scienceclips](http://www.bbc.co.uk/schools/scienceclips)  
Click Ages 10-11, then Forces in action or click Ages 8-9, then Friction
- [www.engineeringinteract.org/resources/parkworldplot/parkworldplotlink.htm](http://www.engineeringinteract.org/resources/parkworldplot/parkworldplotlink.htm)  
Click on Click here to launch the game!

**Search terms:** pushes + pulls, slopes + friction, The enormous turnip + story

## Cross curricular links

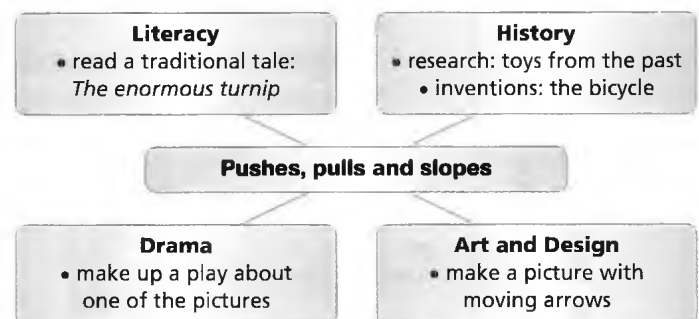

# Pushing, pulling and slopes

## T41 Listen, look and number

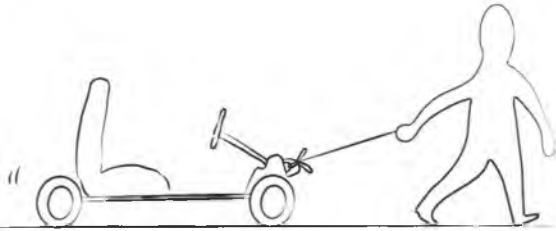

**A**  The boy is pulling the go-kart. \_\_\_\_\_

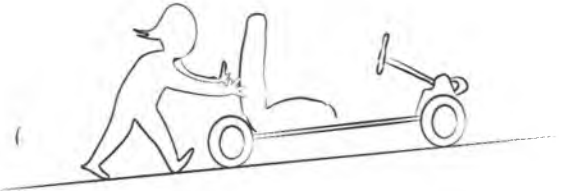

**B**  The girl is pushing the car up the hill. \_\_\_\_\_

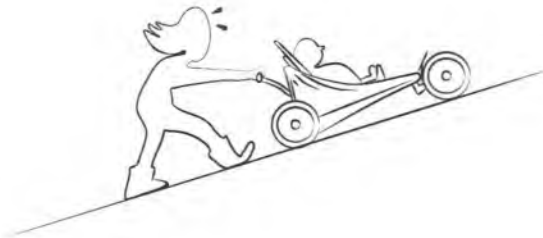

**C**  The mother is pushing the pram up the hill. \_\_\_\_\_

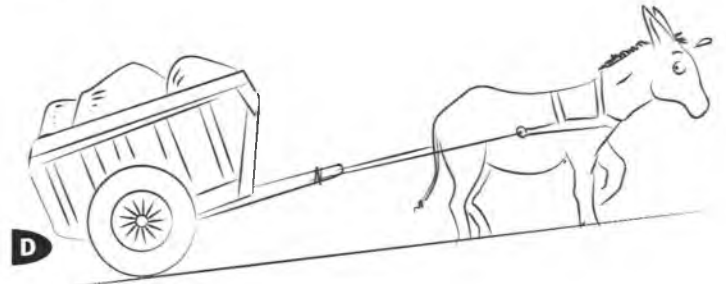

**D**  The donkey is pulling the cart up the hill. \_\_\_\_\_

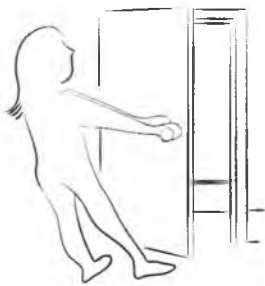

**E**  The woman is pulling the door open. \_\_\_\_\_

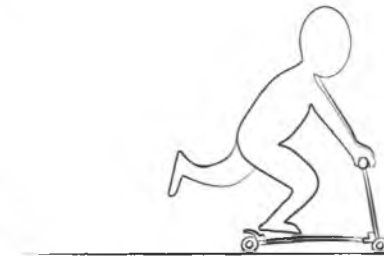

**F**  The boy is pushing the scooter with his foot. \_\_\_\_\_



**G**  The man is pushing the cart up the hill. \_\_\_\_\_

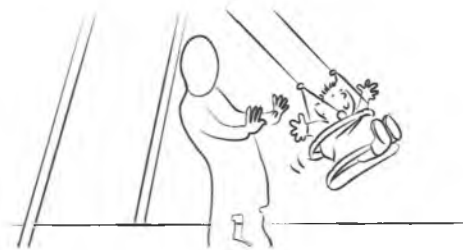

**H**  The girl is pushing the baby on the swing. \_\_\_\_\_

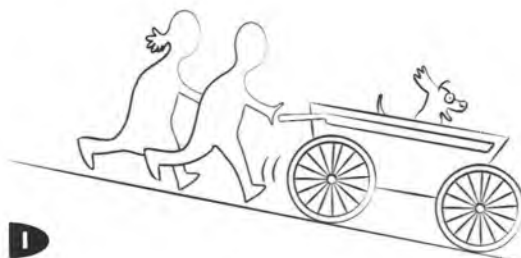

**I**  The children are pushing the cart down the hill. \_\_\_\_\_

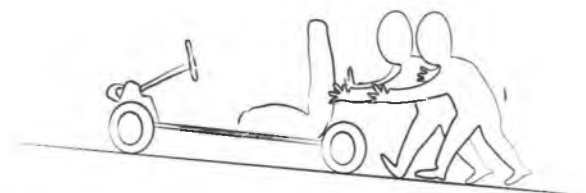

**J**  The boys are pushing the go-kart up the hill. \_\_\_\_\_

Lesson  
2a

## Friction and movement

## Fact box

- Pushes, pulls and friction are forces.
- Gravity, magnetism and electricity are also forces.
- Forces are measured in newtons (N).

## Aim

- To recognise the effect of friction on the movement of objects.

## Language

- Comparative adverbs: *fast, faster, slowly, more slowly*
- Vocabulary: *boots, fast, friction, grip, more, road, rough, rub, slide, slope, smooth, wheels*

## Extra materials

- 1 copy of the Activity page per pupil, Audio Track 40 from Lesson 7.1a, Audio Tracks 42 & 43, Audio texts, IWB
- green coloured pencils, toy car, board and books to make a slope

## Warm up

- 1 Play Audio Track 40 from Lesson 7.1a and sing the song with the class again.
- 2 Remind the class that forces make things start, stop or go faster or more slowly. Write on the board: *Pushes and pulls are forces*. Tell the pupils that there is another kind of force, called *friction*.
- 3 Display Audio text for Track 42 and introduce the song. Play Track 42. Ask the class to listen and then join in.
- 4 Display IWB Task 1 for the pupils to complete the activity.

## Procedure

- 1 Write on the board: *Friction is a force. It slows things down. When one thing rubs on another there is friction*. Read the sentences to the class.
- 2 Give out the Activity sheets. Look at picture 1. Explain that the boy is using his foot as a brake. When he rubs his shoe on the ground, he is using friction to slow the scooter down.
- 3 Ask the pupils to look at pictures 2, 3 and 4. Play Audio Track 43 or read these sentences: *Tom goes down the slide. He goes fast. Anna goes down the slide. She wants to go faster than Tom but she goes more slowly. Anna takes off her big boots. Now she goes as fast as Tom.*
- 4 Ask who goes faster on the slide at first (Tom). Discuss why Anna slides more slowly at first and how taking off her boots makes her go faster.
- 5 Explain that friction slows down both Tom and Anna, but Anna's big boots make more friction as they rub on the slide and that makes her go more slowly.
- 6 Point to pictures 5 and 6 of the men on skis. Explain that the snow is smooth but the grass is rough. Ask the pupils to say which skier is faster and where there is more friction.
- 7 Tell the pupils to write their answers in sentences below the pictures and to colour the grass green. Check the answers with the class.
- 8 Display and complete IWB Task 2 with the class.

## Follow up

- 1 Show the class a toy car, some books and a board. Ask a pupil to make a slope and let the car go down it.
- 2 Discuss what materials can be put on the slope to make more friction, so that the car will go more slowly.
- 3 Ask *When is friction helpful?* List their answers on the board, e.g. *stopping a car, trainers*
- 4 Make up new verses for the song *Friction on the bus*, e.g. *Friction on the bikelskates/car*.
- 5 Ask the class if they know the name of the unit used to measure force (newton).

## Useful websites

- [www.bbc.co.uk/learningzone/clips](http://www.bbc.co.uk/learningzone/clips)  
Type 1601, 2177 or 778, click SEARCH and watch the clip
- [www.bbc.co.uk/schools/scienceclips/ages/8\\_9/friction.shtml](http://www.bbc.co.uk/schools/scienceclips/ages/8_9/friction.shtml)
- [www.bbc.co.uk/schools/digger](http://www.bbc.co.uk/schools/digger)  
Click 7-9 yrs Flick's Adventures, then *Stuck on tracks*
- [www.engineeringinteract.org/resources/parkworldplot/flash/concepts/friction.htm](http://www.engineeringinteract.org/resources/parkworldplot/flash/concepts/friction.htm)

**Search terms:** pushes + pulls, slopes + friction

## Cross curricular links

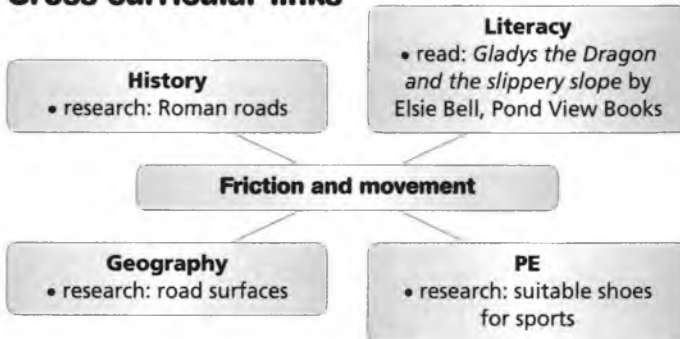

# Friction and movement

## T43 Friction slows things down

### Friction and forces

- Forces make things start and stop or go faster and more slowly.
- Pushes and pulls are forces.
- Friction is a force. It slows things down.
- There is friction when one thing rubs on another.

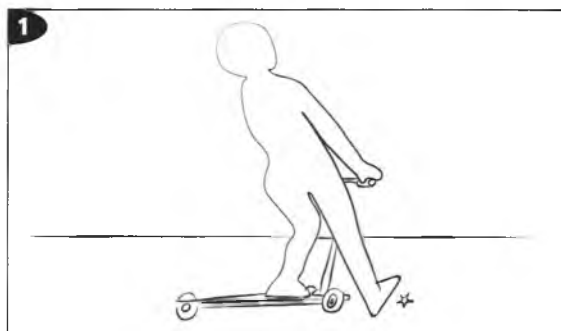

Push, push, push with your foot  
To make the scooter go.  
Brake, brake, brake with your foot  
To make the scooter slow.



Why can the boy slide faster at first?  
What does the girl do so she can slide faster?



Which skier is faster? Where is there more friction?

---

---

# Testing friction

## Fact box

- Pushes, pulls and friction are forces.
- Gravity, magnetism and electricity are also forces.
- Forces are measured in newtons (N).

## Aim

- To investigate the effect of friction on the movement of objects.

## Language

- Writing an instruction text with numbered points
- Materials: *carpet, cloth, elastic bands, foil, leaves, plastic bag, sandpaper*
- Vocabulary: *down, friction, slope, start, stop*

## Extra materials

- 1 copy of the Activity page per pupil, Audio Track 42 & Audio text from Lesson 7.2a, IWB
- per group: planning paper, toy car, second timer, board & books to make a slope; sticky tape/glue stick, labelled materials: carpet, cloth, sandpaper, plastic bag, elastic bands, leaves, foil

## Warm up

- 1 Write on the board: *Forces make things start, stop or go faster or slower.*
- 2 Ask the pupils to name a force. List the answers on the board, e.g. *pulls, pushes, friction.*
- 3 Ask if friction makes things go faster or slower (slower).
- 4 Display the Audio text, play Audio Track 42 from Lesson 7.2a and sing the song with the class again.
- 5 Demonstrate making a slope with books and a board and ask the pupils to suggest what could be put on the slope to make the toy car go down more slowly. Make a list the suggestions on the board.
- 6 Display IWB Task 1 for the pupils to complete the activity.

## Procedure

- 1 Put the pupils into pairs or small groups and explain that they are going to test 3 different materials to see which one makes the toy car go most slowly down the slope. Ask the pupils if they will need to provide more friction or less friction to slow the car (more).
- 2 Revise the concept of a test fair (See Lesson 5.1b), i.e. only one thing is changed, e.g. in this case, the material and not the height of the slope.
- 3 Give out the Activity sheets and the equipment for the tests.
- 4 Ask one pupil to read out the list of materials and another to read out *Instructions: 1 and 2.*
- 5 Tell the pupils to plan their fair test on paper before they write on the Activity sheet.
- 6 Tell the pupils to list the materials their group uses in the box *What you use:* and then complete the list of instructions for the tests in the box *What you do.*
- 7 Pupils then test the 3 materials they have chosen and record the result for each one.

## Follow up

- 1 Display IWB Task 2 and complete the activity with the class. It is possible that some groups will have different results from those given in Task 2. Discuss the reasons for this with the class.
- 2 Ask each group to describe their tests to the class, then compare all the results as a class.
- 3 Discuss whether all the slopes were the same length and height and if that made a difference to the results.
- 4 Test one material on slopes of different heights.
- 5 Discuss with the class if there are any other kinds of forces, apart from pushes, pulls and friction (gravity, magnetism and electricity).

## Useful websites

- [www.bbc.co.uk/learningzone/clips](http://www.bbc.co.uk/learningzone/clips)  
Type 1601, 2177 or 778, click *SEARCH* and watch the clip
- [www.bbc.co.uk/schools/scienceclips/ages/8\\_9/friction.shtml](http://www.bbc.co.uk/schools/scienceclips/ages/8_9/friction.shtml)
- [www.bbc.co.uk/schools/digger](http://www.bbc.co.uk/schools/digger)  
Click *7-9 yrs Flick's Adventures*, then *Stuck on tracks*

**Search terms:** slopes + friction, fair test

## Cross curricular links

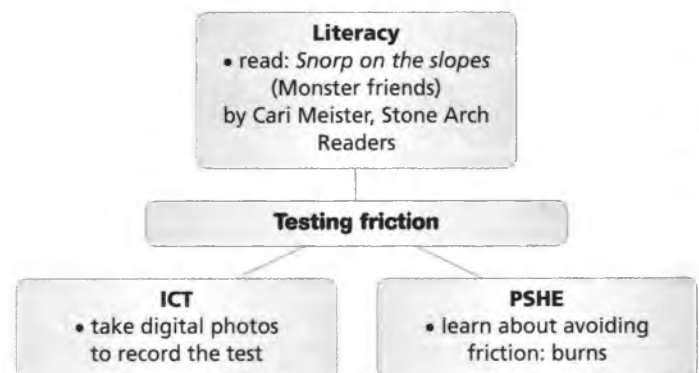

# Testing friction

A fair test to find which material slows a toy car the most

**Materials**



elastic bands

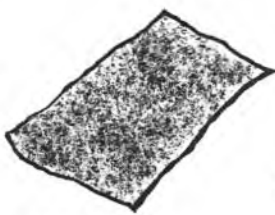

sandpaper



plastic bag



cloth



foil



leaves



carpet



second timer



toy car

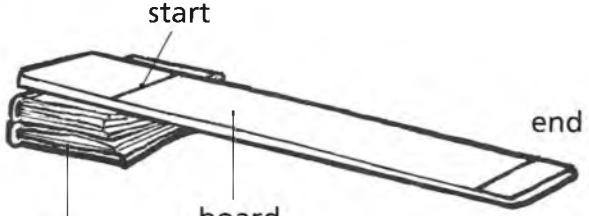

start  
end  
books  
board  
slope

**Materials you use:**

1 \_\_\_\_\_ 2 \_\_\_\_\_ 3 \_\_\_\_\_

**Instructions:**

- 1 Use the board and the books to make the slope. Make a start line near the top.
- 2 Put the car at the start line and time how long it takes the car to go to the end.
- 3 Put (material 1) \_\_\_\_\_ on the slope.

4 \_\_\_\_\_

5 \_\_\_\_\_

6 \_\_\_\_\_

7 \_\_\_\_\_

8 \_\_\_\_\_

Results	
Materials	Time

Which material slows the car the most?  
\_\_\_\_\_

Which material makes the most friction between the slope and the car?  
\_\_\_\_\_

Lesson  
3a

# Magnetic force

**Fact box**

- Magnetism is a force.
- Magnets are surrounded by a magnetic field.
- The opposite ends of a magnet are called poles.
- Opposite poles attract. Like poles repel.

**Aim**

- To understand that when magnets attract and repel, these are forces.

**Language**

- Labels and captions
- Vocabulary: *attract, force, like, magnet, magnetic, magnetism, north, opposite, pole, repel, south*

**Extra materials**

- 1 copy of the Activity page per pupil, IWB
- [www.bbc.co.uk/learningzone/clips/](http://www.bbc.co.uk/learningzone/clips/) Type 2188, then click *SEARCH*
- paper, red and blue pencils, scissors, glue sticks, 2 bar magnets (with north pole marked) per pair of pupils

**Warm up**

- 1 Write on the board: *Forces make things start or stop or go faster or slower.*
- 2 Ask the pupils to name a force. List their answers on the board (*pulls, pushes, friction*).
- 3 Write *magnetism* on the board and explain that magnetism is also a force.
- 4 Visit a website, such as the one listed above, to watch a video clip about magnets.
- 5 Put the pupils into pairs. Give each pair 2 magnets and allow 2 or 3 minutes for experiment and discussion.

- 6 Tell them to make a poster: glue the title at the top, match the pictures and labels and stick them on below. (They can use their magnets to check which pairs of poles attract or repel.)

**Follow up**

- 1 Pupils experiment with their magnets to answer the questions in activity 2. Discuss the answers in class.
- 2 Display the IWB and complete the crossword with the class.
- 3 Make a list of uses for magnets at home and at school.

**Procedure**

- 1 Hold up a bar magnet and explain that the ends of a magnet are called poles. Point to and name the north pole, then the south pole and ask the pupils to do the same with their magnets.
- 2 Give out 1 Activity sheet per pair of pupils. Ask each pair to place 1 magnet on the picture of magnet 1, keeping the south pole on the left. Now, ask them to watch what happens when they put the second magnet on picture 2, again keeping the south pole on the left. Ask different pupils what happened. (If the magnets did not move together, tell pupils to push them 2 or 3 millimetres closer and watch again.) Explain that magnetism pulls the magnets together. Write on the board: *The north pole attracts the south pole.*
- 3 Ask the pupils to put the two north poles together and discuss what happens. Write on the board: *The north pole repels the north pole.* Repeat this experiment with the 2 south poles together and write a 3rd sentence.
- 4 Ask a pupil to read the 3 sentences on the Activity sheet. Ask what the words *like* and *opposite* mean.
- 5 Give out the remaining Activity sheets and the plain paper. Ask the pupils to colour the south poles on all the magnet pictures blue and the north poles red (or match the colours on the class magnets) and then to cut out the title, the coloured magnet pictures and the labels.

**Useful websites** (see also Extra materials above)

- [www.bbc.co.uk/learningzone/clips](http://www.bbc.co.uk/learningzone/clips)  
Type 2349, 2186, 2187 or 2185, click *SEARCH* and watch the clips
- [www.bbc.co.uk/schools/scienceclips/ages/7\\_8/magnets\\_springs.shtml](http://www.bbc.co.uk/schools/scienceclips/ages/7_8/magnets_springs.shtml)
- [www.engineeringinteract.org/resources/parkworldplot/flash/concepts/magneticforces.htm](http://www.engineeringinteract.org/resources/parkworldplot/flash/concepts/magneticforces.htm)

**Search terms:** magnets + springs, magnetic materials

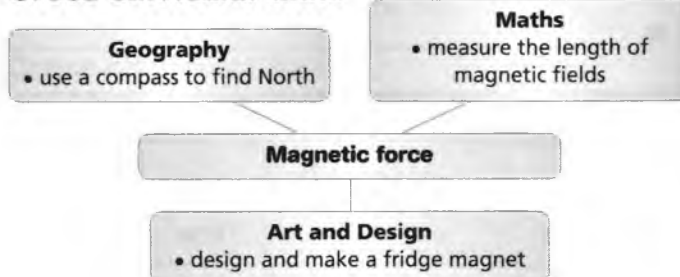
**Cross curricular links**

# Magnetic force

**1** Colour and cut out. Match and stick

## Magnets and magnetism

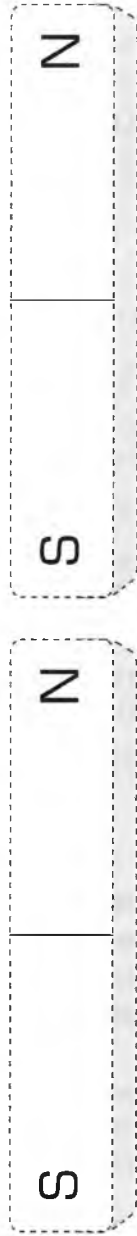

magnet 1

magnet 2

Opposite poles attract

Like poles repel

Like poles repel



**2** Find out, then answer the questions

- 1 What happens when you put 2 north poles together? \_\_\_\_\_
- 2 Can you put 3 magnets together, pole to pole, in a line? Yes/No
- 3 If you can, in which order did you put the magnets? Label the poles with S or N

--	--	--	--

# Working with magnets

## Fact box

- Magnetism is a force.
- Magnets are surrounded by a magnetic field.
- The opposite ends of a magnet are called poles.
- Opposite poles attract. Like poles repel.
- Magnets attract anything made of iron, e.g. steel.
- Magnets also attract alloys of nickel and cobalt.

## Aim

- To investigate magnetic forces.

## Language

- Vocabulary: *alloy, attract, cobalt, field, furthest, iron, magnet, magnetic, magnetism, nickel, paper clips, repel, ruler, steel, strength, stronger, strongest*

## Extra materials

- 1 copy of the Activity page per pupil, Audio Tracks 44 – 46, IWB
- [www.bbc.co.uk/learningzone/clips](http://www.bbc.co.uk/learningzone/clips) Type 2187, click *SEARCH* and watch the clip
- 1 magnet and 1 or 2 paper clips per pupil; English labels on classroom equipment; items for testing, e.g. spoon, jug, scissors; (optional) a simple EFL dictionary

## Warm up

- 1 Visit a website like the one listed above and watch a video clip about magnets. Talk about strong magnets.
- 2 Play Audio Track 44 or read:  
*Magnets can attract or pull things towards them. Some magnets are stronger than others.*  
Pause after each sentence for the pupils to listen and repeat.
- 3 Play Audio Track 45 or read:  
*Magnetism is a force; it pulls or pushes magnetic materials. A magnet attracts anything made of iron and steel. There is a magnetic field round a magnet.*  
Pause after each sentence for the pupils to listen and repeat.

## Procedure

- 1 Give out the magnets and paper clips.
- 2 Ask the class for ideas about how to test the strength of a magnet with paper clips. Discuss the ideas.
- 3 Give out the Activity sheets and ask volunteers to read out the instructions for activity 1.
- 4 Tell the pupils to do the experiment for their own magnet.
- 5 After about 5 minutes, ask a pupil to explain what they have been doing.
- 6 Choose 2 pupils to record all the results on the board and to say whose magnet attracted a paper clip from the furthest distance.

## Follow up

- 1 Play Audio Tack 46 or read the Fact box. Pause after each sentence for the pupils to listen and repeat. Explain *alloy, nickel and cobalt*.
- 2 Display the IWB and complete the tasks with the class.
- 3 Choose a pupil to read out the instructions for activity 2. Allow about 10 minutes for the pupils to carry out the experiment.
- 4 When the pupils have finished activity 2, ask them about their results and if all their predictions were correct.
- 5 Find out how magnets are used to separate metals for recycling.

## Useful websites (see also Extra materials above)

- [www.bbc.co.uk/learningzone/clips](http://www.bbc.co.uk/learningzone/clips)  
Type 2349, 2186 or 2185, click *SEARCH* and watch the clip
- [www.bbc.co.uk/schools/scienceclips/ages/7\\_8/magnets\\_springs.shtml](http://www.bbc.co.uk/schools/scienceclips/ages/7_8/magnets_springs.shtml)
- [www.engineeringinteract.org/resources/parkworldplot/flash/concepts/magneticforces.htm](http://www.engineeringinteract.org/resources/parkworldplot/flash/concepts/magneticforces.htm)

**Search terms:** magnets + activity

## Cross curricular links

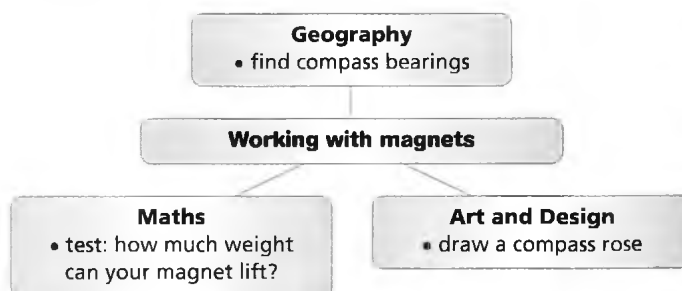

# Working with magnets

## 1 How strong is this magnet?

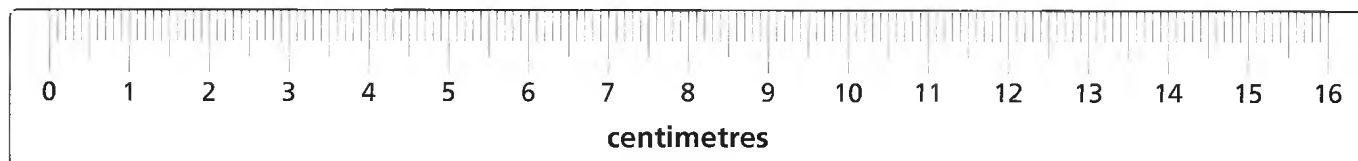

- Place the end of your magnet at the 0 mark on the ruler above.
- Place a paperclip 10 centimetres away – does it move?
- If not, place the paperclip 9 centimetres away – does it move?.
- If it is not attracted to the magnet yet, move it 1 centimetre at a time nearer until it is pulled towards the magnet.
- In the box below, record the distance from which the paperclip is attracted to the magnet, in centimetres.
- Do the same experiment and record the result 3 times.
- Find out whose magnet is the strongest.

	Experiment 1	Experiment 2	Experiment 3
My magnet attracted a paperclip from ... cm			

I found out that the magnetic field of this magnet reaches about \_\_\_\_\_ cm.

## 2 Is it magnetic?

Choose 8 classroom objects and predict which ones are magnetic.  
Test your predictions with a magnet.

Item name	My prediction yes/no	Test result yes/no
1		
2		
3		
4		
5		
6		
7		
8		

Lesson  
1a

## Light sources

## Fact box

- The sun, stars and flames are *natural* sources of light.
- Glow worms, fireflies and some plankton are natural sources of light.
- The moon *reflects* the light of the sun.
- Mirrors and shiny surfaces reflect light.
- Man-made sources only give out light when switched on.

## Aim

- To recognise natural and man-made light sources.

## Language

- Adjectives: *bright, dim, man-made, natural*
- Verbs: *light-lit, reflect, shine, switched on, twinkle*
- Nouns: *bulb, candle, electricity, fire, flame, lamp, light, match, moon, morning, night, source, star, sun, torch*

## Extra materials

- 1 copy of the Activity page per pupil, Audio Tracks 47 & 48, Audio texts, IWB
- candle, matches, torch, mirror

## Warm up

- 1 Ask the pupils where they think light comes from and list their answers on the board.
- 2 Give out the Activity sheets. Tell the pupils to look at the pictures. Point to and name the different light sources with the pupils.
- 3 Play Audio Track 47. Ask the pupils to point to each picture as they hear its name (3 names have 2 pictures each – *candle, match, lamp*).
- 4 Put the pupils into pairs and ask them to take turns to point to and name the pictures.
- 5 Display the Audio text and play Audio Track 48. Ask the pupils to listen, follow the words and then join in.

## Procedure

- 1 Point to the real unlit candle and ask if it is giving out light (No). Explain that it cannot give out light because it has not been *lit*. Light the candle and repeat the question (Yes).
- 2 Ask if the torch is giving out light (No). Explain that it has not been *switched on*. Switch on the torch and repeat the question (Yes).
- 3 Ask if the moon can give out light (No). Explain that it cannot give out light because it is like a mirror and does not have light of its own. It *reflects* the sun's light.
- 4 Allow 5 to 10 minutes for the pupils to write *yes* or *no* to complete the activity on the Activity sheet.
- 5 Ask individual pupils to name things which give out light. Remind the class that the sun, stars and flames are *natural* light sources, but electric lights are *man made*.
- 6 Display the crossword activity on the IWB for the pupils to complete.

## Follow up

- 1 Display the Audio text, replay Audio Track 48 and sing the song again with the class.
- 2 Tell the pupils to cut out the pictures from the Activity sheet and sort them into 3 sets: natural light sources, man-made light sources and light reflectors.
- 3 Demonstrate how to use each picture to illustrate a simple written sentence, such as *The sun gives out light. The moon reflects sunlight*, etc. and ask the pupils to do this for each picture.

## Useful websites

- [www.bbc.co.uk/learningzone/clips](http://www.bbc.co.uk/learningzone/clips)  
Type 1623 or 2428, click *SEARCH* and watch the clip
- [www.bbc.co.uk/schools/scienceclips/ages/5\\_6/light\\_dark.shtml](http://www.bbc.co.uk/schools/scienceclips/ages/5_6/light_dark.shtml)
- [www.engineeringinteract.org/resources/alienattack/flash/concepts/sourcesandrays.htm](http://www.engineeringinteract.org/resources/alienattack/flash/concepts/sourcesandrays.htm)

**Search terms:** light sources, light and dark, Twinkle, twinkle little star + song

## Cross curricular links

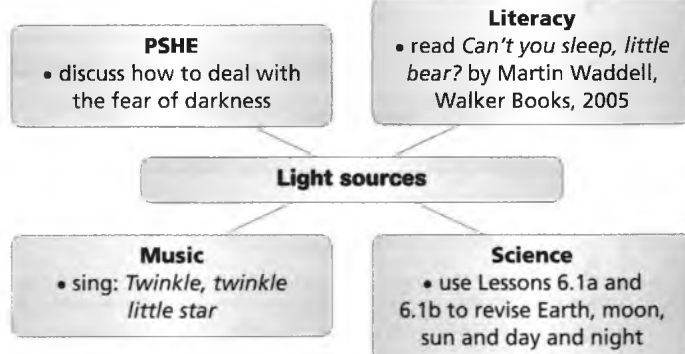

# Light sources

## T47 Which things are giving out light?

Write *yes* or *no* by each picture.

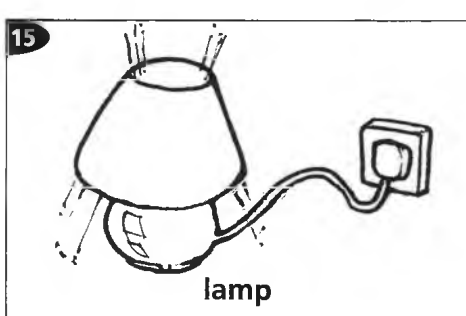
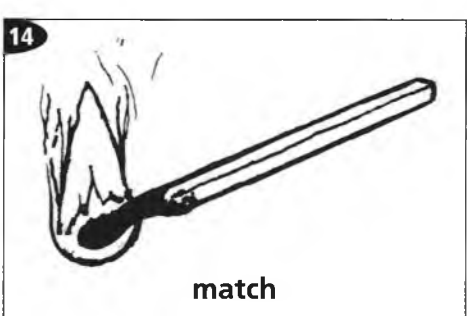
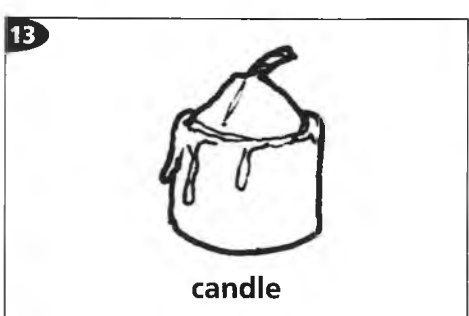
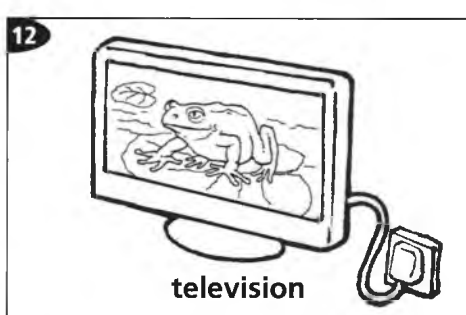
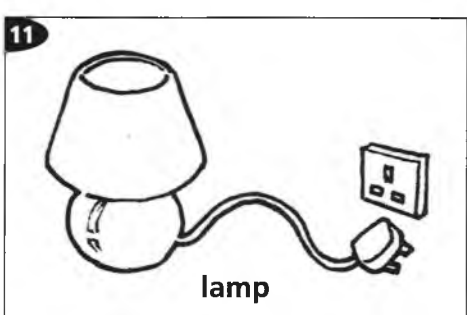
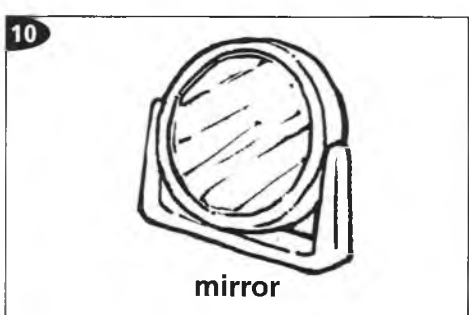
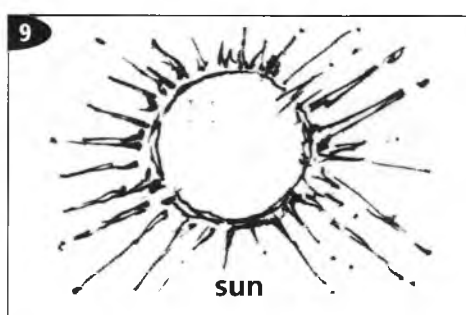
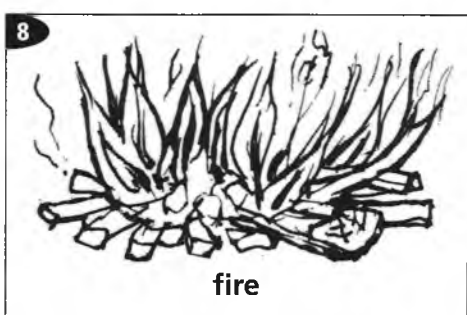
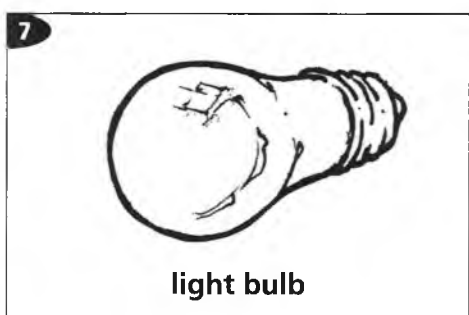
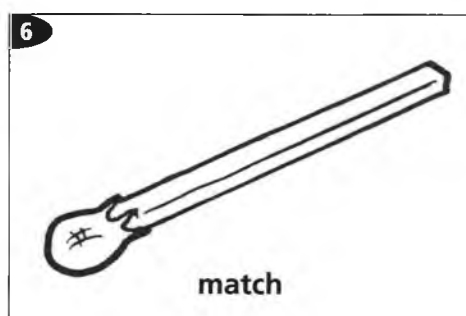
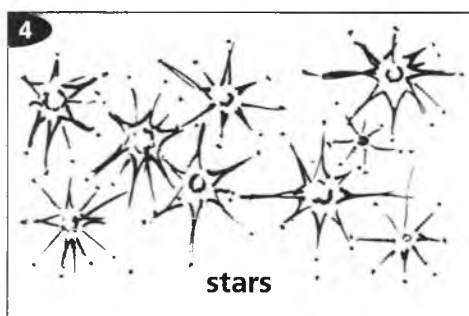
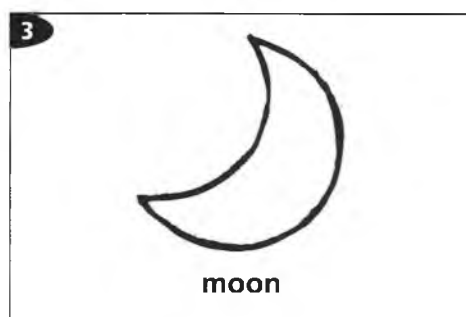
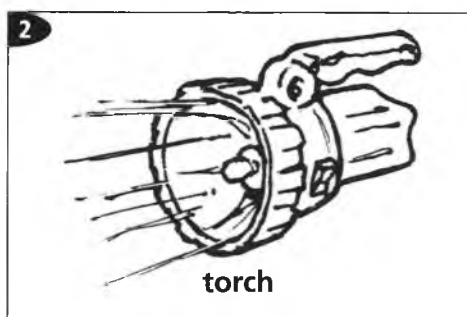
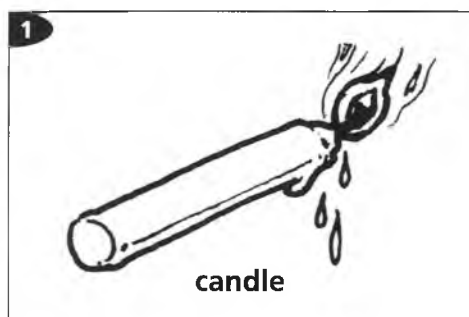

# Light and shadows

## Fact box

- Light travels at 299, 792, 458 metres per second.
- Light travels in straight lines.
- Shadows are formed when light is blocked.

## Aim

- To understand that shadows appear when light is blocked.

## Language

- prepositions: *behind, in front*
- Vocabulary: *blocks, car, cat, chair, duck, elephant, flower, hand, house, light, match, mug, shadow, table, tree*

## Extra materials

- 1 copy of the Activity page per pupil (A3 if possible), Audio Track 49, Audio text, IWB
- an electric lamp/torch, toys to make shadows, scissors, glue sticks, exercise books/plain paper
- [www.bbc.co.uk/schools/scienceclips/ages/7\\_8/light\\_shadows.shtml](http://www.bbc.co.uk/schools/scienceclips/ages/7_8/light_shadows.shtml)

## Warm up

- 1 If possible, visit the website listed above to play a shadow game.
- 2 Display the Audio text. Play Audio Track 49 or read the words and ask the class to listen and follow. Play the Audio again and ask the pupils to join in.
- 3 Display the IWB and complete the activity with the class.
- 4 Switch on the light and hold a toy so that the light casts a shadow behind the toy. Explain that the toy stops, or *blocks* the light. Ask if the shadow is *behind* or *in front of* the toy.
- 5 Turn the lamp to make a shadow in front of the toy and ask where the shadow falls.
- 6 Choose different pupils to make shadows with the toys.

## Procedure

- 1 Give out the scissors. Put the pupils into pairs and give out one Activity sheet per pair.
- 2 Look at the pictures and practise the nouns with the class.
- 3 Tell each pair to cut out the joined pairs of pictures, take five each and use them to play dominoes. Pupil 1 says *Here is a cat* and Pupil 2 says *Here is the cat's shadow*.
- 4 Give out the remaining Activity sheets and ask the pupils to cut out all the individual pictures to use to play 'Snap', naming each picture in turn.
- 5 Give out the plain paper and tell the pupils to write *Shadows* at the top. Ask them to match, paste and label the pairs of pictures below the title.

## Follow up

- 1 Display the Audio text and play Audio Track 49 again.
- 2 With the class, devise some actions to accompany the chant, and practise performing it.
- 3 Experiment with shadows: ask the pupils to find out how to make them bigger or smaller.
- 4 Watch and record how particular shadows move during the day.

## Useful websites (see also Extra materials above)

- [www.bbc.co.uk/learningzone/clips](http://www.bbc.co.uk/learningzone/clips)  
Type 2171 or 2175, click *SEARCH* and watch the clip
- [www.bbc.co.uk/schools/scienceclips/ages/7\\_8/light\\_shadows.shtml](http://www.bbc.co.uk/schools/scienceclips/ages/7_8/light_shadows.shtml)
- [www.engineeringinteract.org/resources/alienattack/flash/concepts/shadows.htm](http://www.engineeringinteract.org/resources/alienattack/flash/concepts/shadows.htm)

**Search terms:** light sources, light and dark

## Cross curricular links



# Light and shadows

## Shadow games

Cut out pairs of cards to use as dominoes. Cut out single cards to play 'Snap'.



car



shadow of a duck



cat



shadow of an elephant



shadow of a flower



chair



duck



shadow of a cat

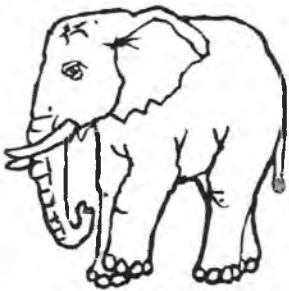

elephant



shadow of a house



flower



shadow of a car



house



shadow of a mug



mug



shadow of a tree

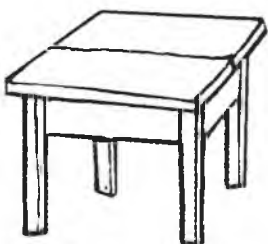

table



shadow of a chair



tree



shadow of a table

# Reflections

## Fact box

- Flat mirrors reverse the image.
- Convex mirrors give a wide image. They are used in cars.
- Concave mirrors turn the image upside down. They are used in telescopes.
- Bicycle reflectors reflect light not images.

## Aim

- To investigate reflections in mirrors and shiny surfaces.

## Language

- Prediction – future tense: *I will see*
- Recording – past tense: *I saw*
- Vocabulary: *concave, convex, face, flat, image, light, mirror, nothing, reflection, reverse, upside down*

## Extra materials

- 1 copy of the Activity page per pupil, Audio Track 50, Audio text, IWB
- [www.bbc.co.uk/learningzone/clips](http://www.bbc.co.uk/learningzone/clips) Type 3005, click *SEARCH* and watch the clip
- per group: 2 flat mirrors, a pencil, a large spoon, a bicycle reflector

## Warm up

- 1 Display the Audio text and play Audio Track 50 twice. Ask the pupils to listen first and then join in.
- 2 Ask 2 confident pupils to role play the Person and the Image at the front while you replay the Audio.
- 3 Put the remaining pupils into pairs to role play the parts while they say the chant.
- 4 Hand out a few mirrors and shiny objects and ask about the *reflections* in them.
- 3 Display and complete the activity on the IWB.
- 4 Talk about road safety and, if possible, watch the clip on the website listed above.
- 5 Find more shiny objects and look at the images they reflect.
- 2 List where mirrors and reflectors are found and how they are used.

## Procedure

- 1 Hand out the Activity sheets and read through the list of useful words at the bottom with the class.
- 2 Point to the first picture in Activity 1 and ask the pupils to predict what they will see in this mirror.
- 3 Repeat the question for each picture and introduce the new words as needed.
- 4 Put the pupils into pairs to discuss each picture in the same way and then write their predictions.
- 5 When they have completed activity 1, ask several pupils to share their answers with the class.
- 6 Put the pupils into small groups, give out the mirrors, etc. to set up exactly as in the pictures.
- 7 Ask all the pupils to look in the mirror/reflector for each picture and write and draw what they can see.
- 8 Choose some pupils to read their sentences aloud.

## Follow up

- 1 Discuss the pupils' findings with the class. Ask if all the mirrors reflect in the same way and how the curved mirrors (or sides of the spoon) change the images.
- 2 Ask what can be seen in the reflector. Explain that it reflects back the light, not an image. Discuss how this can be useful when it is dark.

## Useful websites (see also Extra materials above)

- [www.bbc.co.uk/learningzone/clips](http://www.bbc.co.uk/learningzone/clips)  
Type 1625, click *SEARCH* and watch the clip
- [www.bbc.co.uk/schools/scienceclips/ages/5\\_6/light\\_dark.shtml](http://www.bbc.co.uk/schools/scienceclips/ages/5_6/light_dark.shtml)
- [www.sparklebox.co.uk/topic/world-around-us/light-and-dark/#.T576SLP2Ysd](http://www.sparklebox.co.uk/topic/world-around-us/light-and-dark/#.T576SLP2Ysd)
- [www.engineeringinteract.org/resources/alienattack/flash/concepts/reflectionmirrors.htm](http://www.engineeringinteract.org/resources/alienattack/flash/concepts/reflectionmirrors.htm)

**Search terms:** reflection, refraction, mirrors

## Cross curricular links

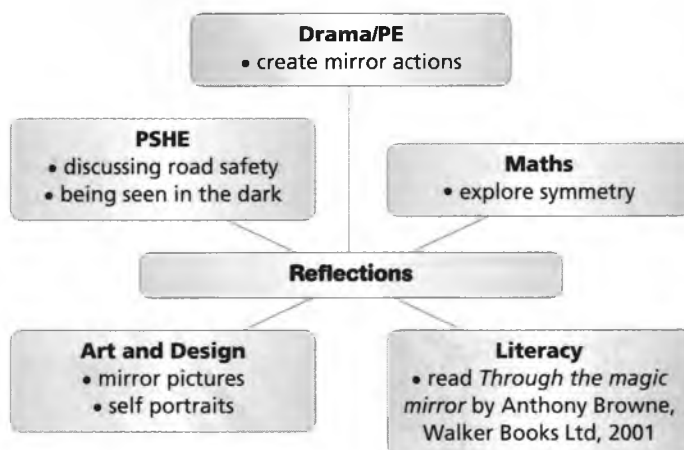

# Reflections

## 1 What will I see in the mirror?

## 2 What I saw in the mirror

1

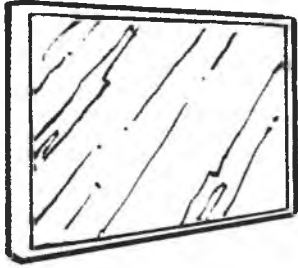

flat mirror

I predict \_\_\_\_\_

1

I saw \_\_\_\_\_

2

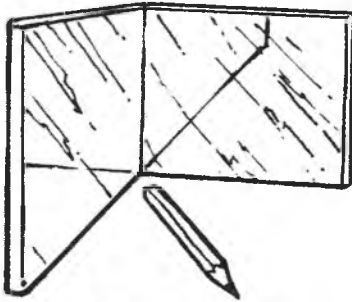

2 flat mirrors  
at 90°

I predict I will see \_\_\_\_\_ pencil

2

I saw \_\_\_\_\_

3

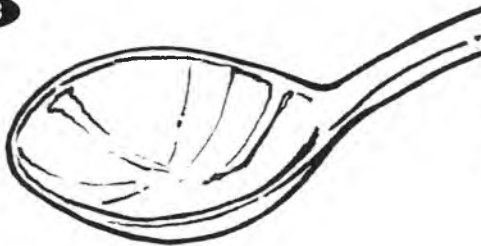

concave  
mirror

I predict \_\_\_\_\_

3

I saw \_\_\_\_\_

4

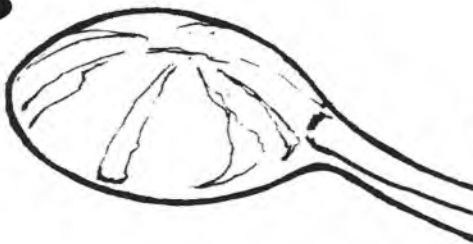

convex  
mirror

I predict \_\_\_\_\_

4

I saw \_\_\_\_\_

5

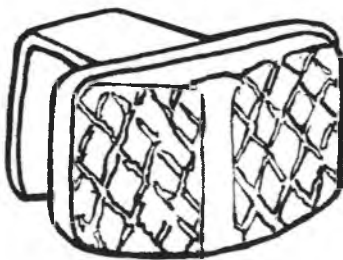

reflector

I predict \_\_\_\_\_

5

I saw \_\_\_\_\_

Useful words: *face, image, reversed, bigger, smaller, upside down, nothing, reflection*

Lesson  
2b

## Everyday sounds and volume

## Fact box

- The sound words on the worksheet are both nouns and verbs.
- Sounds are *vibrations*.
- Sound vibrations travel through *air* at 343 metres per second
- *Volume* (loudness) is measured in *decibels*.
- *Pitch* = how high or low a sound is.

## Aims

- To understand that sound is produced when objects vibrate.
- To identify and name everyday sounds.

## Language

- Comparisons: *louder, quieter*
- Onomatopoeia
- Vocabulary: *air, bang, crackle, ear, footstep, hear, hiss, listen, pop, rattle, shout, snap, sound, squeak, vibrate, vibration, volume, whisper, whistle*

## Extra materials

- 1 copy of the Activity page per pupil, Audio Tracks 51 – 53, IWB
- radio/CD player with volume control, coloured pencils, scissors, glue sticks, paper

## Warm up

- 1 Tell the pupils to listen very carefully then turn on the radio/CD very quietly. Ask a pupil to turn up the volume slowly until it is very loud then say *That is too loud* and turn off the radio.
- 2 Ask what the pupil did to make the *sound* so loud. Explain that they turned *up* the volume.
- 3 Write *volume = loud or soft* on the board.
- 4 Play Audio Track 51 (or make some loud and soft sounds) and ask how these sounds are made.

## Procedure

- 1 Give out the Activity sheets. Play Audio Track 52, or read the chant in activity 1 on the Activity sheet, and ask the pupils to listen and follow the words. Ask/Explain the meaning of the nouns: *vibration, volume* and *pitch*.
- 2 Explain that different sounds have different names. Display and complete the activity on the IWB.
- 3 Play Audio Track 51 again and ask the pupils to look for the matching sound words and pictures in activity 2 on the Activity sheet.
- 4 Play Audio Track 53 and ask the class to listen very carefully. Explain the activity.
- 5 Play Audio Track 53 again, pausing after each line for the pupils to repeat it then to match and join the words and pictures. Give out coloured pencils so pupils can draw different coloured lines for clarity.
- 6 Give out the scissors, glue and paper and allow time for the pupils to cut out the words and pictures from activity 2. Tell them to use the words and pictures to make posters about the sounds.

## Follow up

- 1 Replay Audio Track 51 and ask volunteers to name the sounds.
- 2 Chant the *Noisy Day Rap* as a class.
- 3 Use a dictionary to find more sound words such as *roar* or *quack*.

## Useful websites

- [www.bbc.co.uk/schools/scienceclips/ages/9\\_10/changing\\_sounds.shtml](http://www.bbc.co.uk/schools/scienceclips/ages/9_10/changing_sounds.shtml)
- [www.bbc.co.uk/learningzone/clips](http://www.bbc.co.uk/learningzone/clips)  
Type 2420, 2418 or 1603 then click *SEARCH*, listen and watch the clip
- [www.engineeringinteract.org/resources/oceanodyssey/oceanodysseylink.htm](http://www.engineeringinteract.org/resources/oceanodyssey/oceanodysseylink.htm)  
Click the link next to the light bulb logo

**Search terms:** sounds activity, physical processes + sound

## Cross curricular links

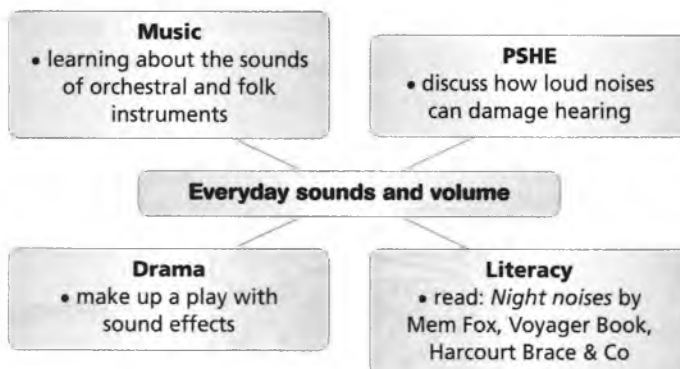

# Everyday sounds and volume

## 1 T52 What is sound?

- What is sound?  
 It's shaking air.  
 It's vibrating everywhere.  
 It's not just the air that shakes.  
 Sound can go through hills and lakes.  
 What is volume?  
 Loud or soft?  
 You'll have to shout, I'm in the loft!  
 What is pitch?  
 It's high or low, vibrations fast, vibrations slow.

Sound vibrations I can hear, all end up inside my ear!

## 2 T53 Noisy day rap

Draw lines to join the words and pictures.

**Snap** your fingers,

**Hiss** like a snake.

Don't **bang** the drum –

Baby will wake!

**Rattle** baby's rattle,

**Squeak** like a mouse.

I hear **footsteps**

Outside the house!

Please don't **whisper**,

You'll have to **shout**

It's very noisy,

School is out!

**Crackle** crisp packets,

**Pop** the balloon.

Ref. blows the **whistle**.

Football starts soon.



Lesson  
3a

## Light review

## Fact box

- Light travels at about 300,000 kilometres per second.
- Light travels in straight lines.
- When light goes from air into water or glass, it slows down. The light bends. This is called *refraction*.

## Aim

- To revise and extend scientific vocabulary to describe the properties of light.

## Language

- Dictionary definitions
- Vocabulary: *air, bend, glass, lens, light, opaque, ray, reflection, refraction, science, scientific, speed, straight, translucent, transparent, travel, water*

## Extra materials

- 1 copy of the Activity page per pair of pupils, Audio Tracks 54 & 55, Audio texts, IWB
- transparent, translucent and opaque materials, e.g. plastic cups; scissors; glue sticks; exercise books/paper; (if possible, scientific) dictionary; blue and red pencils; optional: mirror, lens, torch
- [www.bbc.co.uk/schools/scienceclips/ages/7\\_8/light\\_shadows.shtml](http://www.bbc.co.uk/schools/scienceclips/ages/7_8/light_shadows.shtml)

## Warm up

- 1 Before the lesson, write these groups of words on the board: *eye, light, to see, image, shadow, reflection, mirror/translucent, translucent, opaque*.
- 2 Explain that the pupils are going to find out how much they know about light. Introduce/Revise the nouns *eye, light, image, shadow, reflection* and the verb *to see*.
- 3 If possible, visit the website listed above.
- 4 Display the Audio text and read the words or play Audio Track 54. Pupils listen and follow, then join in.
- 5 Give 3 pupils a piece of transparent/translucent/opaque material. Reread the song, pausing after lines 2, 4 and 8 for the class to decide who has the right material to hold up to illustrate the words each time.
- 6 Sing the song again. Pupils display the materials as appropriate.

## Procedure

- 1 Show the class a page in a (scientific, if possible) dictionary. Point to the list of scientific words on the left and the *definitions* – or meanings – on the right.
- 2 Give out the Activity sheets and play Audio Track 55 or read the words for the pupils to follow and repeat.
- 3 Ask volunteer pairs to take turns to read a scientific word and its definition. Ask the class to put up a hand if they hear a scientific word not on the board (*sight, lens, refraction*). Explain any unfamiliar words.
- 4 Put the pupils in pairs to colour the words blue and the definitions red. Tell them to cut out the word boxes carefully and put the scientific words in one pile and the definitions in another, keeping them separate.
- 5 Pupil A reads a word aloud and Pupil B finds and reads its definition. Then pupils swap roles. If the answers are correct, the cards will fit together.

## Follow up

- 1 Put the class into two teams to play the game from the Activity sheet. Keep a score of correct answers to see which team wins. Make it fun.
- 2 Display the IWB. Explain that the pupils can use the information from the Activity sheet to complete the crossword.

## Useful websites (see also Extra materials above)

- [www.bbc.co.uk/learningzone/clips](http://www.bbc.co.uk/learningzone/clips)  
Type 1625, click *SEARCH* and watch the clip
- [www.bbc.co.uk/schools/scienceclips/ages/5\\_6/light\\_dark.shtml](http://www.bbc.co.uk/schools/scienceclips/ages/5_6/light_dark.shtml)
- [www.bbc.co.uk/schools/scienceclips/ages/10\\_11/see\\_things.shtml](http://www.bbc.co.uk/schools/scienceclips/ages/10_11/see_things.shtml)
- [www.engineeringinteract.org](http://www.engineeringinteract.org)  
Under *LIGHT*, click on *Launch yourself into Alien Attack!* and choose an activity
- [www2.bgfl.org/bgfl2/custom/resources\\_ftp/client\\_ftp/ks1/science/colour\\_and\\_light/index.cfm](http://www2.bgfl.org/bgfl2/custom/resources_ftp/client_ftp/ks1/science/colour_and_light/index.cfm)

Search terms: physical processes + light

## Cross curricular links

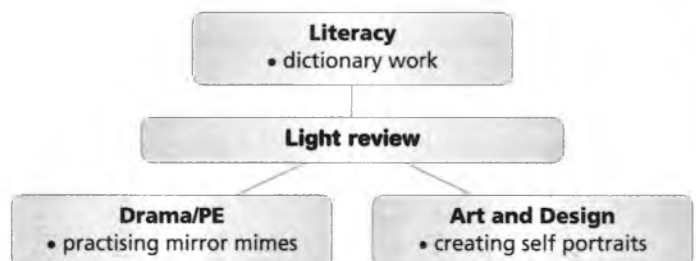

# Light review

T55

## Scientific words and dictionary definitions

Colour, cut out the words and mix them. Colour, cut out the definitions and mix them. Keep the piles separate. Work with a partner. Take turns to choose and read a word and find and read the definition. Do the 2 pieces fit?

eye

we use this to see

see

we do this with our eyes

light

opposite of dark

sight

sense using eyes

lens

in eyes, cameras, telescopes

shadow

there is not much light here

image

seen in a mirror

transparent

light goes through this

translucent

some light goes through this

opaque

no light goes through this

reflection

the image in a mirror

refraction

bending light

Lesson  
3b

## Sound: pitch

## Fact box

- The speed of sound in air is 343 metres per second.
- *Volume* is measured in decibels.
- The *pitch* of a sound is how high or low it is.
- The *shorter* the string or pipe, the *higher* the pitch.
- The *longer* the string or pipe, the *lower* the pitch.

## Aim

- To investigate how pitch is related to size in a musical instrument.

## Language

- Writing instructions
- Comparatives & superlatives: *higher, highest lower, lowest, longer, longest, shortest*
- Vocabulary: *fair test, instrument, musical, note, pipe, pitch, pluck, sound, stretch, string*

## Extra materials

- 1 copy of the Activity page per pupil, Audio Track 52 from Lesson 8.2b, Audio Track 56, IWB
- paper/exercise books, collection of boxes/cartons, elastic bands, sticky tape, scissors, optional: colour pictures of the musical instruments on the Activity sheet
- [www.bbc.co.uk/schools/scienceclips/ages/9\\_10/changing\\_sounds.shtml](http://www.bbc.co.uk/schools/scienceclips/ages/9_10/changing_sounds.shtml)

## Warm up

- 1 Play and join in Audio Track 52 from Lesson 8.2b. Revise the concepts of vibrations and volume.
- 2 Play the first 2 pitches of Audio Track 56. Ask how they are different. (One is a high sound; the other is low.) Explain *pitch*. Play the remaining sounds and ask the pupils to put up a hand when the pitch is low.
- 3 Explain that some musical instruments make higher pitched sounds than others.
- 4 If you have pictures, display and name them with the class, or give out the Activity sheets and tell the class to look at the pictures in activity 3. Ask what kind of sound each instrument produces – high or low pitch.

## Procedure

- 1 Give out the boxes/cartons, sticky tape and elastic bands.
- 2 Put the pupils in pairs and explain that they are going to make a simple musical instrument to see what sound it makes. Ask 5 pupils to read aloud the instructions for activity 1.
- 3 Allow 5 minutes for the pupils to make the instrument and then put the pairs into groups of 4 or 6 to find out which instrument has the lowest/highest pitch.
- 4 Ask the groups which instruments make the lowest pitched sounds and if they have the longest or the shortest strings (longest). Discuss if it is always true that the shortest strings have the lowest pitch (no).
- 5 Read activity 2 with the class. Tell the pupils to work in their pairs to write instructions (on the back of the Activity sheet) for the fair test. (Revise fair tests from Lesson 5.2b if needed.)
- 6 When the instructions are written they can be given to another pair to follow and record the results.

- 7 Introduce the word *note* – a musical sound. Discuss whether shorter or longer pipes have a higher or lower pitch before reading through and asking the pupils to answer the questions in activity 3.

## Follow up

- 1 Display the IWB for pupils to do the word search.
- 2 Challenge pupils to improve the sound of their instruments by cutting holes under the strings or by using a ruler as a bridge.
- 3 Visit the website listed above and do the activities.

## Useful websites (see also Extra materials above)

- [www.crick.northants.sch.uk/Flash%20Studio/cfsscience/sound1f/sound1f.html](http://www.crick.northants.sch.uk/Flash%20Studio/cfsscience/sound1f/sound1f.html)  
Hover over *Key Stage 1*, click *Science*, scroll down to *Sound*, click the picture
- [www.bbc.co.uk/learningzone/clips/](http://www.bbc.co.uk/learningzone/clips/)  
Type 1603, 2420, 2418 or 1608, click *SEARCH* and watch and listen to the clip

**Search terms:** sound + pitch, sounds activity, pied piper + story

## Cross curricular links

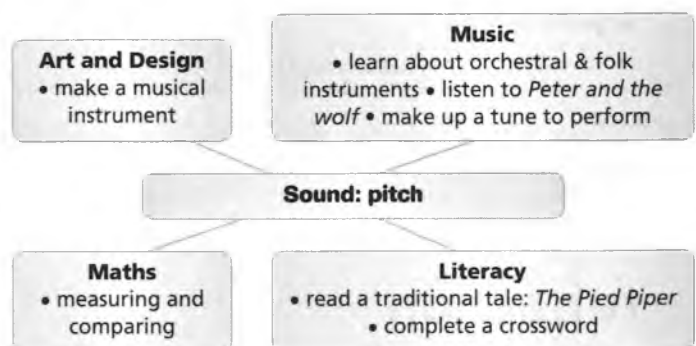

# Sound: pitch

## 1 Instructions to make a simple stringed instrument

### Equipment

1 box/carton      sticky tape      elastic band

### Method

- 1 Tape the box closed if necessary.
- 2 Stretch an elastic band over the box.
- 3 Hold the box with one hand.
- 4 Pluck the string (elastic band) with other hand.
- 5 To shorten the string, hold it down with one finger while plucking.

## 2 Write instructions

On the back of this sheet, write instructions for a fair test to see if long or short strings make high pitched sounds. (Remember: in a fair test, only one thing is changed and tested at a time.)

Draw a table for the results.

## 3 Answer these questions

1 Do long or short strings make the lowest notes? \_\_\_\_\_

2 Which instrument makes the high pitched notes? \_\_\_\_\_

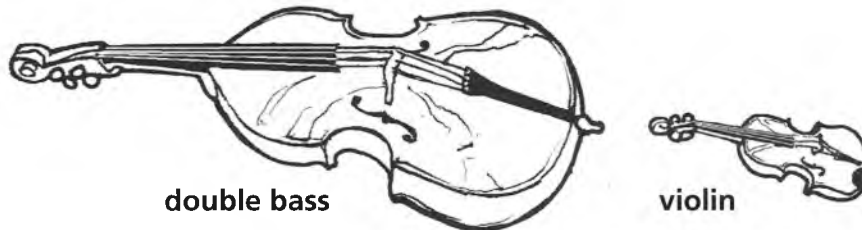

3 Which instrument makes the lowest notes? \_\_\_\_\_

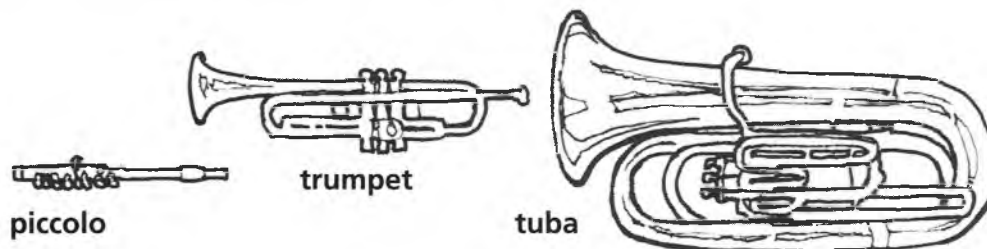

4 Which drum makes the lower notes? \_\_\_\_\_

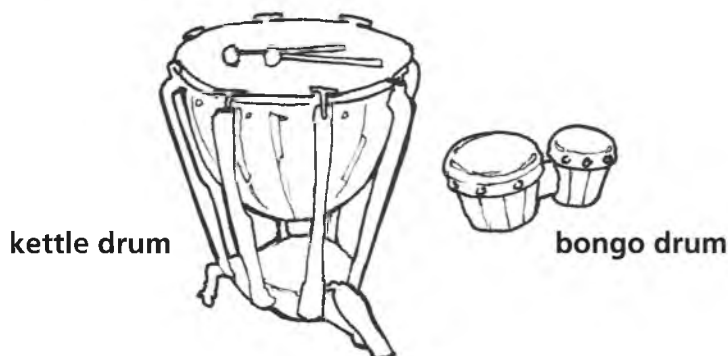

Lesson  
1a**Save – don't waste!****Fact box**

- A TV on standby uses 50 per cent of the electricity it uses when switched on.
- A dripping tap can waste up to 90 litres of water a day.
- You can turn water and electricity on and off.
- You can only use the verb *switch on/off* for electricity and light.

**Aim**

- To identify ways of conserving the Earth's resources.

**Language**

- Imperatives & contractions: *don't, can't, won't*
- Vocabulary: *bicycle, bucket, bus, computer, diesel, dripping, electricity, fuel, heater, light, off, petrol, save, switch, tap, teeth, turn, TV, waste, water*

**Extra materials**

- 1 copy of the Activity page per pupil, Audio Track 57, Audio text, IWB
- scissors, glue sticks, paper/exercise books

**Warm up**

- 1 Give out the Activity sheets and look at picture 1. Point out that the tap is dripping and wasting water. Ask what can be done. Write *I can turn off the tap* and *I can't turn off the tap* on the board. Ask how to save water if the tap won't turn off. Suggest that the water can be saved in a bucket.
- 2 Display the Audio text. Play Audio Track 57, verse 1. Ask pupils to listen and follow. Play and sing verse 1.
- 3 Look at picture 6 and ask if electricity can be saved in a bucket. Introduce the verb *to switch off/on*. Play the Audio, verse 2. Ask pupils to listen and follow. Play and sing verse 2.
- 4 Look at picture 3 and ask what the people are wasting (fuel/petrol/diesel). Ask how they can save fuel/petrol/diesel. Play the Audio, verse 3. Ask pupils to listen and follow. Play and sing verse 3.

**Procedure**

- 1 Read through the words on the Activity sheet with the class. Decide which word goes in the first box.
- 2 Put the pupils into pairs to discuss the pictures, decide on the missing words and match the words and pictures. Pupils write the missing words then either draw matching lines on the Activity sheet or cut and paste the matching words and pictures onto plain paper.
- 3 Check the answers with the class and then in different pairs. First, say the picture numbers and, after each number, choose a pupil to read the words that match that picture. Next, read the imperatives and after each one, choose a pupil to say the picture number that matches that imperative.

**Follow up**

- 1 Display the IWB for the pupils to do the word search.
- 2 Discuss why we need water, electricity and petrol/diesel and why it is good to save them.

- 3 Play and sing the song on the Audio right the way through with the class.
- 4 Discuss other ways in which people can save water, electricity and petrol or diesel.
- 5 Use the words of the song and the pupils' own drawings to make a poster.
- 6 Make *Don't waste!* posters to place by light switches and taps.

**Useful websites**

- [www.bbc.co.uk/schools/scienceclips](http://www.bbc.co.uk/schools/scienceclips)  
Click *Ages 6-7, Using electricity*
- [www.sciencemuseum.org.uk](http://www.sciencemuseum.org.uk)  
Click *Online stuff* then *Games* then *Energy flows*
- [www.sciencemuseum.org.uk](http://www.sciencemuseum.org.uk)  
Click *Online stuff*, then *Games*, then *Strange but true*

**Search terms:** eco schools, saving water (electricity, etc.) activities

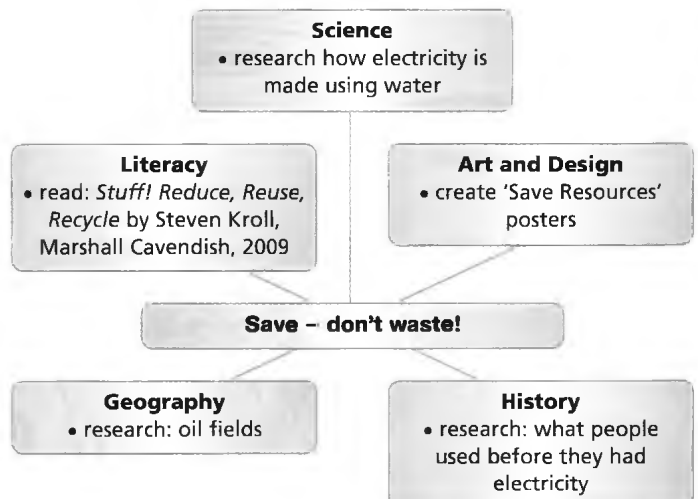
**Cross curricular links**

# Save – don't waste!

## Saving water, electricity and fuel

Write *water, electricity, or fuel*. Match the words and pictures.

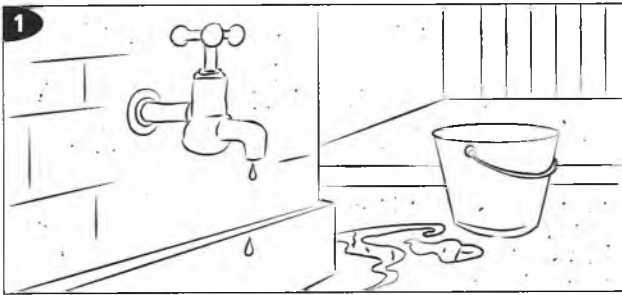

Save \_\_\_\_\_!

Turn off the computer when you have finished!



Save \_\_\_\_\_!

Turn off the tap! Never leave it dripping!

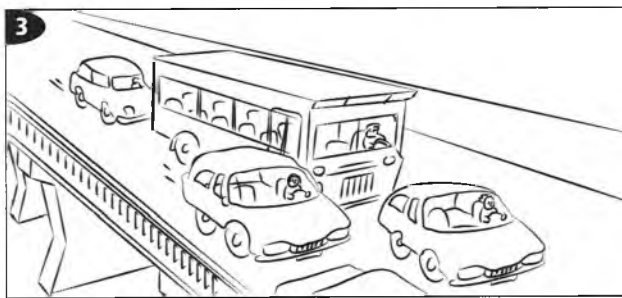

Save \_\_\_\_\_!

Turn off the lights and heater when you go out!

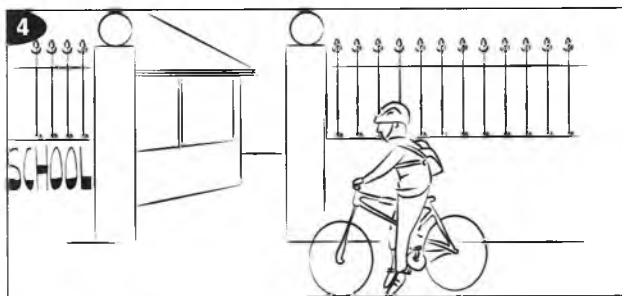

Save \_\_\_\_\_!

Go by bus or give your friend a lift!

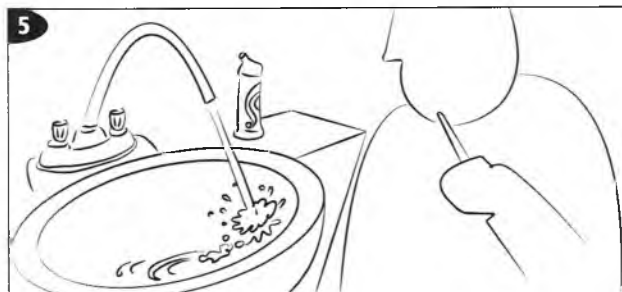

Save \_\_\_\_\_!

Ride a bicycle!



Save \_\_\_\_\_!

Turn off the tap while you clean your teeth!

Lesson  
1b

## Recycling

## Fact box

- Glass bottles can be melted to make new bottles.
- Metal cans are melted to make cars, cans, etc.
- Newspapers are made of recycled and new paper.
- Some thermoplastics can be recycled.
- Plastics are made from oil and can be burnt as fuel.

## Aim

- To identify items that can be recycled.

## Language

- Vocabulary: *bin, bottle, comic, factory, glass, jam, jar, litter, materials, metal, paper, plastic, recycle, rubbish, throw, toy*

## Extra materials

- 1 copy of the Activity page per pupil, Audio Tracks 58 & 59, Audio texts, IWB
- 1 die & 1 counter per pupil; used recyclable objects, e.g. plastic & glass bottles, drinks cans, newspaper

## Warm up

- 1 Hold up each recyclable object, name it and ask the pupils to repeat the words *glass bottle/jar*, etc.
- 2 Ask *What can be done with these things? Shall I throw them away or shall I recycle them?*
- 3 Give out the Activity sheets. Ask pupils to point to the pictures in activity 1 and repeat the words after you. Ask what will happen if the things are thrown in a *litter bin*. Follow the arrow from the litter bin and explain that they will go to a *rubbish dump*.
- 4 Point to and name the *recycle bin*. Ask what will happen if the things are put in this bin. Follow the arrow from the recycle bin and explain that they will go to a *recycling factory* where they will be *recycled* or made into new things.
- 5 Display the Audio text and play Audio Track 58. Tell the pupils to listen and follow the words. Play the song again and, this time, sing it with the pupils.

## Procedure

- 1 Ask the pupils to look at the game board in activity 2 on the Activity sheet. Play Audio Track 59 or read the words in the boxes. Ask the pupils to listen, repeat and point to the words and pictures.
- 2 Explain the game. Players (A and B) begin in opposite corners, taking turns to throw the die, move and read the words aloud. They look at the rubbish bag, recycling box or litter bin to find their score: recycling is worth 2 points, there are no points for putting recyclables in the litter bin, but putting litter in a bin is worth 1 point. There are some bonus points. Discuss why there are different scores for these actions.
- 3 Put the pupils into pairs and give out the dice and counters. Allow 5 minutes to play the game and remind the pupils to keep a note of their scores. When 5 minutes are up, the player with the highest score wins.

## Follow up

- 1 Play Audio Track 58 and sing the song again. Display the IWB for the pupils to complete the activity.
- 2 Discuss what happens to rubbish a) at home and b) at school, and how they can recycle more.
- 3 Find out where to recycle mobile phones, printer cartridges and batteries.
- 4 Collect and display labels with recycling symbols.
- 5 Find out what happens to recycled materials.

## Useful websites

- [www.bbc.co.uk/learningzone/clips](http://www.bbc.co.uk/learningzone/clips)  
Type 2470, 1576 or 9066, click *SEARCH* and watch the clip
- [www.planetpals.com/recyclefacts.html](http://www.planetpals.com/recyclefacts.html)
- [www.sciencemuseum.org.uk](http://www.sciencemuseum.org.uk)  
Click *Online stuff* then *Games* and scroll down and click *Wasted*

**Search terms:** recycling, reusing materials

## Cross curricular links

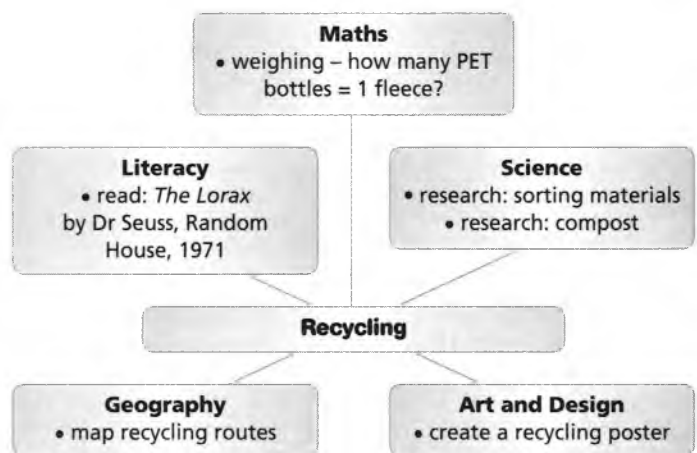

# Recycling

## 1 Where does the rubbish go?

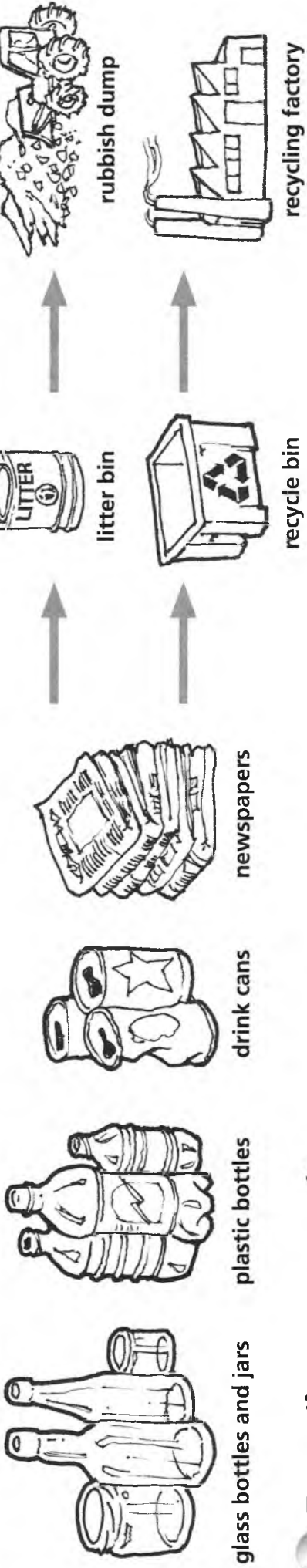

## 2 Recycling race track

<p><b>A</b> START →</p>	<p>Collect plastic bottles for recycling</p>	<p>Take glass bottles to bottle bank</p>	<p>Recycle newspapers</p>	<p>Throw drink can in litter bin</p>	<p>Recycle drink can</p>
<p>Give away old toys: +2 points</p>	<p>1 point</p>	<p>2 points</p>	<p>0 points</p>	<p>Throw comic in rubbish bag</p>	<p><b>B</b> START ←</p>
<p>Recycle jam jars</p>	<p>Give comic to a friend: +2 points</p>	<p>Throw glass jar in rubbish bag</p>	<p>Use old envelopes for shopping lists: +2 points</p>	<p>Leave plastic drink bottle in playground: -4 points</p>	<p>Leave plastic drink bottle in playground: -4 points</p>

Lesson  
2a

# Personal communication links

**Fact box**

- Rowland Hill invented postage stamps in 1840.
- Telephones were invented by Alexander Graham Bell in 1875.
- The first emails (electronic mails) were sent in the 1970s.
- Tim Berners-Lee invented the World Wide Web (www.) in 1990.
- The first small mobile phones were made in the 1990s.
- The first SMS text message was sent in 1993.

**Aims**

- To compare ways of communicating.
- To be able to select appropriate ways of communicating.

**Language**

- Vocabulary: *accident, ambulance, card, click, cursor, drag, letter, link, mobile phone, mouse, parcel, post, present, send, stamp, talk, telephone, text*

**Extra materials**

- 1 copy of the Activity page per pupil, Audio Tracks 60 & 61, Audio texts, IWB
- exercise books/paper, scissors, glue sticks, a postcard/letter in an envelope

**Warm up**

- 1 Show the postcard/letter. Tell the pupils where it was posted and ask how long they think it took to arrive.
- 2 Discuss other ways used by friends to share their news (telephone, mobile phone, text message, computer email message) and write them on the board.
- 3 Display the Audio text, play Audio Track 60. Tell pupils to listen and follow, then sing with the class.

**Procedure**

- 1 Give out the Activity sheets and see if pupils can read the text message in activity 1. Allow 1 or 2 pupils to write similar text messages on the board for the class to decipher.
- 2 Ask the class to look at the sentences in activity 2. Play Audio Track 61 or read sentences A to H to the class, pausing after each for the pupils to repeat and point to the words.
- 3 Read the first sentence again and ask which communication link the child can use to send the present to Australia. Ask which picture shows Granny with the parcel.
- 4 Look at picture 1. Ask how the man received the card and which sentence matches the picture.
- 5 Put the pupils into pairs to discuss each sentence and match it to a picture and a communication link.
- 6 Go through the answers with the class. Display the IWB for the pupils to complete the activities. Listen to Task 1 and use the information to answer Task 2.
- 7 Give out the exercise books/paper, scissors and glue sticks. Tell the pupils to cut out and glue the matching sentences, pictures and links onto paper.

**Follow up**

- 1 Replay Audio Track 60 and sing the song with the class again.
- 2 Research costs and time taken for a letter/parcel/email/text to be delivered.
- 3 Write letters, emails and texts to another school.
- 4 Find out about blogs, twitters and social networks.

**Useful websites**

- [www.bbc.co.uk/learningzone/clips](http://www.bbc.co.uk/learningzone/clips)  
Type 6131, 4381 or 7147, click SEARCH and watch the clip
- [www.thinkuknow.co.uk/5\\_7/hectorsworld](http://www.thinkuknow.co.uk/5_7/hectorsworld)  
Watch cartoons about using computers safely
- [www.disney.co.uk/DisneyOnline/Safesurfing/main.html](http://www.disney.co.uk/DisneyOnline/Safesurfing/main.html)  
Activities and information about safe surfing

**Search terms:** letter writing + school

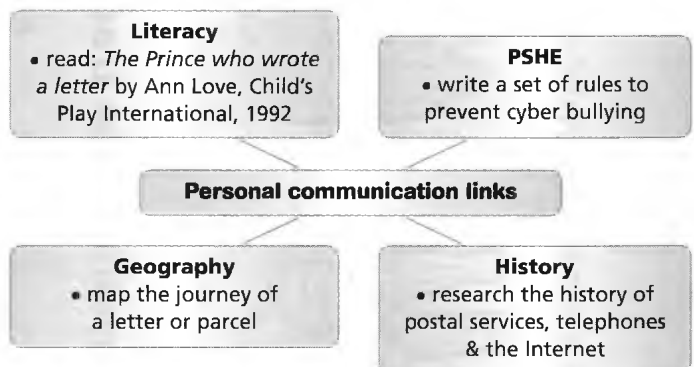
**Cross curricular links**

# Personal communication links

## 1 Can you read this text?



## 2 T61 Thinking of you

- A** How can I send the present I made to my Granny in Australia?
- B** I want to talk to my friend who has gone to live in America.
- C** We need to tell Mum something but she is at work and cannot talk.
- D** My dad is working in England. I want to send him the card I made.

- E** How can I show this photo to my granddad? He lives a long way from here.
- F** I have written a story. I want all my friends to read it.
- G** How can I hear your news when I don't know where you are?
- H** There has been an accident. I need to call an ambulance.

1

Look at this lovely card!

2

Have you read this funny story?

3

I have a text so I know they are OK.

4

What a lovely birthday present!

5

I like it here but I miss my friends.

6

Come and see this photo.

7

I've just climbed a mountain.

8

Where shall I send the ambulance?

webcam + computer

parcel post

Internet

text

letter post

mobile phone

email

telephone

Lesson  
2b

## Global communications

## Fact box

- Tim Berners-Lee invented the World Wide Web (www.) in 1990.
- Blogs (web logs) date from 1997 and Twitter from 2006.

## Aim

- To investigate different means of global communication and to identify facts and opinions in news reports.

## Language

- Fact and opinion
- Vocabulary: *blog, computer, erupt, eye witness, fact, instant, internet, mobile phone, newspaper, opinion, radio, reporter, television, today, trust, twitter, volcano, website, world, yesterday*

## Extra materials

- 1 copy of the Activity page per pupil, Audio Tracks 62 & 63, IWB
- a newspaper, scissors, glue sticks

## Warm up

- 1 Give out the Activity sheets and look at the pictures in activity 1. Read the media names in the text boxes. Ask the pupils to listen and repeat the nouns after you.
- 2 Ask if newspaper stories are about what is happening today or about what happened yesterday.
- 3 Ask the class how to find out about what is happening today. List the pupils' suggestions on the board.

## Procedure

- 1 With the class, discuss the differences in the way the news is told in newspapers and on the television. Explain that newspaper stories are about things that happened yesterday, but that some of the news reported on the TV, radio or Internet may be happening now.
- 2 Explain and discuss the difference between facts and opinions (see 4.3b). Explain that a blog or twitter is usually someone's opinion about something.
- 3 Play Audio Track 62 or read the speech bubbles and text sentences from activity 1, pausing after each one for the pupils to identify and repeat the words.
- 4 Ask questions about the different reports to check the pupils' understanding. Explain that an eye witness is someone who was there at an incident and saw what was happening.
- 5 Display the IWB for the pupils to complete the activity.
- 6 Give out the scissors and glue sticks. Look at activity 1 on the Activity sheet. Tell the pupils to cut and paste the media names into the top row of boxes and the speech bubbles/words into the bottom row, matching the pictures each time. Check the answers again with the class.
- 7 Ask the pupils to listen and follow the discussion questions in activity 2. Play Audio Track 63 or read the questions to the class. Check the pupils' comprehension.

- 8 Put them into pairs or groups to talk about and write an answer to one (or more) of the questions.
- 9 Ask the pairs/groups to share their answer(s) with the class. Encourage class discussion of their answers.

## Follow up

- 1 Practise writing news items about the same topic in different styles.
- 2 Make a class newspaper and video a class news programme.
- 3 Look at a news item in a newspaper. List the facts and the opinions.

## Useful websites

- [www.bbc.co.uk/schools/ks2bitesize/english/reading](http://www.bbc.co.uk/schools/ks2bitesize/english/reading)  
Go to *Deduction*, click *Read* then *Newspaper reports and adverts*
- [www.bbc.co.uk/schools/ks2bitesize/english/writing](http://www.bbc.co.uk/schools/ks2bitesize/english/writing)  
Go to *Argument*, click *Play* or *Read*

**Search terms:** writing + school, global schools, history of the post

## Cross curricular links

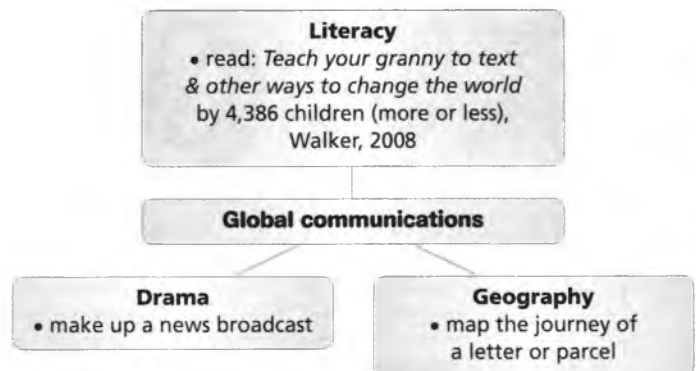





# Global communication

## 1 T62 Here is the news

Match the media and the words to the pictures.

- Internet
- mobile phone
- radio
- television
- newspaper

<b>1</b>	<p>Hi, Mum. You can see the volcano erupting now.</p>	<b>3</b>	<p>The volcano began to erupt early yesterday morning. This photo, taken on a mobile phone by an eye witness, shows</p>
<b>2</b>	<p>The volcano began to erupt at about six o'clock this morning</p>	<b>4</b>	<p>This is the seven o'clock news. Here is our reporter who is at the scene.</p>
<b>5</b>	<p>The Government should have warned us that the volcano was going to erupt.</p>		

<b>A</b>	<b>B</b>	<b>C</b>	<b>D</b>
			
<b>E</b>			
			

## 2 T63 Something to talk about!

How do we know what is happening in our town?

How do we know what is happening in our world?

How do we know what is happening in our country?

How do we know these things are true?

Can we trust the reporters?

Lesson  
3a

# Carbon footprint

## Fact box

- **Carbon dioxide** = CO<sub>2</sub>.
- **Carbon footprint** = carbon dioxide emissions measured in kg.
- Growing, manufacturing, transporting and storing products leave footprints.
- Leaving one computer on 24 hours a day = 600kg CO<sub>2</sub> emissions a year.
- Humans breathe out CO<sub>2</sub>.
- Plants take in CO<sub>2</sub> and change it to oxygen and carbon
- Methane (CH<sub>4</sub>) is also a greenhouse gas. Cows burp methane!

## Aim

- To identify ways in which individuals can make lifestyle changes which will reduce their impact on the Earth's resources.

## Language

- Vocabulary: *air, carbon, carbon dioxide, CO<sub>2</sub>, electricity, emission, environment, footprint, fossil fuel, gas, greenhouse, heating, methane, transport*

## Extra materials

- 1 copy of the Activity page per pupil, Audio Track 64, IWB
- a ruler, a footprint on a piece of paper, labelled

## Warm up

- 1 Show the footprint. Say *This is a footprint*. Pupils repeat.
- 2 Say, and demonstrate: *I can measure the footprint with a ruler*.
- 3 Ask if the pupils have heard of a *carbon footprint*.
- 4 Give out the Activity sheets and look at the pictures at the top. Explain that each time we use electricity or burn fossil fuels like coal and oil, and every time we travel in a car, bus or plane, a gas called carbon dioxide is given off and our carbon footprint grows bigger.

## Procedure

- 1 Explain that a carbon footprint cannot be measured with a ruler, but we can work out how many kilograms of carbon dioxide we put into the air.
- 2 Write *carbon dioxide* and CO<sub>2</sub> on the board. Explain that the amount of CO<sub>2</sub> in the air is increasing which is not good for Earth. We need to think about things we do that increase our carbon footprints and then make choices about things we can do to make less CO<sub>2</sub> and so make smaller carbon footprints.
- 3 Play Audio Track 64 or read the choices on the Activity sheet. Pause after each choice to repeat and discuss.
- 4 Tell the pupils to choose and write 5 (or more) ways to make their own carbon footprints smaller.

## Follow up

- 1 Ask individual pupils to read out the choices they have made.
- 2 Ask for more ideas to add to the footprint chart.
- 3 Display the IWB for pupils to complete the activity.
- 4 Cut out the pupils' footprints and use them to make a classroom display.

## Useful websites

- [www.scholastic.co.uk/eco-island](http://www.scholastic.co.uk/eco-island)  
Go to and click the activity of your choice
- [www.globalfootprints.org/teachers](http://www.globalfootprints.org/teachers)  
Scroll down and click *Our Kids Quiz*
- [www.sciencemuseum.org.uk](http://www.sciencemuseum.org.uk)  
Click *Online stuff* then *Games* then *Energy ninjas* or *Hungry mice*
- [www.climatechoices.co.uk](http://www.climatechoices.co.uk)  
Click *resources* or *activities*
- [www.naturegrid.org.uk/eco-exp](http://www.naturegrid.org.uk/eco-exp)  
Click on *Eco-centre*

**Search terms:** eco school, carbon footprint, renewable energy

## Cross curricular links

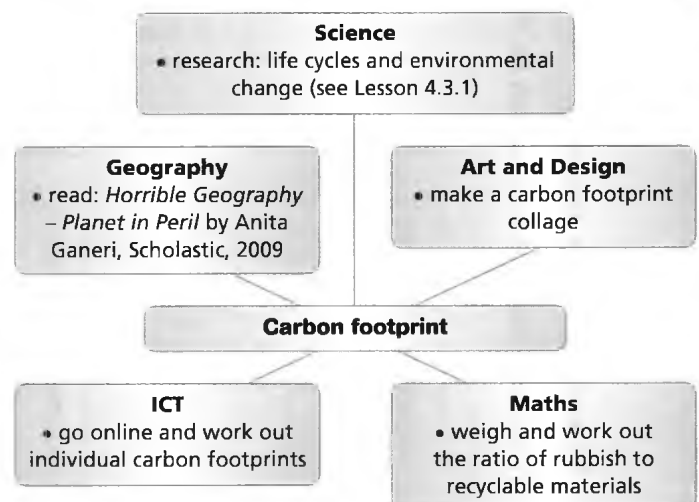



Lesson  
3b

## Helping the Earth

## Fact box

- An estimated 50% of the world's rain forests have been cut down since 1950.
- Fair Trade offers farmers a fair price for their products.
- Charities such as The Red Cross provide emergency aid when there is a disaster.

## Aims

- To understand that everyone is part of a global community.
- To discuss how individual actions can affect the Earth.

## Language

- Imperatives: verbs
- Vocabulary: *bicycle, charity, communicate, community, computer, Earth, electricity, email, factory, global, recycle, resources, rubbish, traffic, waste, water*

## Extra materials

- 1 copy of the Activity page per pupil (enlarged if possible), Audio Track 65, IWB
- scissors, dice and counters for the board game

## Warm up

- 1 Write the class name at the top of the board. Ask different pupils each to write on a new line, the name of the school, street, town, district, country, continent, Earth, and the Universe as if addressing an envelope.
- 2 Explain that we are part of the *global community* living on the Earth and we all use the Earth's resources.
- 3 Ask the pupils to name any of Earth's resources (water, oil, gas, electricity, trees, etc). List the answers on the board.
- 4 Ask when water is used (drinking, washing, cooking, making things in factories) and when oil is used (to run cars, buses, aeroplanes, in factories). Discuss what can be done so that these resources are not wasted.

## Procedure

- 1 Put the pupils in pairs. Give out the Activity sheets and scissors. Explain that there are 2 games.
- 2 For game 1, Bingo, pairs cut out all the cards on one sheet. The other sheet is the game board. Pairs turn the cards face down (except the 2 blank cards) and mix them up, then take 11 cards each and look at the words and pictures. Play Audio Track 65 or read out the words in the boxes at random. The player with the same words puts that card on top of the matching words on the board. The first person to put down all their cards shouts *Bingo!*
- 3 Challenge each pupil to think of one thing to do at home to help the Earth (e.g. feed the birds, make compost). Tell the pairs to write their ideas on the 2 blank squares on the board (2, 24) and on the 2 blank cards and discuss how many points the actions are worth. Play the game again.
- 4 For game 2, Match and score, pairs turn all 24 cards face down and mix them up. They take turns to pick up a card, read the words aloud, match the picture to the one on the board and write down the score.

## Follow up

- 1 Choose pupils to read out some cards. Ask the rest to raise a hand when they hear a verb. List the answers.
- 2 Talk about the actions. Discuss which are 'odd ones out' and how not smoking or not taking drugs can help the community. Ask how communicating by letters or texts helps the community.
- 3 Write persuasive newspaper articles about these issues.
- 4 Display the IWB for pupils to complete the activity. Explain that pupils will get a higher score if they highlight each answer correctly first time.

## Useful websites

- [www.globalfootprints.org/teachers](http://www.globalfootprints.org/teachers)  
Scroll down to and click *Our Kids Quiz*
- [www.bbc.co.uk/schools/ks2bitesize/english/writing](http://www.bbc.co.uk/schools/ks2bitesize/english/writing)  
Go to *Argument*, click *Play or Read*
- [www.sciencemuseum.org.uk](http://www.sciencemuseum.org.uk)  
Click *Online stuff* then *Games*. Go to and click *Building bonanza*

**Search terms:** global community, global schools, eco-friendly

## Cross curricular links

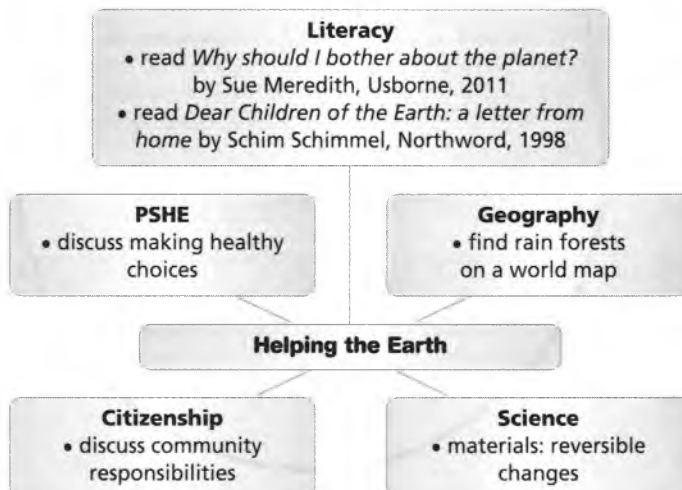

1



Recycle  
+ 2 points

2



One computer  
switched on 24/7 emits  
600 kg CO<sub>2</sub> in a year.  
Switch off.  
+ 3 points

4



+ 5 bonus points

5



A dripping tap can  
waste 90 litres of water  
a day! Turn it off.  
+ 5 points

6



Say **No** to smoking.  
+ 10 points

7

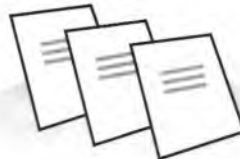

Don't waste paper.  
+ 3 points

8



Support a charity.  
+ 4 points

9



Never leave litter!  
+ 3 points

10



Buy a bar of  
Fair Trade chocolate.  
+ 3 points

11



Use energy-saving  
light bulbs.  
+ 2 points

12



Ride a bicycle.  
+ 3 points

13



50% of rainforests  
have been cut down  
since 1950. Plant a tree.  
+ 5 points

14



Communicate!  
Send a card to a  
friend far away.  
+ 1 point

15



Sit in a traffic jam.  
0 points

16



Throw away  
less rubbish.  
+ 3 points

17



Say **No** to drugs!  
+ 10 bonus points!

18



Communicate!  
Send a text.  
+ 1 point

19



Walk.  
+ 3 points

20



Go by bus.  
+ 2 points

21



A TV on standby  
uses 50% electricity.  
Switch off.  
+ 3 points

22



Go on line. Find a  
useful website.  
+ 1 point

23



Communicate!  
Send an e-mail.  
+ 1 point

24

Lesson  
1a

## The water cycle

## Fact box

Water on the Earth is always moving. It moves in a circle called *the water cycle*.

- First, the sun *heats* the water in rivers and lakes and in the sea. The water *evaporates* into the air.
- Next, the water *vapour cools* and *condenses* into *clouds*.
- Then, clouds move up over the land and water *falls* as rain.
- Finally, the rain water *collects* in lakes and rivers which take it back to the sea. The cycle starts again.

## Aims

- To be able to identify and sequence the key components of the water cycle.

## Language

- Time markers: *First, next, then, finally*
- Nouns: *cloud, vapour, water cycle*
- Verbs: *condenses, cools, evaporates, falls, heats, returns*

## Extra materials

- 1 copy of the Activity page per pupil, Audio Track 66, 1 copy of the Audio text per pair of pupils, IWB
- scissors

## Warm up

- 1 Ask *Where does water come from? Where does the water go when it rains?*
- 2 Display the Audio text. Play Audio Track 66 and ask the class to listen and follow the words.
- 3 Read the words with the class. Play the Audio again. Ask the pupils to clap the rhythm as they say the words.
- 4 Tell the pupils to stand up and do actions as they say the poem. Line 1: draw circles in the air; line 2: wave hands and fingers upwards; lines 3 & 4: jump up into the air; lines 5 & 6: wave arms like clouds; lines 7 & 8: shout *Hurray!*; line 9: wave hands and fingers downwards, shiver and look cold; line 10: move hands to show the water swelling; line 11: make sea wave movements with hands; line 12: do water ski movements.
- 5 Put the pupils into pairs and give out the poem words and scissors. Tell each pair to cut the poem into 6 pairs of lines and then mix the lines up. Give them 2 or 3 minutes to put the lines back in the correct order.

the right order. If they turn over a picture out of order, they put it back and wait until the next go.

- 6 Tell them to say what is happening on the card when they turn it over, e.g. *The water is evaporating and to try to remember which stage of the cycle comes next. They can look at the diagram to remind them.*

## Follow up

- 1 Display the IWB for the pupils to complete the activity.
- 2 Read *Mr Gumpy's Outing* by John Burningham with the class. Talk about different ways of asking for permission. If there is time, use the story for a role play exercise. Discuss the dangers of being unable to swim. Explain that the story has a happy ending. Ask if they know any other stories with a happy ending.

## Useful websites

- [topicbox.net/Geography/Water%20Cycle](http://topicbox.net/Geography/Water%20Cycle)  
Click *Water Cycle* (row 3) and choose an activity
- [www.bbc.co.uk/schools/riversandcoasts/water\\_cycle](http://www.bbc.co.uk/schools/riversandcoasts/water_cycle)  
Click *Rivers* or *Coasts*
- [www.globaleye.org.uk/primary\\_summer2002/focuson/index.html](http://www.globaleye.org.uk/primary_summer2002/focuson/index.html)

**Search term:** the water cycle

## Cross curricular links

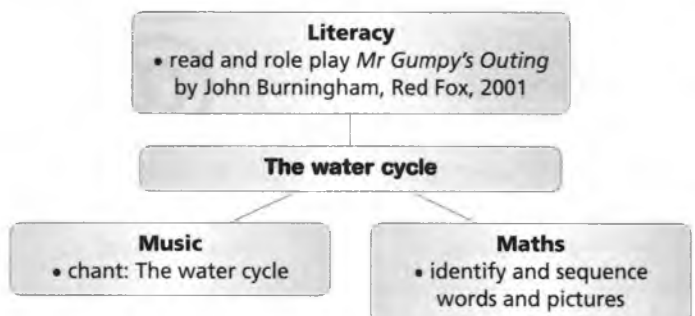

## Procedure

- 1 Give out the Activity sheets and look at activity 1.
- 2 Remind the pupils of the chant and, using the diagram and Fact box information, explain the water cycle.
- 3 Write the key words and any others they may not understand on the board and explain them.
- 4 Read the 4 stages in activity 2. Explain that they are not in order. Ask *What happens to the water first/next/then/finally?* Tell pupils to number the stages, 1 to 4, cut them out and stick them on the diagram in activity 1.
- 5 Put the pupils into pairs. Ask them to cut out the pictures in activity 2, mix them up and spread them, face down, on the table for the water cycle game. Pupils take turns to pick up a card and make a set of the 4 stages in

# The water cycle

## 1 Label the water cycle

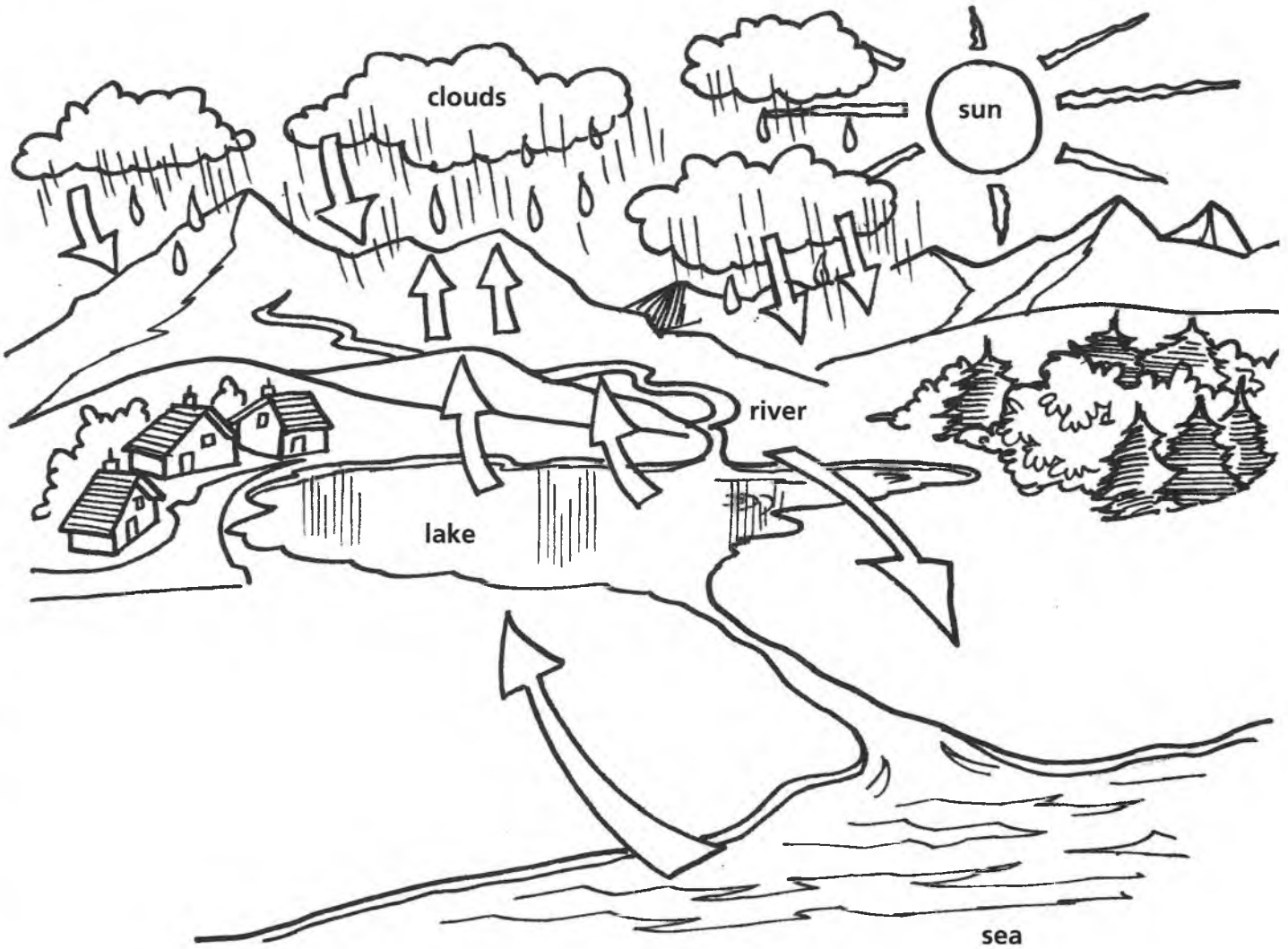

## 2 Number, cut out and play

<p>clouds</p>	<p>river</p> <p>lake</p> <p>sea</p>	<p>lake</p>	<p>clouds</p>
<p>water vapour condenses into clouds</p>	<p>water returns to the sea</p>	<p>water evaporates into the air</p>	<p>water falls as rain</p>

Lesson  
1b

# Where does the water go?

## Rain and puddles

### Fact box

- **Evaporation** occurs when water is heated and turns to vapour.
- **Condensation** occurs when the vapour cools and changes back to a liquid.

### Aims

- To understand the importance of water conservation.
- To understand the processes of evaporation and condensation.

### Language

- Look at Lesson 9.1a and revise language from Lesson 10.1a
- Vocabulary: *condensation, cools, evaporation, heats, vapour*

### Extra materials

- 1 copy of the Activity page per pupil, Audio Track 66 from Lesson 10.1a, IWB
- chalk, clear plastic jug of ice-cold water, blue coloured pencils

### Warm up

- 1 If possible, at the start of the day when sunny, take the class outside to look at puddles. (If there are none, make some with tap water.) Ask the class to find one in the sun and one in the shade. Draw round the edge of each puddle with chalk. Tell the pupils they will look later to see if the puddles have changed. Later, compare the water in each puddle. Ask *Which puddle has least water? Where does the water go?*
- 2 Play Audio Track 66 from Lesson 10.1a and say the poem again. Talk about how the sun heats the water and turns it into vapour or steam (as in a kettle). The vapour leaves the puddle and goes into the air. This is called *evaporation*.

### Procedure

- 1 Display the IWB for the pupils to do the activity.
- 2 Give out the Activity sheets and blue pencils. Look at activity 1. Explain that it is the same experiment. Read the words and tell the pupils to draw the water in the saucers and use the words to write sentences about what happened. Put pupils into pairs to read their sentences. Ask some pupils to read to the class. Tell pupils to do the experiment at home and time how long it takes for the water to evaporate.
- 3 Show the jug of ice-cold water. Leave it to stand in the warm room. After a few minutes, ask the pupils to look at the jug and say what they can see on the outside (water droplets). Explain that the water didn't come from inside the jug; it came from the air. When the water vapour in the warm air touched the cold jug, it turned back to liquid. This is called *condensation*. Explain that this is how clouds form in the sky: when water vapour in warm air cools, it turns back to water droplets which collect and form into clouds.
- 4 Look at activity 2. Read the words and tell the pupils to draw the water in/on the jug and use the words to write what happened to the water. Put the pupils into pairs to read their sentences. Ask some pupils to read to the class. Tell pupils to do the experiment at home and time how long it takes for the water to condense.

### Follow up

- 1 Talk about why water is important and why/when we need to save water. Ask *How can we save water?*
- 2 Look at activity 3. Tell the pupils to look at what each person in the pictures is doing. Ask how the pictures are different. Ask *Which family is saving water?*
- 3 For homework, ask the pupils to notice how much water they use for different activities, e.g. washing, brushing teeth, etc. Tell them to write down all the ways they can think of to save water.

### Useful websites

- [www.primaryresources.co.uk/science/pdfs/RDevap.pdf](http://www.primaryresources.co.uk/science/pdfs/RDevap.pdf)
- [www.kidzone.ws/water](http://www.kidzone.ws/water)

**Search terms:** evaporation, condensation

### Cross curricular links

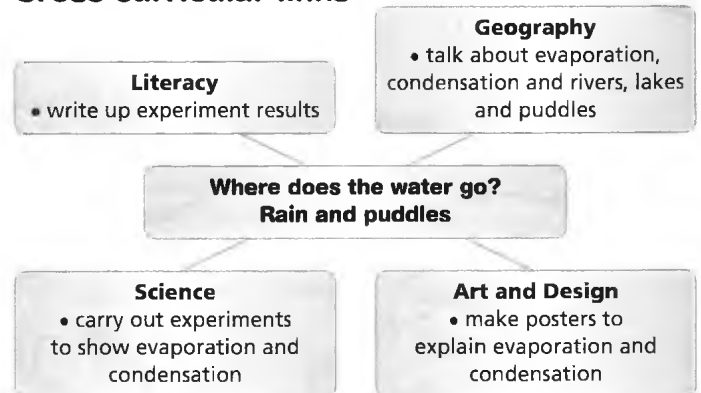





# Where does the water go?

## Rain and puddles

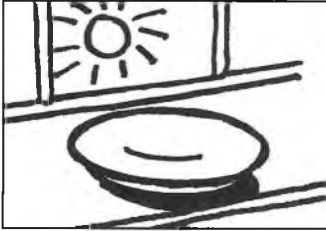
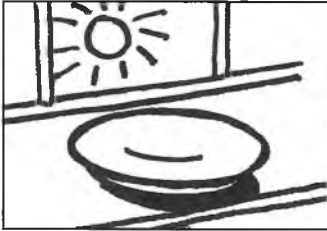
### 1 Evaporation. Draw and write

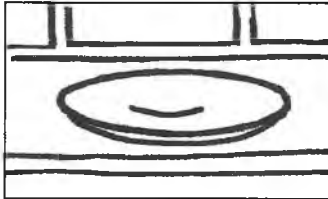

saucer evaporate vapour heats

	start	after 2 hours	after 1 day
saucer in the sun:			
saucer in the shade:			

At the start, the water \_\_\_\_\_  
 After two hours, the water \_\_\_\_\_  
 After one day, there was \_\_\_\_\_ water left in \_\_\_\_\_



### 2 Condensation. Draw and write

glass cold warm water droplets condense vapour

start	after a few minutes
	

At the start, \_\_\_\_\_  
 After one day, \_\_\_\_\_

### 3 Spot the difference. Which family is saving water?

<p><b>A</b></p> 	<p><b>B</b></p> 
---	--

Lesson  
2a

# What's the weather like?

**Fact box**

- Weather patterns are caused by changes in the air pressure.
- Storms, thunder and lightning, cyclones, and hurricanes are extreme weather conditions and can do a lot of damage. They bring high winds and floods.
- Extreme weather is sometimes due to climate change.
- Droughts are caused by a long time with no rain. This can cause plants to die and people and animals to starve and die.

**Aims**

- To develop understanding of local and wider weather patterns.
- To understand that extreme weather is sometimes due to climate change.

**Language**

- Adjectives: *breezy, cloudy, cold, cool, foggy, hot, icy, rainy, snowy, sunny, warm, windy*
- Nouns: *air pressure, cyclone, drought, flood, hurricane, lightning, rainfall, speed, storm, temperature, thunder, wind*

**Extra materials**

- 1 Activity sheet per pupil, Audio Tracks 67 & 68, Audio texts, IWB
- a world map; (optional) weather instruments: thermometer, rain gauge, wind sock, weather vane, barometer

**Warm up**

- 1 Display Audio text and play Audio Track 67. Teach the chant in the usual way. Ask pupils to stand and say the words with actions. (Line 1: hold up right hand; 2: hold left hand over right; 3: wiggle fingers; 4: spread wiggling hands out; 5: move both hands to right; 6: make arc over head with hand.)
- 2 Discuss the weather today and how weather forecasts are made.
- 3 If you have one available, look at the world map (or use the map in 10.2b) and ask a pupil to find and point to the British Isles.

**Procedure**

- 1 Give out the Activity sheets. Look at activity 1. Read the country, capital city and weather words.
- 2 Play Audio Track 68. Tell pupils to look at the map. Point to the areas and symbols as they are mentioned. Ask pupils to describe the weather in each area.
- 3 Display the IWB for the pupils to complete the British Isles activity.
- 4 Look at the map in activity 2. Pupils draw weather symbols to make their own weather map for the UK.
- 5 Put the pupils into pairs to give a weather forecast from their map, e.g. *Today the weather is ... over Edinburgh. It is ...*. Choose pupils to read their weather forecast to the class.
- 6 Talk about how world climate is changing and what is causing it. Explain *cyclone, hurricane, flood* and *drought* and show the symbol for each. Explain that these have always happened in some areas of the world but that with changing climate patterns, they happen more often. Ask if they occur in their own country.

- 7 Tell the pupils to look outside. Ask *Which symbols can you use for the weather today? If you have a thermometer, ask What is the temperature today? Ask How much rainfall is there? From which direction is the wind blowing? How strong is it?* Discuss how we record temperature, rainfall and wind speed.
- 8 Display and talk about the pictures of weather instruments.
- 9 Look at activity 3. Tell pupils to complete the chart for today and fill in the rest at school or for homework.

**Follow up**

- 1 Tell pupils to look at and listen to weather forecasts for their own country.
- 2 Make a weather forecast for their area using a local map. Choose pupils to read their forecast to the class.

**Useful websites**

- [teacher.scholastic.com/activities/wwatch](http://teacher.scholastic.com/activities/wwatch)
- [www.field-studies-council.org/documents/centres/brockhole/climatechangeresources/ks2/Chapter%201.pdf](http://www.field-studies-council.org/documents/centres/brockhole/climatechangeresources/ks2/Chapter%201.pdf)

**Search terms:** weather, weather forecasts, climate change

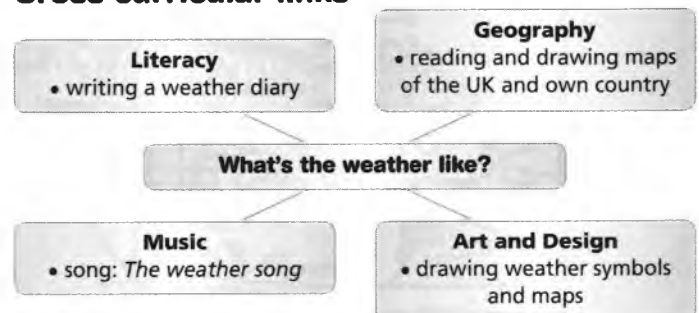
**Cross curricular links**

# What's the weather like?

## 1 T68 Read a weather map

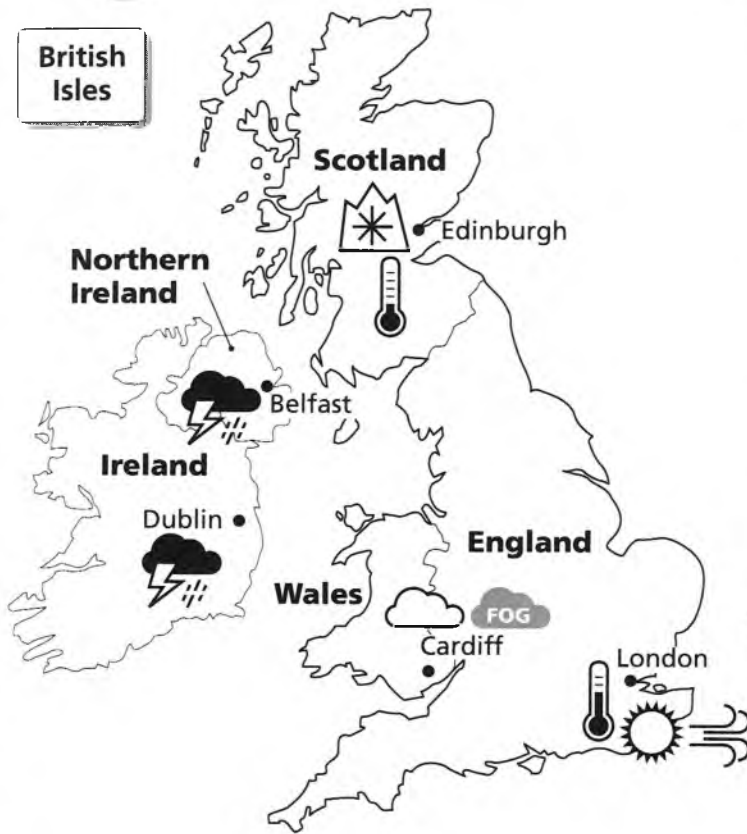

## 2 Make a weather map

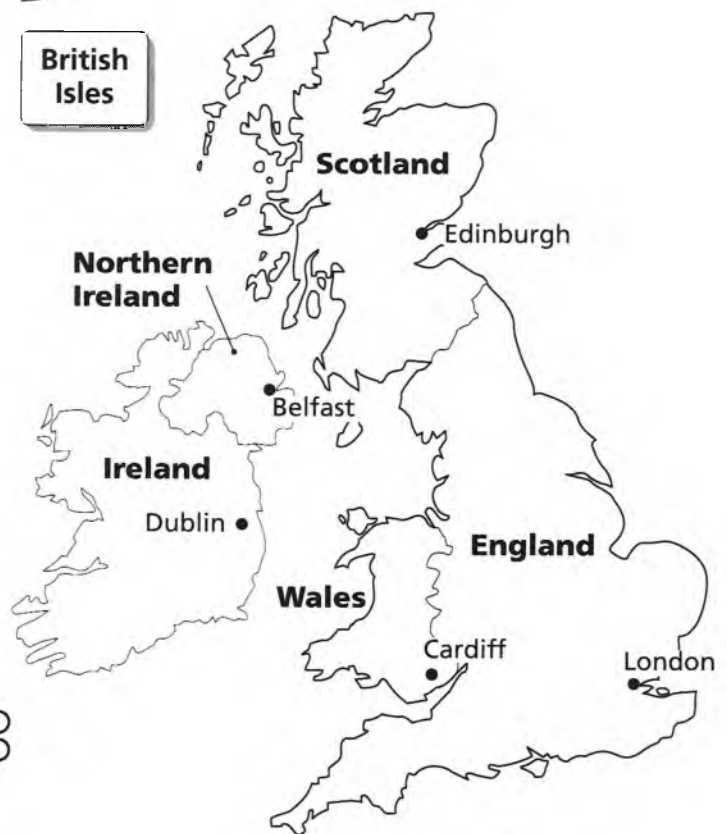

rainy windy breezy sunny cloudy snowy icy foggy  
hot cold warm cool storms thunder lightning

## 3 Make your own weather diary

	weather symbols	temperature	wind strength	wind direction	rain
Monday					
Tuesday					
Wednesday					
Thursday					
Friday					
Saturday					
Sunday					

# How does the weather affect us?

## Fact box

- When the weather changes, humans and animals adapt by finding ways to keep their bodies at the correct temperature.
- In winter, we wear warmer clothes and we heat our houses. Animals grow thicker coats and some sleep until it is warmer again.
- In summer, we wear thinner clothes and cool our houses. Animals find cooler places to live.

## Aims

- To recognise different climatic zones.
- To understand how varying weather conditions affect or change the landscape and its inhabitants.

## Language

- Revise seasons from Lesson 6.2a, climate from Lesson 6.2b, weather from Lesson 10.2a

## Extra materials

- 1 copy of the Activity page per pupil, IWB
- [www.bbc.co.uk/learningzone/clips/climate-zones-across-the-globe/11182.html](http://www.bbc.co.uk/learningzone/clips/climate-zones-across-the-globe/11182.html)
- coloured pencils, 1 sheet of poster paper per group, glue sticks, scissors, magazines, paper for postcards

## Warm up

- 1 Visit the website listed above. Watch and listen to the clip with the class.
- 2 Give out the Activity sheets. Look at the world map in activity 1. Ask the class to name any countries they know/places they go for holidays. Ask *Do you go to hot or cold places?* Discuss what they do in high/low temperatures. Discuss how the climate affects how we live and what we do (e.g. keeping ourselves *warm/cool*; *heating/cooling* our houses). Talk about how the climate is changing and how people and animals adapt. Mention the melting polar caps, droughts, flooding and hurricanes.
- 3 Ask *Which are the hot/warm/cold/cool countries?* List them on the board. Teach climate zones.
- 4 Tell the pupils to colour the countries: hot = red, warm = orange, cold = blue, cool = green.

## Procedure

- 1 Discuss weather changes in one place through the year: why it gets colder in autumn/winter and hotter in spring/summer. Ask *What do we do when the weather gets hotter/colder?*
- 2 Look at activity 2. Tell the pupils they are going to use the Venn diagram to compare what they do in winter and in summer. Ask them what they do in winter/summer. Make lists on the board. Ask *How are the winter and summer things different? Is the weather different? Do you wear thicker/thinner clothes? What do you do that is the same in winter and summer? Is the weather the same?*
- 3 Put the pupils into small groups and give out the poster paper and magazines. Tell them to write *Things we do in ...* at the top and copy the Venn diagram to fill the space. Tell them to draw/write/stick winter things on the left, summer things on the right and things they do in both winter and summer in the overlap.

- 4 Ask each group to count how many things are different and how many things are the same on their poster.
- 5 Ask groups to show their posters. Pupils ask *How many things have you got that are different/the same?*

## Follow up

- 1 Display the IWB for the pupils to complete the activity.
- 2 Ask the pupils to choose a place with a different climate from their own. Read the questions in activity 3 then ask pupils to find the answers for their place. Give out the paper. Tell pupils to write a postcard as if from their place. They must write where they are, what the weather is like, what they did and ate there.
- 3 When they have finished, choose pupils to read their postcards to the class.

## Useful websites (see also Extra materials above)

- [teacher.scholastic.com/activities/wwatch](http://teacher.scholastic.com/activities/wwatch)
- [www.factmonster.com/dk/encyclopedia/climate-zones.html](http://www.factmonster.com/dk/encyclopedia/climate-zones.html)
- [www.field-studies-council.org/documents/centres/brockhole/climatechangeresources/ks2/Chapter%201.pdf](http://www.field-studies-council.org/documents/centres/brockhole/climatechangeresources/ks2/Chapter%201.pdf)

**Search terms:** climate change, climate zones, seasons

## Cross curricular links

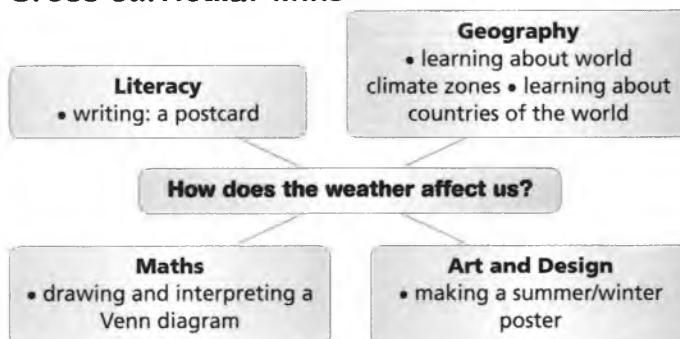

# How does the weather affect us?

## 1 Colour the countries. Show the world climate zones

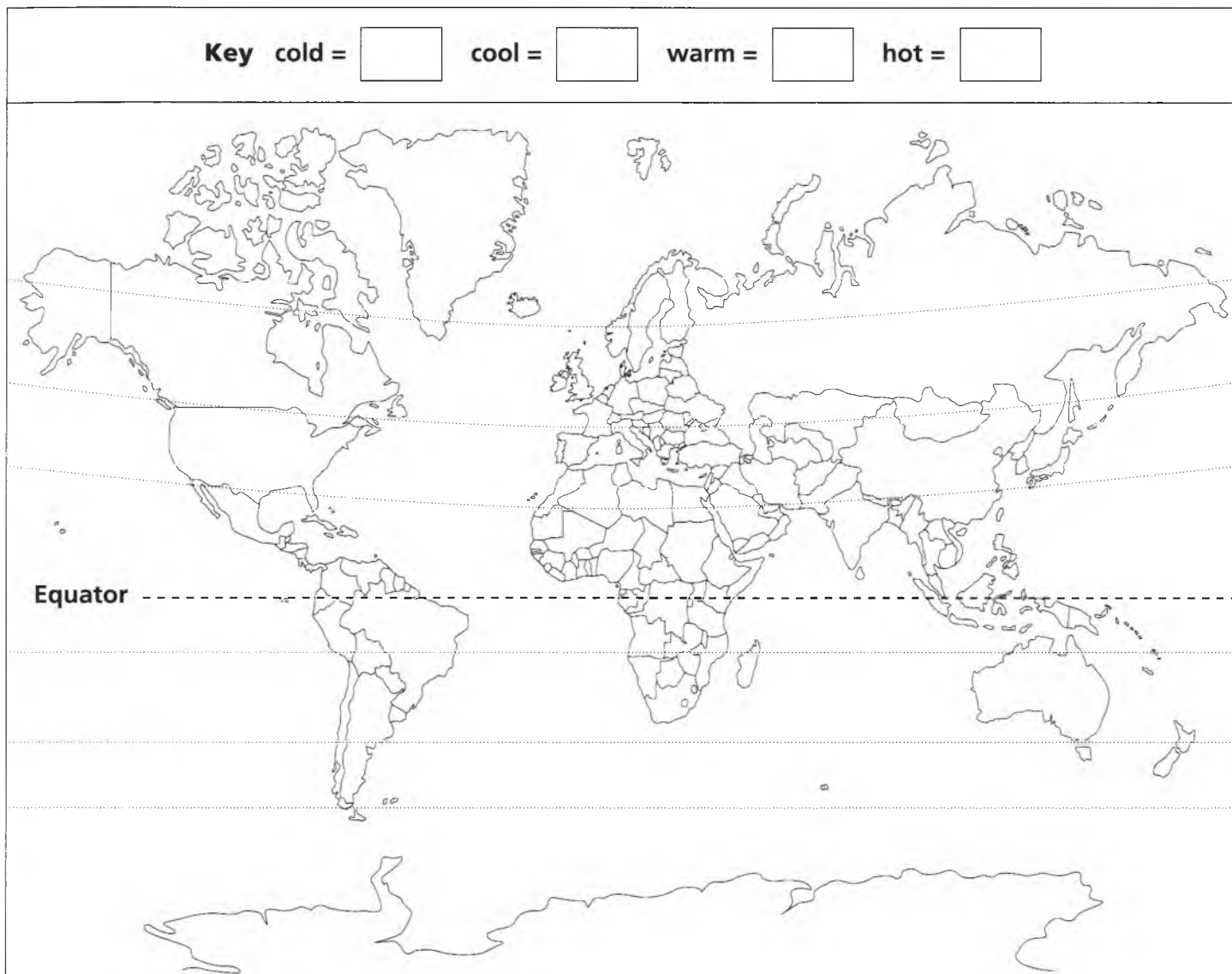

## 2 Things we do in ...

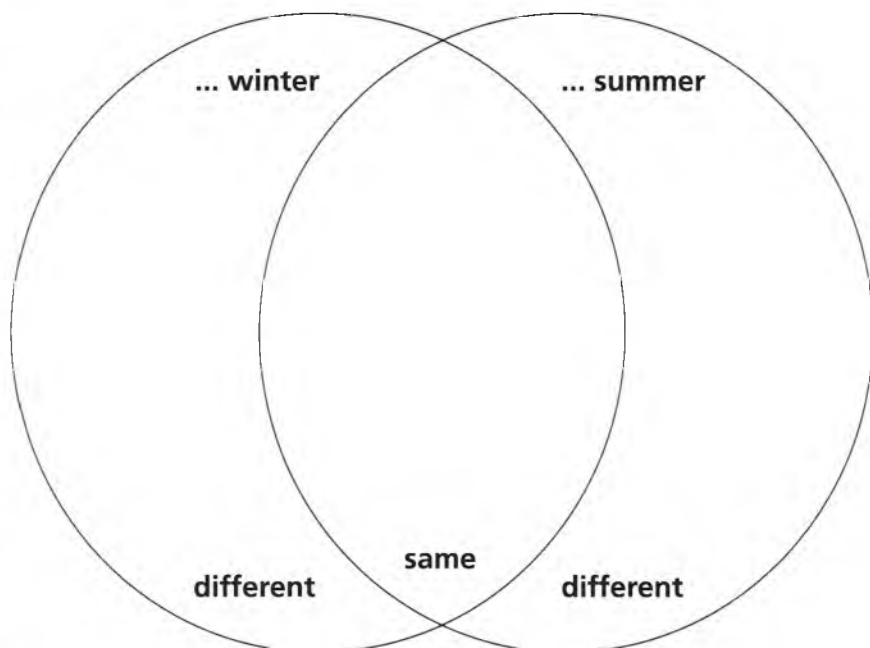

## 3 Find out about another place. Write a postcard

- 1 What is its name?
- 2 Which country is it in?
- 3 Which climate zone is it in?
- 4 What is the temperature?
- 5 How much rainfall does it have?

Lesson  
3a

## The importance of water

## Fact box

- Water is very important. All living things need water. Plants need water to grow. Animals need water to drink. We need water to drink, to have a bath/shower, wash our hair, clothes, dishes and cars, clean our teeth, flush the toilet, cook, water the garden, swim in and for many other things.
- Water expands and floats when it freezes.

## Aims

- To appreciate the importance of water in our daily lives.
- To recognise properties of water as a valuable element.

## Language

- Look at Lesson 5.1b and revise language from Lessons 10.1a & 10.1b
- Vocabulary: *expand, float, freeze, melt, sink, thaw*

## Extra materials

- 1 copy of the Activity page per pupil, Audio Track 69, Audio text, IWB
- prepare 1 day in advance: transparent plastic jug + ½ litre frozen water, coloured pencils, scissors, string

## Warm up

- 1 Talk about why water is important – elicit/share the information in the Fact box, bullet 1, with the class.
- 2 Display the Audio text. Play Audio Track 69. Tell pupils to listen and follow the words. Read the words with the class. Play the Audio again and ask the pupils to clap as they say the words.
- 3 Display the IWB for the pupils to complete the activity.

## Procedure

- 1 Ask the class what happens to water in winter when the temperature is below 0°C (it freezes).
- 2 Give out the Activity sheets and read activity 1. Show the jug of ½ litre of water, frozen. Ask some pupils to feel the ice. Ask *How is it different from water? How did it change when it turned to ice?* (It got bigger.)
- 3 Discuss where to put the jug to change the ice back to water. Put the jug in a warm place in the sun or next to a radiator. Ask *How long do you think it will take for the ice to melt?* Note the estimates.
- 4 Tell the pupils to use 2 different colours to show the water and the ice they can see in the jug after 1, 2 and 3 hours. Ask *Where is the ice?* (Floating at the top.) *What would happen if ice sank?* (The water above it would freeze. In the end, there would be no water to use so nothing could live.)
- 5 When all the ice has melted, tell them to draw a line and colour to show the amount, then write the number of hours. Ask *How long did it take for the ice to melt? Was your estimate right? How much water is left? How much water has evaporated?* Finally, tell them to complete the sentences on the sheet.

## Follow up

- 1 Revise the warm up discussion. Ask *What do we need water for? Then How do we get water? Where does it come from?* Discuss how fortunate we are to be able to turn on the tap and have plenty of water.

- 2 Put pupils into groups of 4. Look at activity 2. Tell them to brainstorm 10 things we do with water and write them on both sides of the 1st cloud. Ask the groups to read their lists.
- 3 Tell the groups to brainstorm 10 important water words and write them on both sides of the 2nd cloud. Ask them about previous lessons, e.g. *What words do you remember from the water cycle?* (e.g. *evaporate, condense, vapour, cloud, puddle, river, lake, sea, rain, storm, hurricane, flood, drought, tap, etc.*)
- 4 Choose a group to read out their list. Ask if other groups had different words.
- 5 Give out the scissors. Ask the pupils to cut out their clouds, attach string and tie the bottom of one cloud to the top of the other. Hang the clouds in the classroom to make a class display.

## Useful websites

- [www.bbc.co.uk/schools/ks2bitesize/science/materials/changing\\_state/play.shtml](http://www.bbc.co.uk/schools/ks2bitesize/science/materials/changing_state/play.shtml)
- [www.kidsgeo.com/geography-for-kids/0132-water-is-important-to-lifer.php](http://www.kidsgeo.com/geography-for-kids/0132-water-is-important-to-lifer.php)

**Search terms:** water + changing states, why water is important

## Cross curricular links

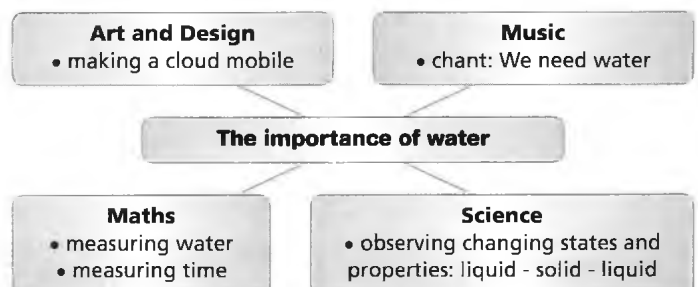

# The importance of water

## 1 Changing ice to water

Look, draw and colour the ice and water in the jug.

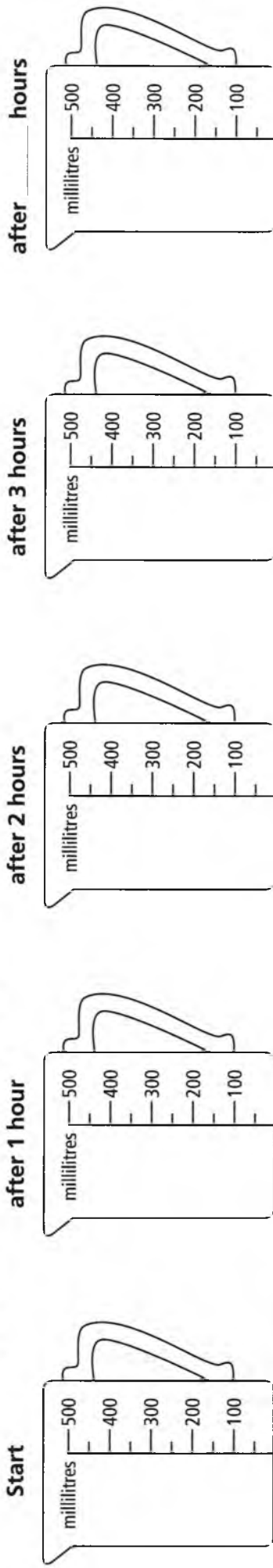

Complete the sentences.

- 1 After 1 hour there are \_\_\_\_\_ ml of water and \_\_\_\_\_ ml of ice.
- 2 After 2 hours \_\_\_\_\_.
- 3 After \_\_\_\_\_ hours the ice has \_\_\_\_\_.
- 4 It took \_\_\_\_\_ for the ice to melt.
- 5 There are \_\_\_\_\_ ml of water left. \_\_\_\_\_ ml of water has evaporated.

## 2 Make a cloud mobile

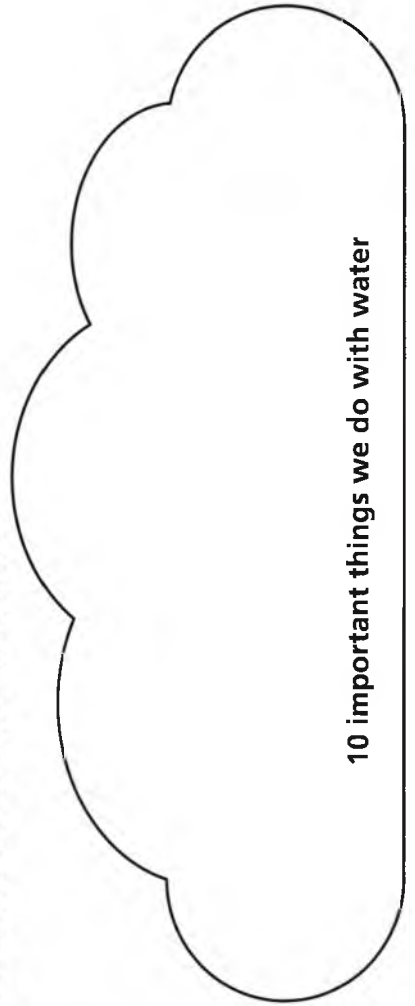

10 important things we do with water

10 important water words

Lesson  
3b

## How do boats float?

## Fact box

- Things *float* because they are *light* for their *size*.
- If they are *heavy* for their size they will *sink*.
- *Materials* that float include *paper, tin foil, plastic, dry wood, polystyrene, feathers, leaves*
- If there is enough air trapped inside any material it will not sink.
- *Materials* that sink include *stone, marble, heavy metals, etc.*

## Aim

- To understand sinking and floating.

## Language

- Vocabulary: *cardboard, float, heavy, light, materials, paper, plastic, polystyrene, sink, size, wood*

## Extra materials

- 1 copy of the Activity page & a piece of A4 paper per pupil, IWB
- objects to test: yoghurt pot, pen, leaf, twig, feather, metal teaspoon, plastic teaspoon, ball of paper, apple, rubber, ping pong ball, polystyrene, candle; paper boat; boat cargoes for each group: paper clips, marbles, small stones, keys, coins; 5 large bowls, each with the same amount of water; exercise books, paper

Cargo	Predictions					Number
	1	2	3	4	5	
paper clips						
marbles						
small stones						
keys						
coin						

## Warm up

- 1 Draw a 3-column table on the board with headings *Object, Prediction* and ✓ or ✗.
- 2 Show each object to test in turn and ask *What is it?* (Write the names in column 1.) *Will it float or sink?* (Write *float* or *sink* in column 2.) Ask pupils to give a reason for each prediction – encourage them to think about how heavy each item is for its size and if there is any air trapped inside it.
- 3 Place each object in turn in the bowl of water to see if it sinks or floats. On the board, in column 3, tick the correct predictions and cross the wrong predictions.

## Procedure

- 1 Give out the paper and Activity sheets. Tell the pupils they are going to make a paper boat. Read through the instructions with the class, then demonstrate how to make a paper boat, step by step, for the pupils to copy. Encourage the more able pupils to help any who have difficulty.
- 2 Divide the class into groups of 5 pupils. Give each group 5 different cargoes. Remind them that the boats will float alone but explain that, if too much cargo is added, they will become too heavy for their size and will sink. Tell them to count how many pieces of each cargo the boats can carry before they sink.
- 3 Draw a table on the board, like the one above right, for the pupils to copy into their exercise books.
- 4 Before they begin, number the pupils in each group 1 to 5. Ask each pupil to predict the number of each cargo and record the predictions on the table. Tell them to think about how heavy each item is for its size.
- 5 Tell the pupils to take turns to put their boat in the water and add a cargo, one piece at a time until the boat sinks. Tell them to count the pieces and record the number before the boat sinks.

- 6 Ask the groups to report back to the class. Find out if their results are the same for each cargo and, if not, discuss why not. Ask if any pupils made a correct prediction.
- 7 Display the IWB for the pupils to complete the activity.

## Follow up

- 1 Make boats from different materials, e.g. tin foil to the same pattern as the paper boat; plastic from a yoghurt pot, plastic straw and sail; and wood from a piece of wood with an ice lolly stick mast. Ask *Which boat do you think will float/sink? Why?* Test the pupils' predictions.
- 2 Repeat the cargo experiment for each boat and compare the results with those for the paper boats.

## Useful websites

- [www.origami-instructions.com/origami-boat.html](http://www.origami-instructions.com/origami-boat.html)
- [www.sciencenetlinks.com](http://www.sciencenetlinks.com)  
Click *Lessons*, scroll down and click *Sink or Float?*

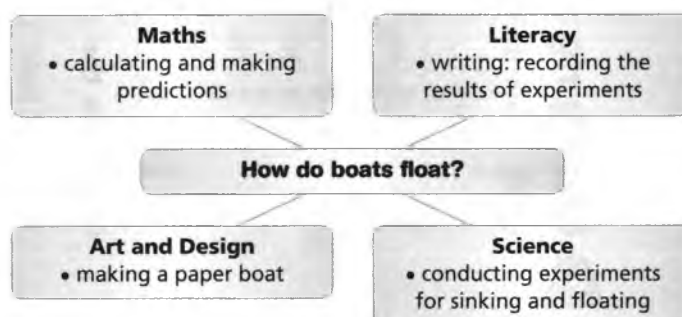

**Search term:** floating and sinking

## Cross curricular links

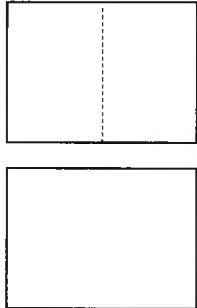

# How do boats float?

## Make a paper boat

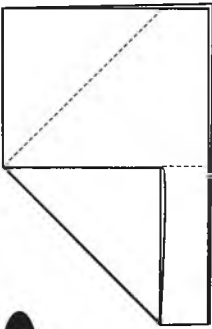
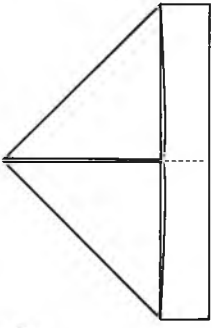
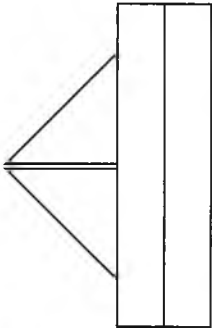
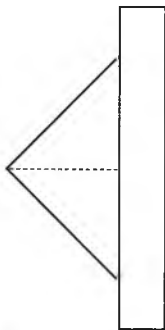
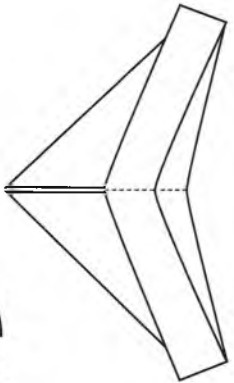
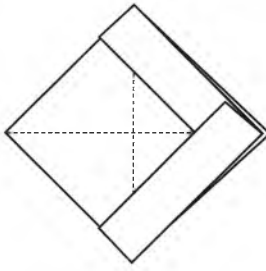
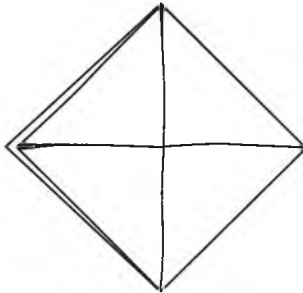
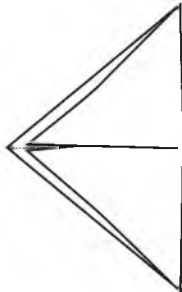
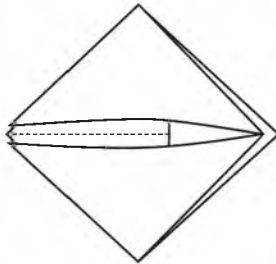
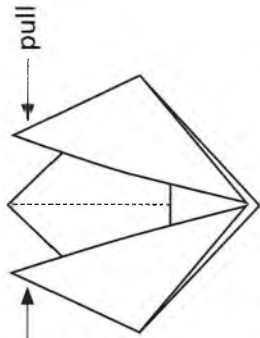
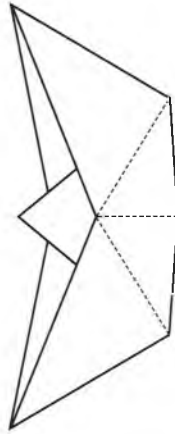
<p><b>1</b></p>  <p>Fold the paper in half from top to bottom</p>	<p><b>2</b></p>  <p>Fold the paper in half again from side to side and then open the paper out again</p>	<p><b>3</b></p>  <p>Fold the left top corner into the centre crease</p>	<p><b>4</b></p>  <p>Fold the right top corner into the centre crease to make a triangle</p>	<p><b>5</b></p>  <p>Open the bottom and fold the bottom edge up</p>
<p><b>6</b></p>  <p>Turn the paper over and fold the other edge up</p>	<p><b>7 and 8</b></p>  <p>Fold the left hand corners over. Fold the right hand corners over</p>		<p><b>9</b></p>  <p>Open the bottom in the middle and pull the triangle to make a diamond shape</p>	<p><b>10</b></p>  <p>Fold the bottom triangle up</p>
<p><b>11</b></p>  <p>Turn the paper over and fold the other bottom triangle up</p>	<p><b>12</b></p>  <p>Open the bottom of the triangle in the middle and pull the triangle to make a small diamond shape again.</p>	<p><b>13</b></p>  <p>pull → pull</p> <p>Pull the top points away and flatten the paper to make the boat shape</p>	<p><b>14</b></p>  <p>Open the bottom of the boat and push your fingers inside the point to open the base.</p>	

# Answers

## Unit 1

### The Human Body

#### Lesson 1a

#### Where are your organs? page 13

##### 1 Cut and stick

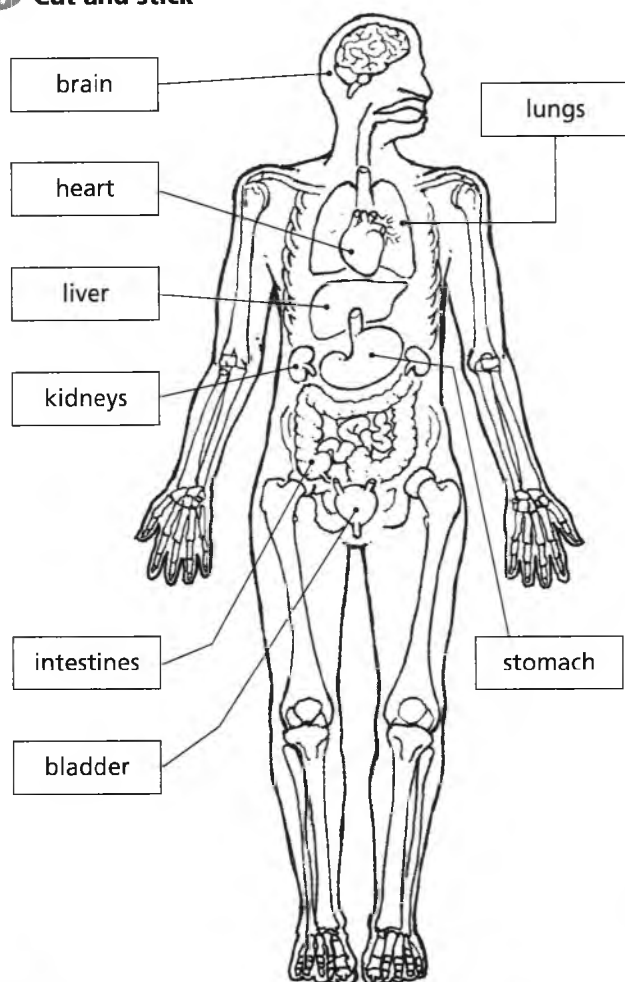

##### 2 Complete the crossword

Across: 3 brain, 7 intestines, 8 heart

Down: 1 bladder, 2 lungs, 4 kidneys, 5 stomach, 6 liver

#### Lesson 1b

#### What do your organs do? page 15

##### 1 Write the names of the organs

From left to right:

kidneys – They process water.

stomach – It processes and stores food.

lungs – They breathe in oxygen.

liver – It processes chemicals.

brain – It sends messages to the muscles.

heart – It pumps the blood.

intestines – they process the food.

#### Lesson 2a

#### What can I do with my body? page 17

##### 1 Write the body parts

Answers provided in the Fact box on the teacher's page.

##### 2 Make me move

labels: biceps in the top box; triceps in the bottom box

#### Lesson 3a

#### How do you breathe? page 21

##### 1 Are these sentences true or false?

1 T, 2 F, 3 T, 4 T, 5 T, 6 T, 7 F

2 Your blood carries oxygen to all parts of your body.

7 Children have a faster pulse rate than adults.

#### Lesson 3b

#### Measure your pulse page 23

##### 2 Joe's heart beat

Running will make Joe's heart beat the fastest.

running: 132, walking: 98, sitting: 78, sleeping: 67

##### 3 Find these words

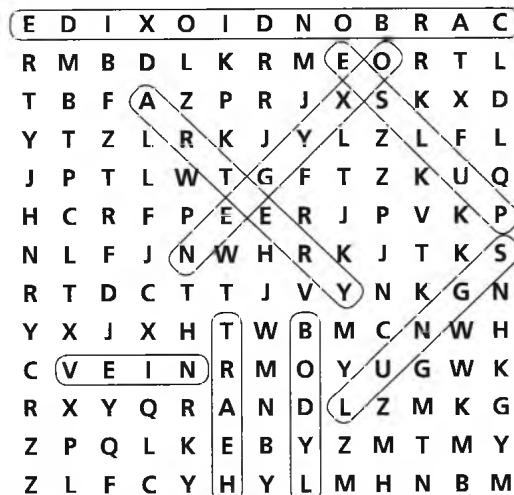

## Unit 2

### Food and Health

#### Lesson 1b

#### What did Little Red Hen eat? page 27

##### 1 Number the pictures

3, 2, 5, 1, 4

##### 2 Find 6 differences

In picture B there is: a mouse eating wheat from a sack,

a bird singing in the rafters, an apron on the Little Red

Hen, a dog eating a bone, a cat chasing a mouse, a rat

running up the wall

#### Lesson 2a

#### What do you like to eat for lunch? page 29

##### 1 Choosing a healthy lunch

pupils tick: 1 chicken and rice, 2 baked potato and

cheese, 3 meat and salad, 4 fish, potatoes and peas,

5 pasta and tomato sauce, 6 a banana and an apple

#### Lesson 2b

#### What's in Tim's sandwich? page 31

##### 1 Tim's sandwich

Missing words: Jane, pain, said, bread, cheese, squeeze,

treat, eat

**Lesson 3a**

**Illnesses and medicine** page 33

**2 Complete the crossword**

Across: 3 sore throat, 4 cold, 5 headache, 6 high temperature

Down: 1 influenza, 2 stomach ache, 4 cough

**Lesson 3b**

**A visit to the hospital** page 35

**2 Fill in the gaps**

1 hurt, leg; 2 phoned; 3 straight, hospital; 4 x-ray;

5 stay, two weeks

**Unit 3 Living Things**

**Lesson 1a**

**Animals, plants and their habitats. Where do they live?** page 37

**Animals and their habitats**

Pupils stick their coloured, cut-out animals on the pictures:

farm: cow, sheep, horse, pig, hen

farm and woodland: birds, owl, fox, mouse, ant, spider

pond: duck, frog

sea: shark, fish

sea and icy land: polar bear

rainforest: snake, parrot, monkey

desert: snake, camel

**Lesson 1b**

**What can you find around here?** page 39

**2 Venn diagram**

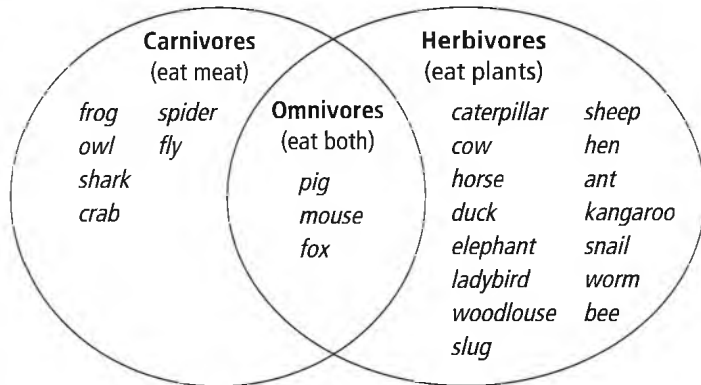

**Lesson 3a**

**Animals in danger** page 45

**2 Find the animals in danger**

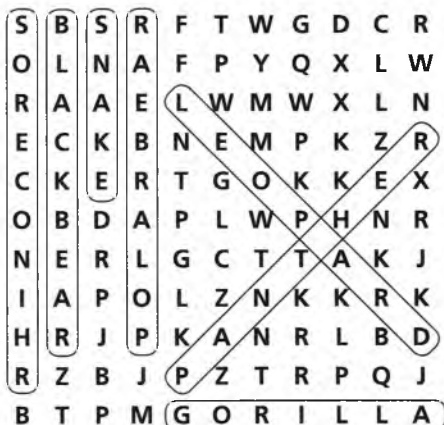

**Lesson 3b**

**Prehistoric animals: dinosaurs** page 47

**2 Help the dinosaurs find their names in the maze**

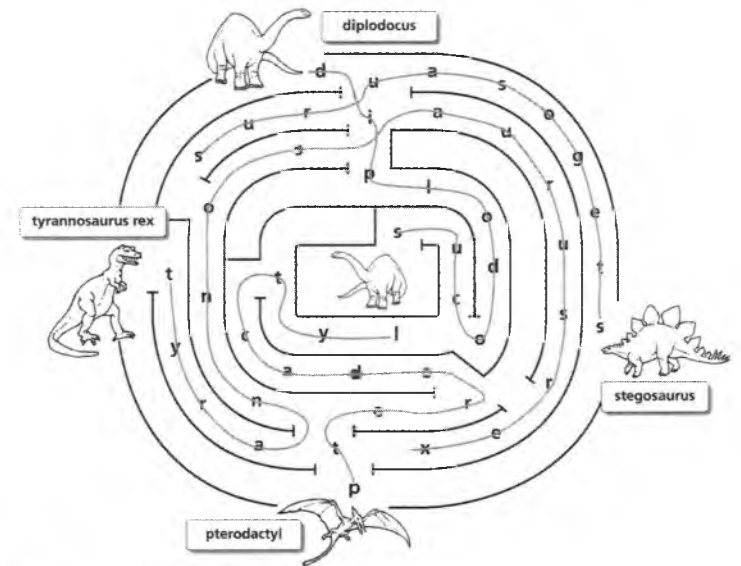

The diplodocus arrived first.

**Unit 4 Life Cycles**

**Lesson 1a**

**The life cycle of a bean plant** page 49

**1 Cut, order and label**

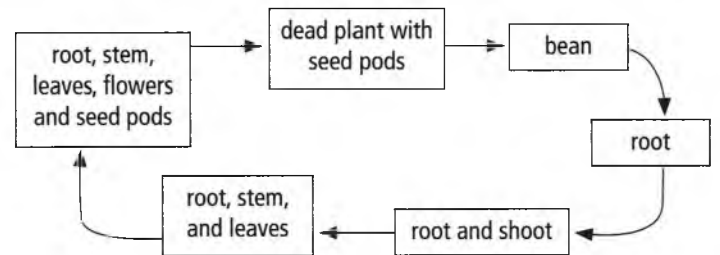

**2 Ask and answer**

- 1 The root grows first. 2 The shoot grows next.
- 3 The seed pods grow last. 4 Pupils' own answers, e.g. The dead plant looks brown and dried/shrivelled up.

**Lesson 1b**

**The life cycles of plants** page 51

**1 Draw and label**

4 plant with seed pods	1 bean seed	4 tree with apples	1 apple seed
bean plant		apple tree	
3 plant with stalk, leaves and flowers	2 seedling with root and shoot	3 tree with trunk, leaves and flowers	2 seedling with root and shoot
4 plant with seed heads	1 sunflower seed	4 tree with open pine cones	1 pine seed
sunflower plant		pine tree	
3 plant with stalk, leaves and flowers	2 seedling with root and shoot	3 tree with trunk, leaves and new pine cones	2 seedling with root and shoot

**Lesson 2a**

**The life cycle of a frog**

page 53

**1 What happens first?**

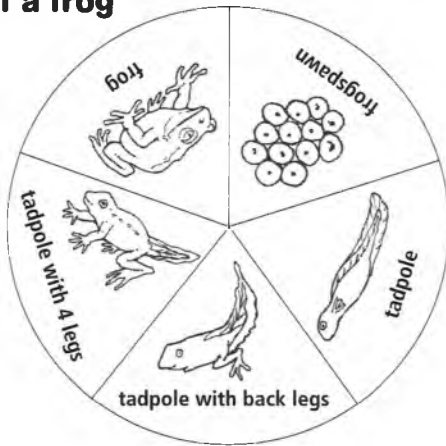

**Lesson 2b**

**The life cycle of butterflies and moths**

page 55

**1 There are four stages in the life cycle of a butterfly and a moth**

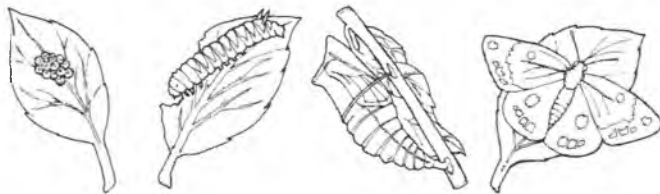

<b>Stage 1:</b> A butterfly or moth lays some eggs on a leaf.	<b>Stage 2:</b> A caterpillar hatches from an egg. It eats and grows.	<b>Stage 3:</b> The caterpillar spins a cocoon of silk and changes into a chrysalis.	<b>Stage 4:</b> A butterfly or moth comes out of the chrysalis.
--	--	---	--

**Lesson 3a**

**Life cycles in changing habitats** page 57

	Polar bears	Arctic Terns	Bison
Where do they live?	in the Arctic	the Arctic and Antarctic	North America
What do they eat?	fish and seals	sand eels, small fish, insects	grass
When are they born?	in winter	May and June	in spring at the end of migration
Where are they born?	in a den in the snow	in nests on the ground in the Arctic	in a meadow
What are the young called?	cubs	chicks	calves
How long do they live?	for about 25 years	up to 34 years	for 20 to 25 years
Do they hibernate?	yes, the females do	no	no
Do they migrate?	no	yes	yes
One more fact	the cubs leave the den in the spring	they fly more than 35,000 kilometres every year	Wild bison nearly became extinct and are now protected

**Lesson 3b**

**What happens when an environment is changed?**

page 59

**Read the newspaper**

**Write some of the persuasive words and phrases from the letter here:**

We think it is a bad thing that ...; We think it should be stopped; We would like ...; If we must ..., why ...; It is too late ...; Many small birds only live two years so ...; We shall miss ...; ... please, please, please help us to find a way to ...

**Reread the newspaper article and the letter and write 2 facts and 2 opinions here:**

For example:

**Fact:** Next week the Old Park will be turned into a car park.

**Fact:** Many birds have nests in those trees.

**Opinion:** We think it is a bad thing that the Old Park is going to be made into a car park.

**Opinion:** We think it should be stopped.

**Unit 5**

**Materials and Properties: Changing Materials**

**Lesson 1a**

**Can I change these shapes?** page 61

**Materials game**

Material	squeeze	bend	twist	pull
wood	no	no	no	no
foil	yes	yes	yes	yes
clay	yes	yes	yes	yes
stone	no	no	no	no
plastic bag	yes	yes	yes	yes
plastic bottle	yes	yes	yes	no
wool	yes	yes	yes	yes
paper	yes	yes	yes	no
metal coin	no	no	no	no
metal paper clip	yes	yes	yes	yes

**Lesson 1b**

**Fair tests for change** page 63

**2 Draw 6 pairs of pictures to show the changes.**

Afterwards:

metal: hot; looks the same

chocolate: melts

bread: turns brown and hard

water: begins to bubble and steam

paper: buckles, turns brown

stone: hot; looks the same

**Lesson 2a**

**Will it dissolve in water?** page 65

**2 Which substances will dissolve in water?**

1 insoluble, 2 soluble, 3 soluble, 4 insoluble

**3 What will dissolve in water?**

1 sand, 2 salt, 3 wood, 4 sugar, 5 wool, 6 glass, 7 iron

### Lesson 3a

## Separating mixtures by sieving and filtering page 69

Use the words in the box to label the diagrams

- 1 chips, cooking oil, chip basket
- 2 fish, fishing net, sea water
- 3 salad colander, water
- 4 tea leaves, tea bag, tea
- 5 sieve, stones, sand
- 6 filter paper, salt water solution
- 7 net, footballs, tennis balls

### Unit 6

### Physical Processes

#### Lesson 1a

### Earth, sun and moon page 73

#### 1 Write the names, listen and colour

from left to right: sun (orange and red with black spots), Earth (blue and green), moon (white and blue with black marks)

#### 2 Listen, match, write the words (you don't need one of them)

The sun is a star. It is the biggest and the hottest.  
 The Earth is a planet. It moves around the sun in one year.  
 The moon is a satellite. It moves around the Earth.  
sun is the word that it not needed.

#### Lesson 2b

### What do we wear in winter page 79

#### 2 Which climate? Where do we wear these clothes?

Hot climate: sun hat, T-shirt, swimming costume, trousers, dress, shorts, sandals, shoes

Cold climate: coat, boots, jumper, hat, trousers, dress, scarf, gloves, socks, shoes

#### Lesson 3a

### The solar system page 81

#### 2 Draw the planets in order. Write the names.

Pupils draw and label, from left to right: Mercury, Venus, Earth, Mars, Jupiter, Saturn, Uranus, Neptune, Pluto

### Unit 7

### Forces and Motion

#### Lesson 1a

### Moving toys: pushes and pulls page 85

#### Push or pull?

1 pull, 2 push, 3 push, 4 pull, 5 pull, 6 push, 7 push, 8 push

#### Lesson 1b

### Pushing, pulling and slopes page 87

#### Listen, look and number

A10: flat, easy; B8: slope, hard; C6: steep slope, harder;  
 D4: steep slope, harder; E2: flat, easy; F9: flat, easy;  
 G7: slope, hard; H5: flat, easy; I3: slope, easier; J1: flat, easy

#### Lesson 2a

### Friction and movement page 89

#### Friction slows things down

Tom slides faster at first because Anna's big boots slow her down more than Tom's shoes slow him down.

She takes off her boots.

The skier in picture 5 is faster.

There is more friction in picture 6.

#### Lesson 3a

### Magnetic force page 93

#### 1 Colour and cut out. Match and stick

Magnets and magnetism				
Opposite poles attract	S	N	S	N
Like poles repel	S	N	N	S
Like poles repel	N	S	S	N

#### 2 Find out, then answer the questions

- 1 They repel each other
- 2 Yes

3 S N S N S N  
 or  
 N S N S N S

### Unit 8

### Light and Sound

#### Lesson 1a

### Light sources page 97

#### Which things are giving out light?

- 1 (lighted candle) – yes – A lighted candle gives out light.
- 2 (torch, on) – yes – A torch, switched on, gives out light.
- 3 (moon) – no – The moon reflects sunlight.
- 4 (stars) – yes – Stars give out light.
- 5 (a cat's eyes) – no – A cat's eyes reflect light.
- 6 (unlit match) – no – An unlit match doesn't give out light.
- 7 (unlit light bulb) – no – An unlit light bulb doesn't give out light.
- 8 (wood fire) – yes – A lighted wood fire gives out light.
- 9 (sun) – yes – The sun gives out sunlight.
- 10 (mirror) – no – A mirror reflects light.
- 11 (unlit lamp) – no – An unlit lamp doesn't give out light.
- 12 (TV) – yes – A television, switched on, gives out light.
- 13 (unlit candle) – no – An unlit candle doesn't give out light.
- 14 (lighted match) – yes – A lighted match gives out light.
- 15 (lighted lamp) – yes – A lighted lamp gives out light.

#### Lesson 2a

### Reflections page 101

#### 1 What will I see in the mirror?

#### 2 What I saw in the mirror

- 1 reversed image, 2 true image, 3 image upside down, 4 wide image, 5 blurred/no image

## Lesson 2b

### Everyday sounds and volume page 103

#### 2 Noisy day rap

pupils match words and pictures: snap – snapping fingers, hiss – hissing snake, bang – hand banging drum, rattle – baby’s rattle, squeak – squeaking mouse, footsteps – footsteps, whisper – child whispering, shout – child shouting, crackle – hand in crisp packet, pop – popping balloon, whistle – mouth blowing whistle

## Lesson 3b

### Sound: pitch page 107

#### 3 Answer these questions

- 1 Long strings make the lowest notes.
- 2 violin
- 3 tuba
- 4 kettle drum

## Unit 9

### Environmental and Global Issues: Conserving Resources

## Lesson 1a

### Save – don’t waste! page 109

#### Saving water, electricity and fuel

- 1 Save water! Turn off the tap! Never leave it dripping!
- 2 Save electricity! Turn off the computer when you have finished!
- 3 Save fuel! Go by bus or give your friend a lift!
- 4 Save fuel! Ride a bicycle!
- 5 Save water! turn off the tap while you clean your teeth!
- 6 Save electricity! Turn off the lights and heater when you go out!

## Unit 9

### Environmental and Global Issues: Communication

## Lesson 2a

### Personal communication links page 113

#### 1 Can you read this text?

See you for tea at 3 today.

#### 2 Thinking of you

A – parcel post – 4, B – computer + webcam – 5,  
C – text – 3, D – letter post – 1, E – Internet – 6,  
F – email – 2, G – mobile phone – 7, H – telephone – 8

## Unit 9

### Environmental and Global Issues: Members of a Global Community

## Lesson 2b

### Global communications page 113

#### 1 Here is the news

television	Internet	mobile phone	newspaper	radio
A	B	C	D	E
3	5	1	2	4

## Unit 10

### Weather and Water

## Lesson 1a

### The water cycle, page 121

#### 1 Label the water cycle

- Pupils label boxes, from top to bottom:
- 2 water vapour condenses in to clouds
  - 3 water falls as rain
  - 1 water evaporates into the air
  - 4 water returns to the sea

## Lesson 1b

### Where does the water go? Rain and puddles, page 123

#### 3 Spot the difference. Which family is saving water?

The family in B is saving water.

Family A is wasting water from the hose pipe (playing, watering plants, washing the car) and the tap (brushing teeth).

## Lesson 2b

### How does the weather affect us? page 127

#### 1 Colour the countries. Show the world climate zones

Pupils colour the climate zones, from top to bottom:  
blue – cold countries, green – cool countries, orange – warm countries, red – hot countries, orange – warm countries, green – cool countries, blue – cold countries

## Lesson 3a

### The importance of water, page 129

#### 2 Make a cloud mobile

10 important things we do with water, e.g. drinking, watering plants, bathing, showering, washing hair, washing clothes, washing dishes, washing cars, cleaning teeth, flushing toilet, cooking, swimming

10 important cloud words, e.g. evaporate, condense, vapour, puddle, river, lake, sea, rain, storm, hurricane, flood, drought, tap

# Tapescript

## Unit 1

### Lesson 1a

#### Where are your organs?

##### T2

###### Song 1: Head, shoulders, knees and toes

Head, shoulders, knees and toes, knees and toes.  
Head, shoulders, knees and toes, knees and toes.  
Eyes and ears, and mouth and chin.  
Head, shoulders, knees and toes, knees and toes.

Head, shoulders, knees and toes, knees and toes.  
Head, shoulders, knees and toes, knees and toes.  
Eyes and ears and mouth and chin.  
Head, shoulders, knees and toes, knees and toes.

##### T3

###### Song 2: Brain, heart, lungs and liver

Brain, heart, lungs and liver, lungs and liver.  
Brain, heart, lungs and liver, lungs and liver.  
Stomach, kidneys, intestines.  
Brain, heart, lungs and liver, lungs and liver.

Brain, heart, lungs and liver, lungs and liver.  
Brain, heart, lungs and liver, lungs and liver.  
Stomach, kidneys, intestines.  
Brain, heart, lungs and liver, lungs and liver.

## Unit 1

### Lesson 1b

#### What do your organs do?

##### T4

- |                               |   |
|-------------------------------|---|
| 1 What does your heart do?    | a It pumps the blood.                       |
| 2 What does your brain do?    | b It sends messages to the muscles.         |
| 3 What does your liver do?    | c It processes chemicals.                   |
| 4 What does your stomach do?  | d It processes and stores food.             |
| 5 What do your kidneys do?    | e They process water.                       |
| 6 What does your bladder do?  | f It stores water until I go to the toilet. |
| 7 What do your lungs do?      | g They breathe oxygen.                      |
| 8 What do your intestines do? | h They process the food.                    |

## Unit 1

### Lesson 2b

#### What do you look like?

##### T5

###### My friends, Joe and Jim

Hello. Our names are Joe and Jim  
We are twins.  
We are going to school.  
I'm Joe. I'm tall.  
I've got brown hair and blue eyes.  
I've got a green cap.  
I've got a red sweater and black trousers.  
I've got brown shoes and a purple bag.  
My brother, Jim, is different.  
Colour him in with some different colours.

## Unit 2

### Lesson 1b

#### What did Little Red Hen eat?

##### T6

###### Story: Little Red Hen

*Hen:* Can you help me plant the wheat seeds?  
*Rat/Dog/Cat:* No, we're too tired.  
*Hen:* Then I will plant them myself.

*Hen:* Can you help me cut the wheat?  
*Rat/Dog/Cat:* No, we're too sleepy.  
*Hen:* Then I will cut it myself.

*Hen:* Can you help me make the flour?  
*Rat/Dog/Cat:* No, we're too busy.  
*Hen:* Then I will make it myself.

*Hen:* Can you help me make the bread?  
*Rat/Dog/Cat:* No, we're too hungry.  
*Hen:* Then I will make it myself.

*Hen:* Will you help me eat the bread?  
*Rat/Dog/Cat:* Yes!  
*Hen:* Oh, no, I will eat it all myself!

**What do you like to eat for lunch?****T7****Chant: Food, lovely food**

Food lovely food, cold ham and pasta.  
When we're ready for lunch,  
We ask the question,  
'What do you like to eat, to help your digestion?'

Food lovely food, you must try it.  
Eat all your vegetables and carbohydrates.  
Just try a bit of fruit and some rice.  
Mix in your favourite meat to make it nice.  
It will help you grow and be strong.  
Keep eating a healthy diet and live long!

Food lovely food, cold ham and pasta.  
When we're ready for lunch,  
We ask the question,  
'What do you like to eat, to help your digestion?'

**What's in Tim's sandwich?****T8****Poem: Tim's sandwich**

Tim had a naughty sister, Jane.  
One day she said 'I've got a pain.'  
'Maybe you're hungry, Jane,' Tim said,  
'I'll make you a sandwich with some bread.'

First, he put in a piece of cheese  
And then he gave it a squeeze.  
'I think I'll make this a special treat –  
This is a sandwich she'll love to eat!'

Next, he took a nice long worm –  
He knew that this would make her squirm.  
Then he put in a big grey slug  
And next he found a great fat bug!

He thought the sandwich needed a filler  
So then he found a green caterpillar.  
Next he took a huge black fly  
And put that in too – I don't know why!

At last the sandwich was ready to eat.  
Tim smiled a big smile; his work was complete.  
'Dear Jane,' he said, 'do take a bite.'  
But she took one look and had such a fright!

She ran away fast as she shrieked to Tim,  
'You eat your sandwich, I'm full to the brim.  
I'm not a bit hungry, I've had enough.  
You eat it all. I hate that stuff!'

**Illnesses and medicine****T9****Story: Tim's day in bed**

*Mum:* You can stay in bed today.

*Mum:* Please can you come and see my son? He's very ill today.

*Doctor:* I can come at ten o'clock.

*Doctor:* What's the matter?

*Tim:* I feel very hot and I've got a sore throat and a headache.

*Doctor:* You've got influenza but when you're feeling better, you can get up and eat some of your favourite ice cream.

**A visit to the hospital****T10****Chant: Two little boys were jumping on the bed**

Two little boys were jumping on the bed,  
One fell off and bumped his head.  
Mama called the doctor and the doctor said,  
'Put that boy straight to bed!'

One little boy was jumping on the bed,  
He fell off and broke his leg.  
Mama called the doctor and the doctor said,  
'Put that boy straight to bed!'

In came the doctor and shook his head.  
'Your leg is broken. Oh, dear!' he said.  
'You must go to hospital and get an x-ray.'  
Then out went the doctor, off on his way.

**T11****Story: The accident**

*Boy 1:* What's the matter?

*Boy 2:* Oh dear, I've hurt my leg!

*Boy 1:* You must go to the doctor's.

*Boy 2:* Hello, Dad. My leg hurts badly. I must see a doctor at the hospital.

*Dad:* OK. I can take you now.

*Receptionist:* What's your name? How old are you?

*Boy 2:* My name's John. I'm eleven years old.

*Receptionist:* Come this way, please.

*Doctor:* Hello. What's the matter?

*Boy 2:* I have hurt my leg playing football.

*Doctor:* You must have an x-ray.

*Doctor:* Yes, it's broken here.

*Mother:* Now you must stay at home for two weeks!

*Boy 2:* Hurray, that's good!

**Animals, plants and their habitats****Where do they live?****T12****Song: The animals went in two by two**

The animals went in two by two, hurrah, hurrah!  
 The animals went in two by two, hurrah, hurrah!  
 The animals went in two by two, the elephant and  
 the kangaroo  
 And they all went into the ark, for to get out of the rain.

The animals went in three by three, hurrah, hurrah!  
 The animals went in three by three, hurrah, hurrah!  
 The animals went in three by three, the wasp, the ant  
 and the bumble bee  
 And they all went into the ark, for to get out of the rain.

The animals went in four by four, hurrah, hurrah!  
 The animals went in four by four, hurrah, hurrah!  
 The animals went in four by four, the great big cow  
 was stuck in the door  
 And they all went into the ark, for to get out of the rain.

**Prehistoric animals: dinosaurs****T13**

This is a tyrannosaurus rex.  
 First, draw two long, strong legs with large feet  
 at the back of the body.  
 Draw the bones in the legs and feet.  
 Draw three sharp claws on the feet.  
 Now draw two short arms at the front of the body.  
 Draw two sharp claws as hands at the end of the arms.  
 Then draw the skeleton in the arms.  
 Finally, colour your picture.

**The life cycle of a bean plant****T14****Song: The life of a plant goes round and round**

The life of a plant goes round and round,  
 Round and round, round and round.  
 The life of a plant goes round and round,  
 All year long.

The roots of a plant grow down, down, down,  
 Down, down, down, down, down, down.  
 The roots of a plant grow down, down, down,  
 All year long.

The stem of a plant grows up to the sky,  
 Up to the sky, up to the sky.  
 The stem of a plant grows up to the sky,  
 All year long.

The leaves and flowers grow by and by,  
 By and by, by and by.  
 The leaves and flowers grow by and by,  
 All year long.

The flowers make seeds that fall to the ground,  
 Fall to the ground, fall to the ground.  
 The flowers make seeds that fall to the ground  
 And grow next year!

**T15**

This is a bean.  
 The bean has a root.  
 The bean has a root and a shoot.  
 The bean plant has a root, stem and leaves.  
 The bean plant has a root, stem, leaves, flowers  
 and seed pods.

## The life cycle of a frog

### T16

#### Song: Metamorphosis I – Frogs

Oh what, oh what is meta-morph-osis?  
This long, long word means 'many changes'.  
Oh what, oh what is meta-morph-osis?  
Hear what happens to a frog.

Oh Mama Frog, she lays the frogspawn,  
Then the tadpoles all hatch out of it.  
Heads and tails all wiggle round a bit.  
Hear what happens to a frog.

Heads and tails, they grow legs and feet,  
Tiny frogs, they look very sweet.  
Lose their tails, now the frog's complete!  
That's what happens to the frog!

### T17

- First stage: a frog lays hundreds of eggs. The eggs are called frogspawn.
- Second stage: tadpoles hatch out of the eggs; the tadpoles eat and grow bigger.
- Third stage: the back legs start to grow and the tail gets shorter.
- Fourth stage: the front legs grow.
- Fifth stage: the tail has gone and now the tadpole is a small frog.

## The life cycle of butterflies and moths

### T18

#### Song: Metamorphosis II – Butterflies and moths

Oh what, oh what is meta-morph-osis?  
This long, long word means 'many changes'.  
What, oh what is meta-morph-osis?  
Hear what happens to a moth.

Oh Mama Moth she lays a hundred eggs.  
Caterpillars all hatch out of them.  
Heads and tails all wiggle round a bit.  
Hear what happens to a moth.

Caterpillars eat and eat and eat,  
Then wrap up inside a silken sheet.  
Turn to moths while they're asleep.  
Hear what happens to a moth.

Oh what, oh what is meta-morph-osis?  
This long, long word means 'many changes'.  
What, oh what is meta-morph-osis?  
Hear what happens to a moth!

### T19

- There are four stages in the life cycle of a butterfly and a moth.
- Stage 1: A butterfly or moth lays some eggs on a leaf.
- Stage 2: A caterpillar hatches from an egg. It eats and grows.
- Stage 3: The caterpillar spins a cocoon of silk and changes into a chrysalis.
- Stage 4: A butterfly or moth comes out of the chrysalis.

## Life cycles in changing habitats

### T20

#### Arctic terns

Arctic terns are seabirds. In May and June Arctic terns nest on the ground in the Arctic. They feed their chicks on sand eels, small fish and insects. In September, when the young birds have grown and winter is coming, they begin to fly south. When they reach the Antarctic the southern summer has begun. The birds fish in the sea but they do not land on the snow and ice. In March, when it begins to grow colder and darker, they migrate north again. Arctic terns fly more than 35,000 kilometres every year to match their life cycle to the changing seasons.

### T21

#### Bison

Wild bison live in the grasslands of North America. In the spring they migrate hundreds of kilometres northwards to places such as Yosemite, where there has been thick snow all winter. Most calves are born in grassy meadows at the end of the migration. When the calves have grown and there is little grass left, the herds migrate southwards before the snow falls again.

### T22

#### Polar bears

Polar bears live in the Arctic where it is very cold and snowy. Winter lasts for six months and it is dark all the time. The bears have thick fur to keep them warm. Female bears hibernate in winter. They dig dens in the snow where it is warmer. Their cubs are born in the dens and grow up in a safe place, away from male bears which might kill and eat them. They leave the den in the spring when their mothers go out to catch fish and seals.

## What happens when an environment is changed?

### T23

It is very cold.  
There is a lot of snow.  
There is sea all around.  
In winter it is dark all the time.  
What kind of animal could live in this habitat?

### T24

It is warm in summer and cold in winter.  
Sometimes there is rain.  
Grass grows very well.  
What kind of animal could live in this habitat?

### T25

#### The End of the Old Park

This is your last chance to go to the Old Park. Next week the Old Park will be turned into a car park. The beautiful 100-year-old trees will be cut down. The grass and flower beds will be dug up. In two weeks' time there will be space for 50 cars to park but there will be no green space for people, birds and animals to enjoy.

### T26

Dear Readers,

We think it is a bad thing that the Old Park is going to be made into a car park. We think it should be stopped. We would like the park to stay as it is now, because so many birds live there. It is a good habitat for them in the spring.

If we must have a new car park why do the trees have to be cut down so soon? Many birds have nests in those trees. Many eggs have hatched and the baby birds need to eat the caterpillars that are on the flower beds now. It is too late for them to start their life cycle again in another place. Many small birds only live two years so next year there will be no new adults to lay eggs. We shall miss having the birds around.

If the park must be destroyed please, please, please help us to find a way to keep the trees and flowers for a few more weeks until this year's baby birds can leave the nest.

Yours faithfully,  
Tom and Anna

## Can I change these shapes?

### T27

#### Song: Can I change the shape?

Is it hard? Is it soft?  
Will it twist or bend?  
If I pull it hard  
Will it snap at the end?

If I shake it hard  
Will bits fall out?  
Can I change the shape?  
How can I find out?

I can push, I can pull,  
I can twist and shake,  
I can squeeze,  
I can bend.  
Will it snap at the end ?

It is hard not soft.  
It will twist and bend.  
I pulled it hard  
And it snapped at the end!

**Fair tests for change****T28****Chant: A fair test**

'It's not fair!'

'I don't care!'

'Our test is not

Fair, fair, fair!

I had two goes

You had three!

That doesn't seem

Very fair to me!

It's not fair!'

'I don't care!'

'Our test is not

Fair, fair, fair!

Must be fair!

We must care!

Our test must be

Fair, fair, fair!

Every test must

Be the same.

To be a fair test

Not just a game.'

**T29****A fair test to find out how some everyday materials change when heated****Equipment**

oven set at 100°C

6 metal trays

5-minute timer

camera

chocolate

water

bread

paper

stone

**Method**

- 1 Heat the oven to 100 degrees C.
- 2 Put the chocolate, bread, stone, paper and water on the trays.
- 3 Leave one tray empty.
- 4 Take a photograph of each tray.
- 5 Put all the trays in the oven for 5 minutes.
- 6 Take out the trays and photograph each one.

**Will it dissolve in water?****T30**

A. What happens if I put sand into water?

Can you see the sand?

Is it still there?

This is now a mixture of sand and water.

B. What happens if I put salt into water?

Can you see the salt?

Is it still there?

The salt is still there but you cannot see it.

It is a solution of salt and water.

The salt has dissolved in the water.

**T31****Song: DISSOLVE**

DISSOLVE.

Salt dissolves in water

Just you wait and see!

DISSOLVE.

Pour salt into water,

Watch it disappear.

DISSOLVE.

Salt dissolves in water.

Now the water's clear!

**T32**

Some substances dissolve when you mix them with water.

Soluble substances dissolve. You cannot see the substance but it is still there. The new liquid is called a solution.

Substances that do not dissolve are insoluble.

**A fair test: which substance dissolves more quickly?****T33****Planning box**

What do you want to find out?

Write a short title.

What equipment will you need?

Make a list.

Write some instructions.

Put them in order and number them.

Write some instructions.

Put them in order and number them.

Draw a results table.

Note the results.

What have you found out?

Write this in the conclusion.

## Separating mixtures by sieving and filtering

### T34

#### Word box

fishing net  
chips,  
cooking oil  
fish  
footballs  
salad  
sand  
sea water  
stones  
tea  
tea leaves  
tennis balls  
water  
chip basket  
filter paper  
net  
sieve  
colander  
tea bag  
salt water solution

## Earth, sun and moon

### T36

#### Write the names, listen and colour

The sun is the biggest and the hottest star.  
It is the colour of fire: orange and red with some black spots.

The Earth is bigger than the moon.  
It is a planet.  
It is blue and green.  
The blue is the water and the green is the land.

The moon is the smallest.  
It is a satellite.  
It is white and blue with some black marks.

### T37

#### Listen, match, write the words

The sun is a star.  
It is the biggest and the hottest.  
The Earth is a planet.  
It moves around the sun in one year.  
The moon is a satellite.  
It moves around the Earth.

## Reversible and irreversible changes

### T35

#### Reversible and irreversible changes

Materials can be changed by being heated, cooled, burned, mixed or dissolved.

Mixtures can be sieved or filtered. Solutions can be evaporated and condensed to separate the substances. These are reversible changes.

Sometimes new materials are made that cannot be changed back – these are *irreversible* changes.

## Seasons

### T38

#### Chant: Spring, summer, autumn, winter

Spring, summer, autumn, winter,  
We can say them fast.  
Spring, summer, autumn, winter,  
Now it's fun at last.

Spring is warm,  
Summer's hot,  
Autumn's cool,  
Winter is so cold we always wear a lot.  
Summer, autumn, winter, spring –  
Say them fast and show that we can sing!

Spring, summer, autumn, winter –  
The seasons come and go.  
Spring, summer, autumn, winter,  
They change from sun to snow.

Spring, summer, autumn, winter,  
We can say them fast.  
Spring, summer, autumn, winter,  
Now it's fun at last.

**What do we wear in winter?****T39****Song: This is the way we put on our clothes**

This is the way we put on our clothes, put on our clothes,  
put on our clothes,

This is the way we put on our clothes on a Sunday  
morning.

This is the way we put on our coat, put on our coat,  
put on our coat,

This is the way we put on our coat on a Monday  
morning.

This is the way we put on our jumper, put on our jumper,  
put on our jumper,

This is the way we put on our jumper on a Tuesday  
morning.

This is the way we put on our shirt, put on our shirt,  
put on our shirt,

This is the way we put on our shirt on a Wednesday  
morning.

This is the way we put on our shorts, put on our shorts,  
put on our shorts,

This is the way we put on our shorts on a Thursday  
morning.

This is the way we put on our socks, put on our socks,  
put on our socks,

This is the way we put on our socks on a Friday morning.

This is the way we put on our shoes, put on our shoes,  
put on our shoes,

This is the way we put on our shoes on a Saturday  
morning.

**Moving toys: pushes and pulls****T40****Song: Push, push, push the cart**

Push, push, push the cart  
Slowly up the road.

Pull, pull, pull from in front,  
What a heavy load!

Push, push, push with your foot  
To make the scooter go.

Brake, brake, brake with your foot  
To make the scooter slow.

**Pushing, pulling and slopes****T41****Listen, look and number**

- 1 The boys are pushing the go-kart up the hill.
- 2 The woman is pulling the door open.
- 3 The children are pushing the cart down the hill.
- 4 The donkey is pulling the cart up the hill.
- 5 The girl is pushing the baby on the swing.
- 6 The mother is pushing the pram up the hill.
- 7 The man is pushing the cart up the hill.
- 8 The girl is pushing the car up the hill.
- 9 The boy is pushing the scooter with his foot.
- 10 The boy is pulling the go-kart.

**Friction and movement****T42****Song: Friction on the bus**

The wheels on the bus go round and round,  
Round and round, round and round,  
But friction's there to slow them down:  
Wheels grip the road!

**T43****Friction slows things down**

Tom goes down the slide. He goes fast.

Anna goes down the slide. She wants to go faster than  
Tom but she goes more slowly.

Anna takes off her big boots. Now she goes as fast  
as Tom.

**Working with magnets****T44**

Magnets can attract or pull things towards them.  
Some magnets are stronger than others.

**T45**

Magnetism is a force; it pulls or pushes magnetic  
materials.

A magnet attracts anything made of iron and steel.  
There is a magnetic field round a magnet.

## T46

### Fact box

Magnetism is a force.

Magnets are surrounded by a magnetic field.

The opposite ends of a magnet are called poles.

Opposite poles attract. Like poles repel.

Magnets attract anything made of iron, for example, steel.

Magnets also attract alloys of nickel and cobalt.

## Unit 8

### Lesson 2a

## Reflections

### T50

#### Chant: Mirror image

I look in the mirror,

What do I see?

I see my two eyes

Looking at me!

I wave my right hand,

What do I see?

I see my left hand

Waving at me!

I look in the mirror,

What do I see?

A reversed image

Looking at me!

## Unit 8

### Lesson 1a

## Light sources

### T47

Candle

Torch

Moon

Stars

Cat's eyes

Match

Light bulb

Fire

Sun

Mirror

Lamp

Television

### T48

#### Song: Light

Bright light,

Dim light.

Sun in the morning,

Moon at night.

Stars that twinkle,

A fire that glows.

My torch is shining

Then out it goes!

## Unit 8

### Lesson 2b

## Everyday sounds and volume

### T51

#### Warm up

*[Sound effects only – no words]*

bang

hiss

squeak

indistinct whispering

pop

### T52

#### Chant: What is sound?

What is sound?

It's shaking air.

It's vibrating

Everywhere.

It's not just

the air that shakes.

Sound can go through

Hills and lakes.

What is volume?

Loud or soft?

You'll have to shout,

I'm in the loft!

What is pitch?

It's high or low.

Vibrations fast,

Vibrations slow.

Sound vibrations

I can hear,

All end up

Inside my ear!

## Unit 8

### Lesson 1b

## Light and shadows

### T49

#### Poem: Shadows

Shadows big,

Shadows small.

See the shadows on the wall!

Shadows tall,

Shadows wide.

Shadows make me want to hide!

That's my shadow.

Now I see, that my shadow's

Joined to me!

## T53

### Rap: Noisy day rap

Snap your fingers,  
Hiss like a snake.  
Don't *bang* the drum –  
Baby will wake!

Rattle baby's rattle,  
Squeak like a mouse.  
I hear *footsteps*  
Outside the house!

Please don't *whisper*,  
You'll have to *shout*.  
It's very noisy,  
School is out!

Crackle crisp packets,  
Pop the balloon.  
Ref. blows the *whistle*,  
Football starts soon.

## Unit 8

### Lesson 3a

### Light review

## T54

### Song: Can you see through it?

Transparent, transparent –  
You can see through it.  
Translucent, translucent –  
You can see a bit.  
Opaque, opaque –  
That's much too thick.  
Opaque, opaque –  
Can't see through a brick!

## T55

### Scientific words and dictionary definitions

Eye. We use this to see.  
See. We do this with our eyes.  
Light. Opposite of dark.  
Sight. Sense using eyes.  
Lens. In eyes, cameras, telescopes.  
Shadow. There is not much light here.  
Image. Seen in a mirror.  
Transparent. Light goes through this.  
Translucent. Some light goes through this.  
Opaque. No light goes through this.  
Reflection. The image in a mirror.  
Refraction. Bending light.

## Unit 8

### Lesson 3b

### Sound: Pitch

## T56

### Pitch

[Sound effects only – no words]: Two very different pitches – one high, one low, followed by 5 or 6 more sounds of very different pitches]

## Unit 9

### Lesson 1a

### Save – don't waste!

## T57

### Song: Save, save, save!

Saving water,  
Saving water.  
Turn off the tap,  
Turn off the tap.  
Never leave it dripping,  
Never leaving it dripping.  
Splish, splash, splat,  
Splish, splash, splat!

Save electricity,  
Save electricity.  
Switch off the light,  
Switch off the light.  
Turn off the computer,  
Turn off the computer  
For the night,  
For the night!

Saving petrol,  
Saving petrol.  
Sharing cars,  
Sharing cars.  
Catch a bus or cycle,  
Catch a bus or cycle.  
Walk, walk, walk,  
Walk, walk, walk!

## Recycling

## T58

**Song: We'll be recycling when we can**

We'll be recycling paper when we can.  
 We'll be recycling glass when we can.  
 We'll be recycling plastic,  
 Recycling metal,  
 Recycling everything we can.

## T59

**Recycling race track**

A. Start.  
 Collect plastic bottles for recycling.  
 Take glass bottles to bottle bank.  
 Recycle newspapers.  
 Throw drink can in litter bin.  
 Recycle drink can.  
 Throw comic in rubbish bag.  
 Start. B.  
 Leave plastic drink bottle in playground: -4 points.  
 Use old envelopes for shopping lists: +2 points.  
 Throw glass jar in rubbish bag.  
 Give comic to a friend: +2 points.  
 Recycle jam jars.  
 Give away old toys: +2 points.  
 1 point.  
 2 points.  
 0 points.

## Personal communication links

## T60

**Song: Send a letter**

Send a card, a text,  
 An email or a letter,  
 Or a note to say  
 'I hope you're feeling better!'

I have attached  
 Something to make you laugh.  
 Click and you'll see  
 A silly photograph!

Send a card, a text,  
 An email or a letter,  
 Or a note to say  
 'I hope you're feeling better!'

## T61

**Thinking of you**

*Child 1:* How can I send the present I made to my Granny in Australia?

*Narrator:* A.

*Child 2:* I want to talk to my friend who has gone to live in America.

*Narrator:* B.

*Child 3:* We need to tell Mum something but she is at work and cannot talk.

*Narrator:* C.

*Child 4:* My Dad is working in England. I want to send him the card I made.

*Narrator:* D.

*Child 5:* How can I show this photo to my Granddad? He lives a long way from here.

*Narrator:* E.

*Child 6:* I have written a story. I want all my friends to read it.

*Narrator:* F.

*Child 7:* How can I hear your news when I don't know where you are?

*Narrator:* G.

*Child 8:* There has been an accident. I need to call an ambulance.

*Narrator:* H.

## Global communications

## T62

**Match the words to the pictures.**

*Young person:* Hi, Mum. You can see the volcano erupting now.

*Newspaper voice:* The volcano began to erupt early yesterday morning. This photo, taken on a mobile phone by an eye witness, shows ...

*TV newsreader:* The volcano began to erupt at about six o'clock this morning.

*Radio newsreader:* This is the seven o'clock news. Here is our reporter who is at the scene.

*Blog voice:* The Government should have warned us that the volcano was going to erupt.

## T63

**Something to talk about!**

How do we know what is happening in our town?  
 How do we know what is happening in our country?  
 How do we know what is happening in our world?  
 How do we know these things are true?  
 Can we trust the reporters?

**Carbon footprint****T64****My carbon footprint**

Choices:

- ... not waste water.
- ... paint my feet green!
- ... turn down the heating and put on a jumper.
- ... walk when I can.
- ... not waste paper.
- ... share a lift when I can.
- ... eat 10 ice creams every day!
- ... cycle when I can.
- ... eat food grown near home.
- ... turn down the cooler and take off a jumper.
- ... not leave the computer on standby.
- ... plant a tree.

**Helping the Earth****T65****Bingo game**

One – RECYCLE

Three – ONE COMPUTER SWITCHED ON 24/7 EMITS  
600 KG CO<sub>2</sub> IN A YEAR – SWITCH OFF

Five – A DRIPPING TAP CAN WASTE 90 LITRES OF WATER  
A DAY – TURN IT OFF

Seven – DON'T WASTE PAPER

Nine – NEVER LEAVE LITTER

Eleven – USE ENERGY SAVING LIGHT BULBS

Thirteen – 50% OF RAINFORESTS HAVE BEEN CUT DOWN  
SINCE 1950 – PLANT A TREE

Fifteen – SIT IN A TRAFFIC JAM

Seventeen – SAY NO TO DRUGS

Nineteen – WALK

**The water cycle****T66****Poem: The water cycle**

The sun is shining on the Earth;  
Heats the water for all it's worth.  
Evaporation won't take long;  
Now it's vapour; water's gone.  
Vapour's moving, will not stop;  
Clouds are forming, drop by drop.  
No more vapour, give a cheer!  
Condensation – water's here.  
Now it's raining, cold and snow,  
Lakes and rivers rise and flow.  
See the water moving fast,  
Running to the sea at last.

**What's the weather like?****T67****Chant: The weather**

One day the sun was shining bright  
But clouds came along; it was dark as night.  
The rain began to sprinkle down.  
Soon it was raining all over town.  
But when the clouds had passed on by,  
A beautiful rainbow stretched across the sky.

**T68****Read a weather map**

Good morning. Today we have the weather forecast for  
the British Isles.

In Scotland, in Edinburgh, it is cold with snow and ice.

In England, in London, it is sunny but windy and cool.

In Wales, in Cardiff, it is cloudy and foggy.

In Ireland, in Belfast and Dublin, there are storms with  
thunder, lightning and rain.

**The importance of water****T69****Chant: We need water**

We need water to wash in, water for play,  
Water for washing things every day.  
Water to grow things to keep us alive,  
Water to drink so that we can survive.

Water in bottles, water in pans,

Water in kettles, water in cans.

It's always the shape of whatever it's in –

Bucket or kettle, or bottle or tin.

[Repeat]